

# TECHNICAL REFERENCE

– Realtime Express (RTEX) Communication Specification –

---

MODEL

Product Name: AC Servo Driver

Part Number: MINAS-A5N Series (RTEX communication type)

---

Issued on  
May. 31<sup>th</sup>, 2011

Revised on  
Mar. 30<sup>th</sup>, 2012

Motor Business Unit, Appliances Company  
Panasonic Corporation

7-1-1 Morofuku, Daito-City, Osaka 574-0044, Japan  
Phone : (072) 871-1212  
Fax : (072) 870-3151

この英文仕様書は、原本である和文仕様書を元にパナソニック株式会社ホームアプライアンス社モータビジネスユニットが翻訳・発行するものです。翻訳は、原本の利用に際して一応の参考となるように便宜的に仮訳したものであり、公的な校閲を受けたものではありません。英語訳のみを使用して生じた不都合な事態に関しては、当社は一切責任を負うものではありません。和文仕様書のみが有効です。

パナソニック株式会社  
アプライアンス社 モータビジネスユニット

This English specification is made and published by Motor Business Unit Home Appliances Company of Panasonic Corporation based on the original Japanese specification. Translation is provided unofficially only for the sake of convenience of utilizing the original Japanese specification as a measure of reference. It is not officially reviewed. Motor Business Unit Home Appliances Company of Panasonic Corporation is not liable for any disadvantages caused by utilizing only English specification. Only the Japanese specification is effective.

Motor Business Unit, Appliances Company,  
Panasonic Corporation

# Revisions

Date	Page	Rev.	Description	Signed
May. 31, 2011		1.0	NEWLY ISSUED	-
Nov. 14, 2011	1	2.0	Software upgrade Ver1.00 -> Ver1.01	-
	1		The table of changes is added.	
			1) Function addition "External scale position information monitoring facility at the semi-closed control"	
	6		-Added the description of Notes *	
	54		-Added the description of Notes *2)	
	84		-Added the description in Type_Code of 0Dh	
			2) Function addition "Parameter attribute read-out function, The number read-out function of the parameters in a classification"	
	70		-Added the description of the explanation of command and response	
	71		-Added the description in Type_Code of 030h	
	72		-Added the description in Type_Code of 040h	
	73		-Added the description in the Section 6-7-3	
	74		-Added the description of example and response table	
			3) Function addition "RTEX_update_counter error protection feature"	
	143		-Added the description of Err86.2	
	151		-Added the description in the Section 8-1-8	
			4) Function addition "Torque saturation protection function"	
			(* This data has no change, and no addition)	
			5) Function addition "The falling edge detection function of a latch trigger"	
	58		-Added the description in Type_Code of 13h,15h,17h,19h,1Bh,1Dh	
	58		-Added the description of Notes *3)	
	63,78		-Changed the table of Latch_Set	
	102		-Added the description of contents of falling edge	
			6) Function addition "The function which displays MACID on front LED to communication establishment"	
			(* This data has no change, and no addition)	
			7) Function addition "USB connection check function"	
			(* This data has no change, and no addition)	
			8) Function addition "For manufacturer's use function"	
	54		-Added the description in Type_Code of 06h	
	6		Changed the description of "Network status LED"	
	7		Added the description of Note (about a communication cycle setup)	

Note: The page number (Page) is the current page number at the time of revision.

# Revisions

Date	Page	Rev.	Description	Signed
Nov. 14, 2011			(Continuation)	-
	7,25		Added the description in Function/Contents of Pr7.22(bit2-4)	
	79		Added the description of In_Position	
	81		Changed the description of Parameter name (Pr7.11,Pr7.12)	
	81		Correction Inside of explanation of NSL Pr7.11->Pr7.12	
	82		Added the description of a profile command	
	66-68,71,72		Added the description of Command_Data3(Setting_Data)	
	49,50,53,57,65,70,83		Added the description of Command_Data3(Setting_Data)	
	55		Correction the description in Type_Code_Echo of 010h->01h	
	74		Correction the description of "RTEX communication reset command."	
	96,153		Added the description of various "causes"	
	139		Correction the description of Pr7.32->Pr7.35	
	139		Correction the description of Pr7.35="0" column.	
	139		Correction the description of Command_Data3 at the time of FF invalidity are corrected.	
Mar.30,2012	All	2.1	Changed company name.	-
	34		Correction the description of Response_Data1/2/3	
	129,130,131,133		Changed the description of Profile homing	

Note: The page number (Page) is the current page number at the time of revision.

Contents
----------

1. Introduction .....	1
2. Configuration and Initialization of RTEX Communication System.....	2
2-1 Outline.....	2
2-2 System structure .....	2
2-3 Basic specifications of network.....	3
2-4 Node address (MAC-ID) setting and front panel configuration .....	4
2-5 Communication cycle/command updating cycle, control mode and data size setup.....	5
2-5-1 Mode reference table [Under review].....	6
2-5-2 Related Parameter .....	7
2-5-3 Example of mode setup .....	7
2-6 COM LED, LINK LED and RTEX communication state .....	8
3. Transmission Protocol of RTEX Communication Data .....	9
3-1 Transmission timing of data .....	9
3-1-1 Transmission timing of communication period 0.5 ms/command updating period 0.5 ms.....	10
3-1-2 Transmission timing of communication cycle 0.5 ms/command updating cycle 1.0 ms .....	10
3-1-3 Transmission timing of communication cycle 0.1666 ms/command updating cycle 0.1666 ms .....	11
3-1-4 Transmission timing of communication cycle 0.0833 ms/command updating cycle 0.1666 ms .....	11
3-1-5 Transmission timing of communication cycle 1.0 ms/command updating cycle 1.0 ms .....	12
3-2 Transmission of cyclic data .....	13
3-2-1 Cyclic transmission area.....	13
3-3 Transmission of Non-Cyclic Data .....	14
3-3-1 Non-cyclic transmission area.....	14
3-3-2 Non-cyclic status flag.....	15
3-3-3 Non-cyclic command startup mode setting .....	16
3-3-4 Startup of non-cyclic command (MINAS-A4N compatible mode).....	17
3-3-4-1 Basic sequence of non-cyclic command .....	18
3-3-4-2 Read sequence of non-cyclic command.....	19
3-3-4-3 Write sequence of non-cyclic command .....	20
3-3-5 Startup of non-cyclic command (extend mode).....	21
4. RTEX Communication Data Block .....	22
4-1 Transmission and reception memory in MNM1221 .....	22
4-2 Command data block arrangement (16-byte/32-byte mode) .....	23
4-2-1 Command code and command argument (Command bytes 1, 4–15).....	24
4-2-1-1 TMG_CNT setup and inter-axis synchronous mode .....	25
4-2-2 Command header (command byte 0).....	27
4-2-2-1 Update_Counter setup.....	27
4-2-3 Control bit (Command Bytes 2 and 3).....	28
4-2-3-1 Servo_On/off command (Servo_on).....	29
4-2-3-2 Gain switching command (Gain_SW) .....	30
4-2-3-3 Torque limit switching command (TL_SW) .....	31
4-2-3-4 Speed limit switching command (SL_SW).....	31
4-2-3-5 External output signal operation instruction (EX-OUT 1/2).....	32

4-3 Data block in response (16-byte/32-byte).....	33
4-3-1 Command_Code_Echo and Response_Data (Response byte 1, 4 to 15).....	34
4-3-2 Response header (Response byte 0) .....	34
4-3-3 Status flag (Response byte 2) .....	35
4-3-3-1 Servo Ready state (Servo_Ready).....	36
4-3-3-2 Internal position command generation state (In_Progress)/main power off alarm state (AC_OFF).....	36
4-3-4 Input signal status flag (Response byte 3) .....	37
4-4 Command data block of sub-command (only for 32-byte mode).....	38
4-4-1 Sub-command code and sub-command argument (Command bytes 16 to 31).....	39
4-5 Response data block of sub-command (only for 32-byte mode) .....	40
4-5-1 Sub-command code echo and response data (Command bytes 16 to 31) .....	41
5. Cyclic Command Description .....	42
5-1 Cyclic command list [Under review].....	42
5-2 NOP command (Command code: 0□h).....	43
5-3 Profile position control (PP) command (Command code: 1□h [Under review] .....	44
5-4 Cyclic position control (CP) command (Command code: 2□h).....	45
5-5 Cyclic velocity control (CV) command (Command code: 3□h) .....	46
5-6 Cyclic torque control (CT) command (Command code: 4□h) .....	47
6. Non-cyclic Command Description .....	48
6-1 Non-cyclic command list [Under review] .....	48
6-2 Normal command (Command code: □0h).....	49
6-3 Reset Command (Command code: □1h) .....	50
6-3-1 Software reset mode (Type_Code: 001h).....	51
6-3-2 Attribute C parameter validation mode (Type_Code: 011h).....	52
6-4 System ID Command (Command code: □2h) .....	53
6-4-1 System ID command Type_Code list .....	54
6-4-2 Example of reading of vendor name (“Panasonic”).....	55
6-4-3 Device type.....	55
6-4-4 Servo driver type.....	56
6-5 Homing command (Command code: □4h).....	57
6-5-1 Type Code list of Homing Command .....	58
6-5-2 Assignment of external input signals related to return to home sequence .....	60
6-5-3 Actual position setup and command position setup .....	61
6-5-4 Latch mode.....	63
6-5-4-1 Starting/canceling latch mode.....	63
6-5-4-2 Selecting latch trigger signal.....	63
6-5-4-3 Checking latch mode complete status and latch position data .....	64
6-6 Alarm command (Command code: □5h).....	65
6-6-1 Alarm command Type_Code list .....	66
6-6-2 Setting up of alarm code.....	69
6-6-3 Alarm attribute.....	69
6-7 Parameter Command (Command code: □6h) .....	70
6-7-1 Type code list of parameter command.....	71
6-7-2 Parameter number of MINAS-A5N series.....	72
6-7-3 Parameter attribute of MINAS-A5N series .....	74
6-7-4 Protecting parameter writing/EEPROM writing through RTEXX .....	74

6-8 Profile command (Command code: 17h).....	75
6-8-1 Profile command Type_Code list .....	77
6-8-2 Selection of latch trigger signal for positioning profile position latch.....	78
6-8-3 Checking latch mode complete status and latch position data.....	78
6-8-4 Stop command.....	79
6-8-5 Profile positioning neighborhood output (NEAR).....	80
6-8-6 Software limit (PSL/NSL).....	81
6-8-7 Other precautions related to profile command.....	82
6-9 Monitor Command (Command Code: □Ah).....	83
6-9-1 Type code list of monitor command [Under review].....	84
6-9-2 Cause of no revolution .....	87
6-9-3 Assignment of the warning flag.....	88
6-9-4 Position information during servo off, velocity control and torque control.....	88
6-9-5 Status of input and output signals.....	89
6-10 Command error (Command code: □□h).....	92
6-10-1 Command error detection.....	93
6-10-1-1 Command error common to 16-byte and 32-byte modes.....	93
6-10-1-2 Command error in 32-byte mode.....	95
6-10-2 List of command error code .....	96
6-11 Communication Error (Command code: □□h/ Response code: FFh).....	97
7. Operation.....	98
7-1 Cyclic position control (CP) operation.....	98
7-1-1 Command follow-up process (command position at servo-off).....	98
7-1-2 Prohibited matter of NOP command (0□h) .....	99
7-1-3 Command position upon communication error .....	99
7-1-4 Variations in command position during command updating period.....	100
7-1-4-1 Limiting variations in command position .....	100
7-1-4-2 Wrap rounding command position.....	100
7-1-4-3 Clearing position deviations .....	100
7-2 Homing operation.....	101
7-2-1 Normal return-to-home sequence in cyclic position control (CP) mode.....	102
7-2-2 Sequence of actual position/command position setup .....	103
7-2-3 Example of cyclic homing operation.....	105
7-2-3-1 Example of cyclic homing operation 1 .....	106
7-2-3-2 Example of cyclic homing operation 2 .....	108
7-2-3-3 Example of cyclic homing operation 3 .....	109
7-2-3-4 Example of cyclic homing operation 4 .....	110
7-2-4 Initialization of the absolute encoder.....	111
7-2-4-1 Absolute data .....	111
7-2-4-2 Clearing multi-turn data.....	112
7-3 Cyclic velocity control (CV) operation .....	113
7-4 Cyclic torque control (CT) operation [Under review].....	115
7-5 Profile position control (PP) operation.....	117
7-5-1 Profile position control (PP) related parameter .....	117
7-5-2 Profile absolute positioning (Type_Code: 10h).....	118
7-5-3 Profile relative positioning (Type_Code: 11h).....	120

7-5-4 Profile position latch absolute positioning (Type_Code: 12h).....	122
7-5-5 Profile position latch relative positioning (Type_Code: 13h).....	125
7-5-6 Profile continuous revolution (JOG) (Type_Code: 20h).....	126
7-5-7 Profile homing 1 (HOME + Z phase) (Type_Code: 31h).....	128
7-5-8 Profile homing 2 (HOME + Z phase) (Type_Code: 32h).....	130
7-5-9 Profile homing 3 (Z phase) [Type_Code: 33h].....	132
7-5-10. Precautions for profile position control operation.....	134
7-6 Control mode switching.....	136
7-6-1 Control mode switching method.....	136
7-6-2 Precautions for control mode change during operation.....	137
7-6-3 Other precautions related to control mode switching.....	138
7-7 Feedforward function.....	139
7-7-1 Feedforward function validation parameter and command area to be used.....	139
7-7-2 Setting unit and setting range.....	141
7-7-3 Compatible control mode.....	141
7-7-4 Other precautions related to feedforward function.....	142
<b>8. RTEX Communication Related Protective Function and Troubleshooting.....</b>	<b>143</b>
8-1 RTEX communication related protective function.....	143
8-1-1 RTEX node address setting error protection (Err. 82.0).....	144
8-1-2 RTEX continuous communication error protection 1 (Err. 83.0).....	145
8-1-3 RTEX continuous communication error protection 2 (Err. 83.1).....	146
8-1-4 RTEX time out error protection (Err. 84.0).....	147
8-1-5 RTEX synchronization and initialization error protection (Err. 84.3).....	148
8-1-6 RTEX communication cycle error protection (Err. 84.5).....	149
8-1-7 RTEX cyclic data error protection 1/2 (Err. 86.0/Err. 86.1).....	150
8-1-8 RTEX interaxis sync establishment error protection (Err90.2).....	152
8-1-9 RTEX command error protection (Err91.1).....	153
8-1-10 RTEX hardware error protection 1/2/3 (Err. 98.1/Err. 98.2/Err. 98.3).....	154
8-2 RTEX communication warnings.....	155
8-2-1 RTEX continuous communication error warning (WngC0h).....	155
8-2-2 RTEX accumulated communication error warning (WngC1h).....	156
8-2-3 RTEX Update_Counter error warning (WngC2h).....	157
8-3 Locating disconnection point of network cable.....	158



## 1. Introduction

This technical reference describes the specifications of the network interface “Realtime Express” (hereafter referred to as RTEX) which connects the driver MINAS-A5N series to the host controller. This document should be treated according to the nondisclosure contract.

### <Software version>

This technical reference applies to the servo drivers compatible with software of the following version:

Ver.1.01 or later

\*Please check the software version by setup support software PANATERM.

Ver1.00	First edition																			
Ver1.01	<table border="1"> <thead> <tr> <th>Additional capability</th> <th>Reference</th> </tr> </thead> <tbody> <tr> <td>1) External scale position information monitoring facility at the semi-closed control</td> <td>This document 6-4-1 , 6-9-1 SX-DSV02202 4-8 , 7-2 , 9-1</td> </tr> <tr> <td>2) Parameter attribute read-out function The number read-out function of the parameters in a classification</td> <td>This document 6-7 , 6-7-3 , 6-7-4</td> </tr> <tr> <td>3) RTEX_update_counter error protection feature</td> <td>This document 8-1 , 8-1-8 SX-DSV02202 7-1 , 7-2 , 9-1</td> </tr> <tr> <td>4) Torque saturation protection function</td> <td>SX-DSV02202 6-4 , 7-1 , 7-2 , 9-1</td> </tr> <tr> <td>5) The falling edge detection function of a latch trigger</td> <td>This document 6-5-1 , 6-5-4-2 , 6-8-2 , 7-2-1 , 7-5-4</td> </tr> <tr> <td>6) The function which displays MACID on front LED to communication establishment</td> <td>SX-DSV02202 3-2 , 9-1</td> </tr> <tr> <td>7) USB connection check function</td> <td>PANATERM Operation manual</td> </tr> <tr> <td>8) For manufacturer’s use function</td> <td>This document 6-4-1 SX-DSV02202 9-1</td> </tr> </tbody> </table>		Additional capability	Reference	1) External scale position information monitoring facility at the semi-closed control	This document 6-4-1 , 6-9-1 SX-DSV02202 4-8 , 7-2 , 9-1	2) Parameter attribute read-out function The number read-out function of the parameters in a classification	This document 6-7 , 6-7-3 , 6-7-4	3) RTEX_update_counter error protection feature	This document 8-1 , 8-1-8 SX-DSV02202 7-1 , 7-2 , 9-1	4) Torque saturation protection function	SX-DSV02202 6-4 , 7-1 , 7-2 , 9-1	5) The falling edge detection function of a latch trigger	This document 6-5-1 , 6-5-4-2 , 6-8-2 , 7-2-1 , 7-5-4	6) The function which displays MACID on front LED to communication establishment	SX-DSV02202 3-2 , 9-1	7) USB connection check function	PANATERM Operation manual	8) For manufacturer’s use function	This document 6-4-1 SX-DSV02202 9-1
	Additional capability	Reference																		
	1) External scale position information monitoring facility at the semi-closed control	This document 6-4-1 , 6-9-1 SX-DSV02202 4-8 , 7-2 , 9-1																		
	2) Parameter attribute read-out function The number read-out function of the parameters in a classification	This document 6-7 , 6-7-3 , 6-7-4																		
	3) RTEX_update_counter error protection feature	This document 8-1 , 8-1-8 SX-DSV02202 7-1 , 7-2 , 9-1																		
	4) Torque saturation protection function	SX-DSV02202 6-4 , 7-1 , 7-2 , 9-1																		
	5) The falling edge detection function of a latch trigger	This document 6-5-1 , 6-5-4-2 , 6-8-2 , 7-2-1 , 7-5-4																		
	6) The function which displays MACID on front LED to communication establishment	SX-DSV02202 3-2 , 9-1																		
	7) USB connection check function	PANATERM Operation manual																		
8) For manufacturer’s use function	This document 6-4-1 SX-DSV02202 9-1																			

\*Ver1.01 becomes the upper compatible of Ver1.00.

The parameter used by Ver1.00 can be used by Ver1.01 as it is.

\*The version of PANATERM corresponding to Ver1.01 is 5.0.1.8 or later.

### <Object person>

This document is intended for use by engineers who design a host system that controls the servo driver MINAS-A5N series.

### <References>

SX-DSV02201: Reference specification (mainly describes specifications related to hardware)

SX-DSV02202: Technical reference (functional specification)

### <IMPORTANT>

- All rights reserved. No part of this publication may be reproduced or transmitted in any form without prior permission .
- Motor Business Unit, Home Appliances Company Panasonic Corp. reserves the right to make modifications and improvements to its products and/or documentation, including specifications and software, without prior notice.

## 2. Configuration and Initialization of RTEX Communication System

### 2-1 Outline

MINAS-A5N Series equips the communication ASIC “MNM1221” which can be functioned in combination with 100BASE-TX PHY (physical layer chip) conforming to IEEE 802.3.

You can compose 100 Mbps real-time communication system of Master-Slave method that suits to multi-axes servo control, by ring-connecting the slave (MINAS-A5N series etc.) with the master (host controller) equipped with the same MNM1221.

MNM1221: Option No. DV0P444

### 2-2 System structure

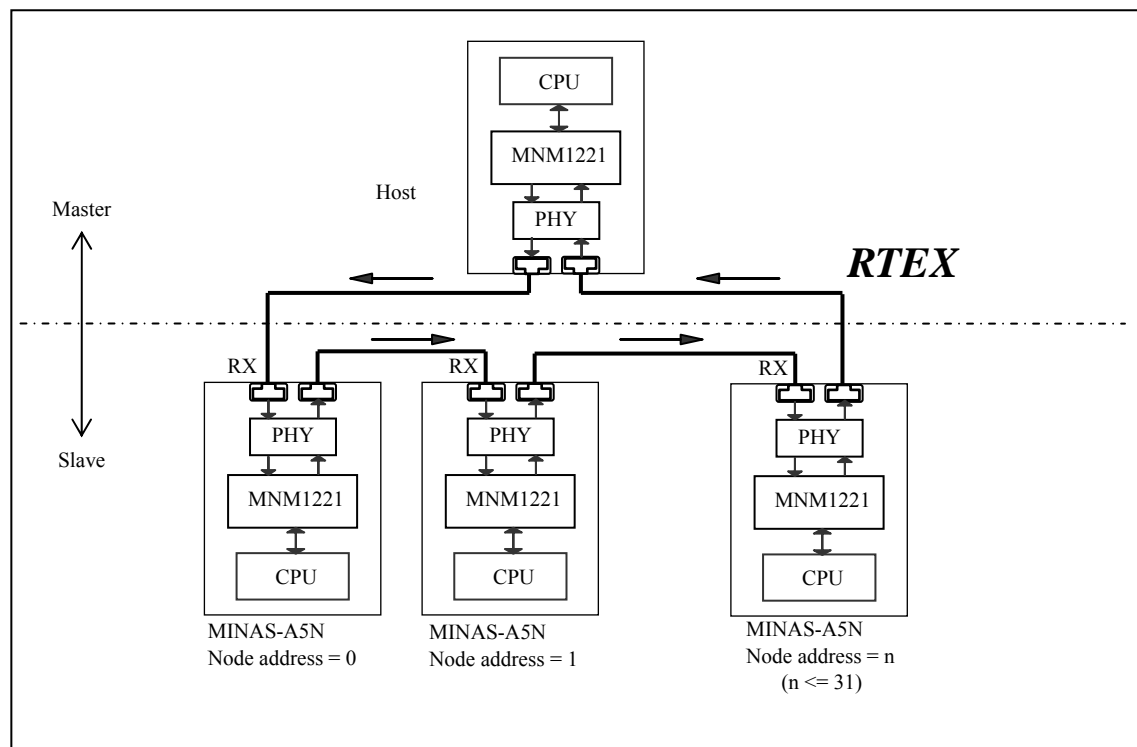

Node address is the ID (MAC-ID) used to identify the slave on the network, and set up with the rotary switch (RSW) on the front panel.

For the master produced by using the sample code provided by us, the node address setting procedure shown in the figure above will not be required.

#### Notes:

- A Hub required in standard 100BASE-TX is not used because of ring topology.
- In the above figure, pulse transformer which is connected between PHY and connector and other components are omitted.
- Use the STP (shield twisted pair) cable of Category-5e or upper specified by TIA/EIA-568 Standards for the communication cable.

## 2-3 Basic specifications of network

The following describes the basic specifications of the network interface.

Item	Specifications
Topology	Ring
Physical layer	100BASE-TX (IEEE 802.3)
Baud rate	100 [Mbps]
Network Status LED	[COM], [LINK] 2 units
Setup of node address (MAC-ID)	Rotary switch (2-digit) on the front panel Setup range: 0 to 31 (Default 0)
Communication cycle (physical data transfer cycle)	0.0833, 0.1666, 0.5, 1 [ms]
Command update period	0.1666, 0.5, 1 [ms]
Control mode	PP: Profile position mode CP: Cyclic position mode CV: Cyclic velocity mode CT: Cyclic torque mode
Connecting cable	STP (shield twisted pair) cable conforming to category 5e or more of TIA/EIA-568 standards. Note: Use the straight wiring.
Cable length	a) Inter nodes: Max. 100 [m] [Under review] b) Total: Max. 200 [m] [Under review] Note: Use within the range which satisfied both of the above conditions. Consult with us when you use exceeding the above b) condition.
Slaves to be connected (axes)	Max. 5 when communication cycle time is 0.0833 ms Max. 10 when communication cycle time is 0.1666 ms Max. 32 when communication cycle time is 0.5, 1.0 or 1.0 ms Notes: <ul style="list-style-type: none"> <li>Number of axes when all connected axes are in 16-byte mode. When in the 32-byte mode, the number of axes connected is one half that of axes connected in the 16-byte mode because the number of transmit-receive data blocks is twice that required in the 16-byte mode (fractions omitted).</li> <li>These figures depend on the arithmetic processing power of the host device.</li> </ul>
Data size	16-byte mode: Transmit/receive 32-byte mode: Transmit/receive
Communication error detection	CRC-CCITT

## 2-4 Node address (MAC-ID) setting and front panel configuration

The figure below shows the front panel configuration of MINAS-A5N series.

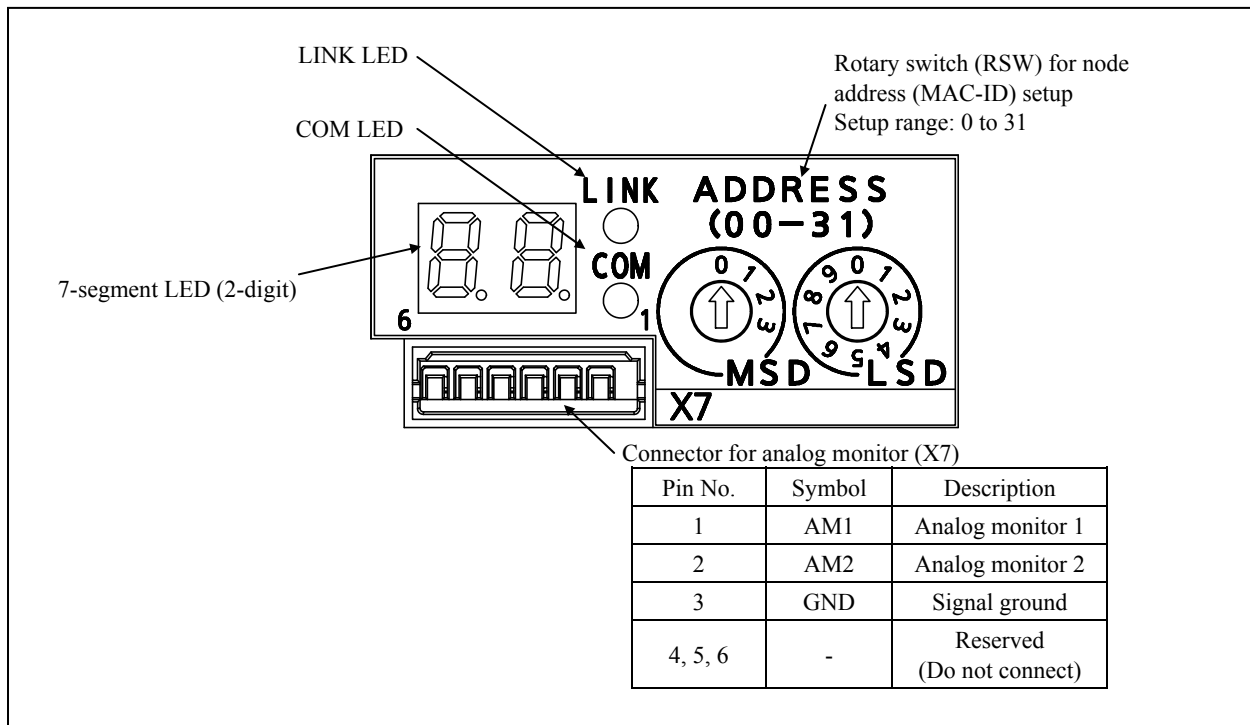

- Set the node address (MAC-ID) in a decimal number: high order digit on MSD rotary switch and low order on LSD switch.  
Example: When MAC-ID is 13, MSD = 1, LSD = 3.
- Node address (MAC-ID) set with the rotary switch will be loaded once when the control power is turned on. Therefore, a change made after the power up will not be reflected to the control but will become active upon the next power up.
- Do not change the value of the rotary switch in power on to avoid a trouble.
- Setup range of the node address (MAC-ID) is 0 to 31.  
If the setup value exceeds 31, Err 82.0 (COM invalid node-address protection) will be occurred.
- The host controller (master), when transmitting, should specify the node address (MAC-ID) in Byte 0, bits 4-0 of the command. If the node address is different from the address specified by the servo drive, Err 86.0 Cyclic data error protection 1 will occur.

## 2-5 Communication cycle/command updating cycle, control mode and data size setup

Designation	Description							
Communication cycle	<ul style="list-style-type: none"> <li>The cycle at which command or response RTEX frame is transferred.</li> <li>The servo driver processes the command and response basically at this cycle.</li> </ul>							
Command updating cycle	<ul style="list-style-type: none"> <li>The cycle at which the host controller will update the command.</li> <li>In response, the servo driver performs the following processes. <table border="1"> <tr> <td>Communication cycle 0.0833 ms</td> <td> <ul style="list-style-type: none"> <li>Processes the command and response with a period of 0.1666 ms.</li> <li>Set the command updating cycle to 0.1666 ms.</li> </ul> </td> </tr> <tr> <td rowspan="2">Other communication cycles</td> <td>CP</td> <td> <ul style="list-style-type: none"> <li>Calculates the changes in command position (CPOS) during command updating period and generates the movement command.</li> <li>If the command updating cycle on the servo driver is different from that on the host controller, operation error will occur.</li> <li>Processes commands and responses at a position other than the command position during communication cycle.</li> </ul> </td> </tr> <tr> <td>PP/CV/CT</td> <td> <ul style="list-style-type: none"> <li>Processes commands and responses at the communication cycle, regardless of the command updating cycle.</li> </ul> </td> </tr> </table> </li> </ul>	Communication cycle 0.0833 ms	<ul style="list-style-type: none"> <li>Processes the command and response with a period of 0.1666 ms.</li> <li>Set the command updating cycle to 0.1666 ms.</li> </ul>	Other communication cycles	CP	<ul style="list-style-type: none"> <li>Calculates the changes in command position (CPOS) during command updating period and generates the movement command.</li> <li>If the command updating cycle on the servo driver is different from that on the host controller, operation error will occur.</li> <li>Processes commands and responses at a position other than the command position during communication cycle.</li> </ul>	PP/CV/CT	<ul style="list-style-type: none"> <li>Processes commands and responses at the communication cycle, regardless of the command updating cycle.</li> </ul>
	Communication cycle 0.0833 ms	<ul style="list-style-type: none"> <li>Processes the command and response with a period of 0.1666 ms.</li> <li>Set the command updating cycle to 0.1666 ms.</li> </ul>						
	Other communication cycles	CP	<ul style="list-style-type: none"> <li>Calculates the changes in command position (CPOS) during command updating period and generates the movement command.</li> <li>If the command updating cycle on the servo driver is different from that on the host controller, operation error will occur.</li> <li>Processes commands and responses at a position other than the command position during communication cycle.</li> </ul>					
PP/CV/CT		<ul style="list-style-type: none"> <li>Processes commands and responses at the communication cycle, regardless of the command updating cycle.</li> </ul>						

Control mode	Abbreviation	Command code	Description
NOP	NOP	0□h	Use this mode when transmitting temporary invalid data immediately after establishment of the network. Never use this mode for any other purpose. Upon receiving this command, perform the control based on the previously received command.
Profile position mode	PP	1□h	Use this mode when operating by specifying target position, target speed and target acceleration/deceleration (parameter) and by generating position command in the servo driver.
Cyclic position mode	CP	2□h	Use this mode when operating by generating position command in the host controller and by updating (transmitting) the command position at the command updating cycle.
Cyclic velocity mode	CV	3□h	Use this mode when operating by generating velocity command in the host controller and by updating (transmitting) the command velocity at the communication cycle.
Cyclic torque mode	CT	4□h	Use this mode when operating by generating torque command in the host controller and by updating (transmitting) the command torque at the communication cycle.

## 2-5-1 Mode reference table [Under review]

MINAS-A5N is compatible with the communication cycle, command updating cycle, control mode and data size shown in the table below.

In the full- closed control mode, MINAS-A5N supports only position control (PP, CP). CV and CT cannot be selected.

## (1) 16 byte mode

● Compatible with both semi- and full- closed system; ○ Compatible only with semi-closed system;

-: Compatible with no system

Communication period (ms)	Command update period (ms)											
	0.1666				0.5				1.0			
	PP	CP	CV	CT	PP	CP	CV	CT	PP	CP	CV	CT
0.0833	-	○	○	○	-	-	-	-	-	-	-	-
0.1666	-	○	○	○	-	-	-	-	-	-	-	-
0.5	/				●	●	○	○	●	●	○	○
1.0	/				/				●	●	○	○

\*When an external scale position information monitoring facility at the semi-closed control (bit4 of Pr7.22) is validated, below 0.1666 [ms] or less communication period does not correspond. (except for NOP)

## (2) 32 byte mode

● Compatible with both semi- and full- closed system; ○ Compatible only with semi-closed system;

-: Compatible with no system

Communication period (ms)	Command update period (ms)											
	0.1666				0.5				1.0			
	PP	CP	CV	CT	PP	CP	CV	CT	PP	CP	CV	CT
0.0833	-	-	-	-	-	-	-	-	-	-	-	-
0.1666	-	-	-	-	-	-	-	-	-	-	-	-
0.5	/				●	●	○	○	●	●	○	○
1.0	/				/				●	●	○	○

## 2-5-2 Related Parameter

Class	No.	Attribute	Title	Setup range	Unit	Function
0	01	R	Control mode setup	0-6	-	You can set up the control mode to be used. 0: semi-closed control Selectable between position (PP/CP), velocity (CV) and torque (CT) controls 6: Full-closed control Position (PP/CP) control only Others (can be set only by the manufacturer and not by the user)
7	20	R	RTEX communication cycle setup	1-12	-	Set up the RTEX communication cycle. 0: 0.0833 (ms) 1: 0.1666 (ms) 3: 0.5 (ms) 6: 1.0 (ms) Others (can be set only by the manufacturer and not by the user)
7	21	R	RTEX command updating cycle ratio setup	1-2	-	Set up the ratio of RTEX communication cycle to command updating cycle. Setting = command updating cycle to communication cycle ratio 1: 1 (time) 2 2 (times) (valid only when communication period are 0.0833, 0.5 ms)
7	22	R	RTEX function expansion setup 1	-32768-32767	-	[bit 0] specifies the data size of RTEX communication. 0: 16-byte mode 1: 32-byte mode [bit 1] specifies the inter-axis sync mode when 2 or more axes are used with TMG_CNT. Set this parameter to 0 when not using TMG_CNT. 0: Interaxis semi-synchronous mode 1: Interaxis full-synchronous mode ▪ For details, refer to 4-2-1-1. [bit2]: For manufacturer's use. Always set to 0 [bit3]: unused. Always set to 0 [bit4]: External scale position information monitoring facility at the semi-closed control. 0: invalid 1: valid *In the full- closed control mode,monitored the external scale position regardless of the setting of this bit.

## Note:

Make sure to set the same cycle as the upper equipment for the RTEX communication cycle (Pr7.20) and RTEX command updating cycle (Pr7.21).

Also, make sure to set the same setting as the upper equipment for the extended RTEX function (Pr7.22).

Otherwise, the operation cannot be guaranteed.

## 2-5-3 Example of mode setup

Communication period of 0.5 ms, command updating period 1.0 ms, semi-closed control, 16-byte mode and interaxis semi-synchronous mode

- Pr.0.01 = 0 (Semi-closed control)
- Pr.7.20 = 3 (Communication cycle 0.5 ms)
- Pr.7.21 = 2 (Command updating cycle 1.0 ms = 0.5 ms × 2)
- Pr.7.22 = 0 (16-byte mode and interaxis semi-synchronous mode)

In this example setting, CP/CV/CT control mode selection is necessary by specifying command code.

## Note:

If matching condition of Pr.7.20 RTEX communication cycle setup and Pr.7.21 RTEX command updating cycle setup is not established, Err.93.5 Parameter setup error protection 4 will be generated.

## 2-6 COM LED, LINK LED and RTEX communication state

The table below shows display state of COM LED and LINK LED and RTEX communication status.

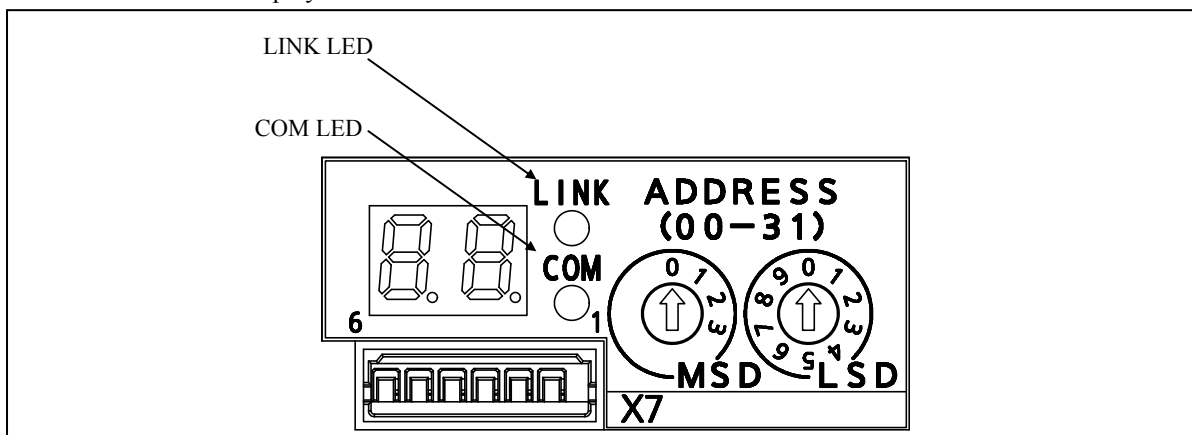

#### ■ COM LED

State	Description				
	RTEX communication state	Pr.7.23 bit 4 = 0		Pr.7.23 bit 4 = 1	
		MNM1221 state *1)	Communication and servo are Synced	MNM1221 state *1)	Communication and servo are Synced
OFF	Not established	• INITIAL	Not dependent	• INITIAL	Not established
Flashing Green	Under configuring	• RING_CONFIG • READY		• RING_CONFIG • READY • RUNNING	Not established
Solid Green	Established	• RUNNING		• RUNNING	Not established
Flashing Red	Clearable alarm relating to RTEX communication has occurred.				
Solid Red	Non-clearable alarm relating to RTEX communication has occurred.				

\*1) MNM1221 is an ASIC developed to control RTEX communication.

#### ■ LINK LED

State	Description
OFF	Non-connecting (No power entry of transmitter node, or cable disconnection)
Solid Green	Proper connecting (“TX” of transmitter node and own “RX” is electrically connected)

- If RTEX communication related alarm occurs while non-RTEX alarm (e.g. Err. 16.0) has occurred, COM LED shows the new alarm by lighting or flashing in red as described above.  
Note that the 7-seg LED still displays the non-RTEX related alarm.
- Upon power up or upon issuing of the reset command, LINK LED will blink once. This is normal because the LED is initialized by the servo driver.
- Lighting condition of COM LED can be changed by the setting of bit 4 of Pr.7.23 RTEX function expansion setup 2.



### 3. Transmission Protocol of RTEX Communication Data

#### 3-1 Transmission timing of data

- If the synchronization between the communication and servo is not established, the command receiving timing and response transmitting timing are unstable.  
The timing diagram in this chapter shows established synchronization which can be verified through the logic output signal (extended portion) of the monitor command.
- Because the echo back of the Update\_Counter is generated in the data exchanging process of the servo driver, the echo back (Update\_Counter\_Echo) is immediately returned unless a communication error occurs.
- In contrast, the echo back (Command\_Code\_Echo) in response to the command code is not immediately returned because it is generated in command/response process. Relationship between Update\_Counter and command code may not be the same for transmitted data and received data.
- If the control mode is switched to a different control mode when the communication cycle is 0.0833 ms or 0.1666 ms, the response timing of the command code echo back is different from the response timing of internal data e.g. position deviation which depends on the control mode. For details, refer to timing diagram in 3-1-3 and 3-1-4.
- If the command is not correctly received due to problem caused by command code or argument, the command error bit (CMD\_Error or Sub\_CMD\_Err) is set to 1 and returned. When the servo driver correctly receives the command, the command error bit is set to 0.  
For secure command transfer, hold the command code value until the echo back is received.

3-1-1 Transmission timing of communication period 0.5 ms/command updating period 0.5 ms

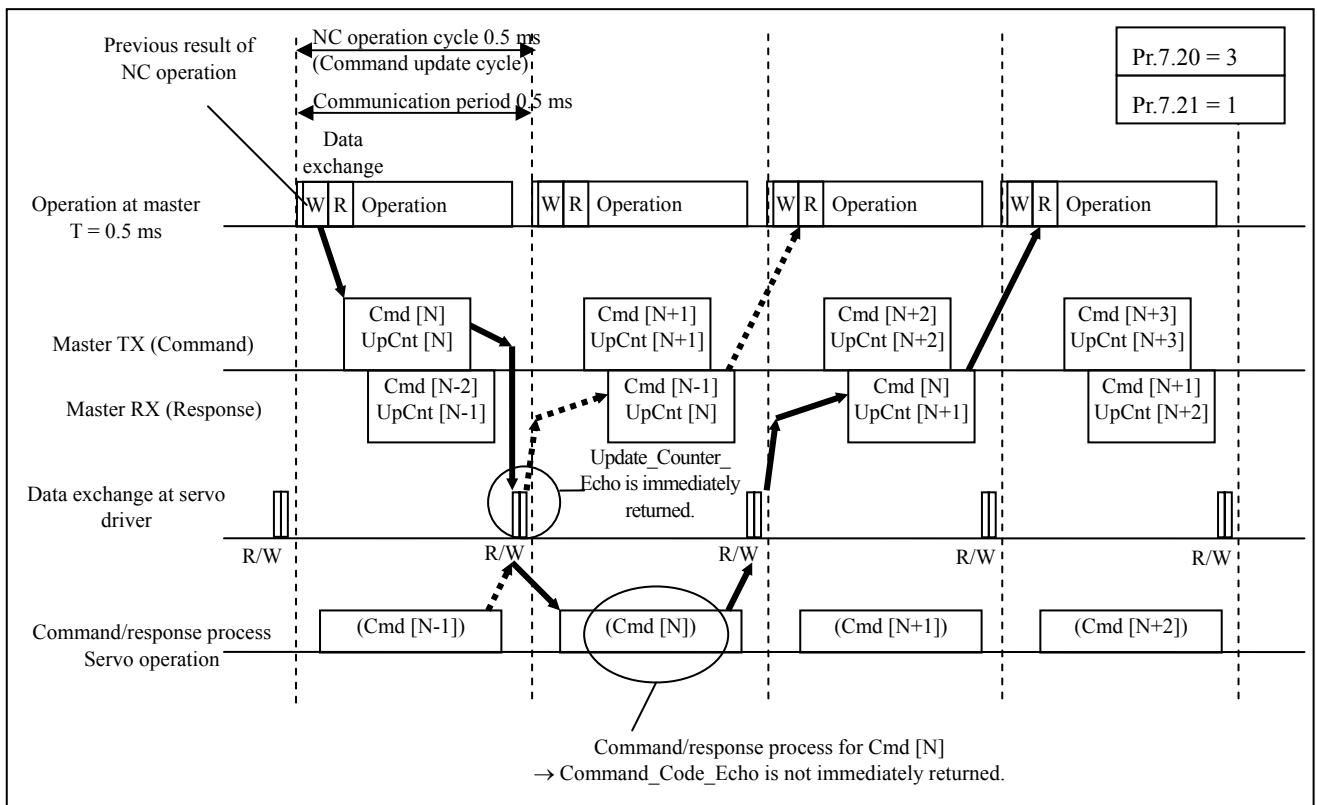

3-1-2 Transmission timing of communication cycle 0.5 ms/command updating cycle 1.0 ms

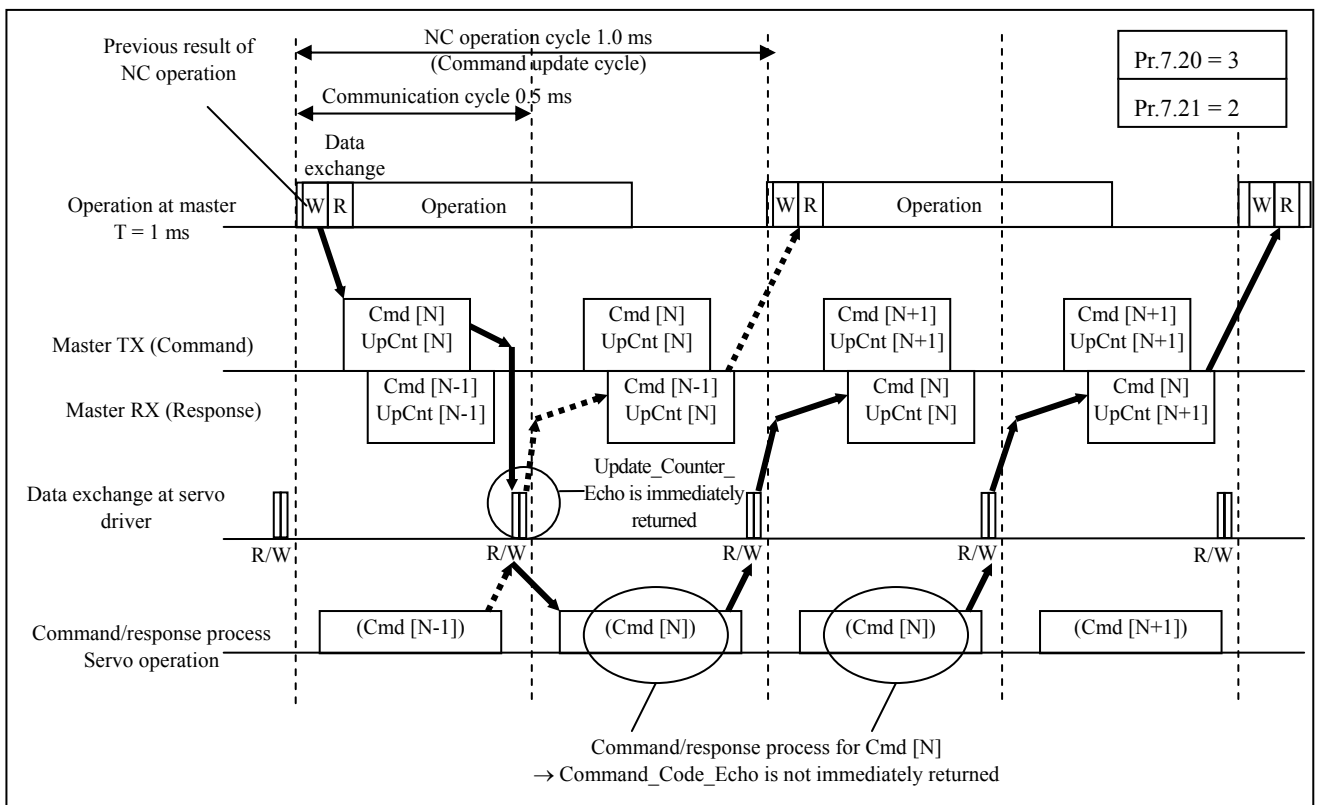

3-1-3 Transmission timing of communication cycle 0.1666 ms/command updating cycle 0.1666 ms

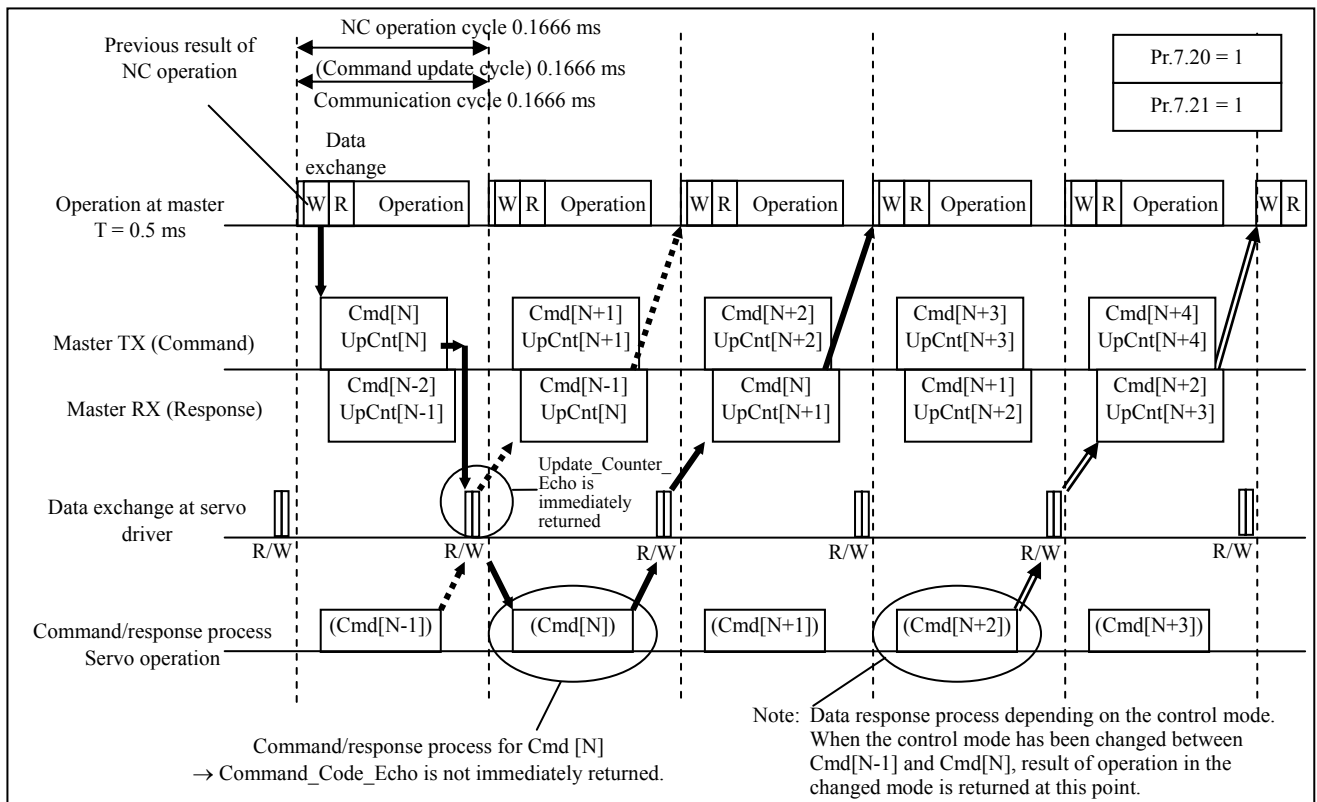

3-1-4 Transmission timing of communication cycle 0.0833 ms/command updating cycle 0.1666 ms

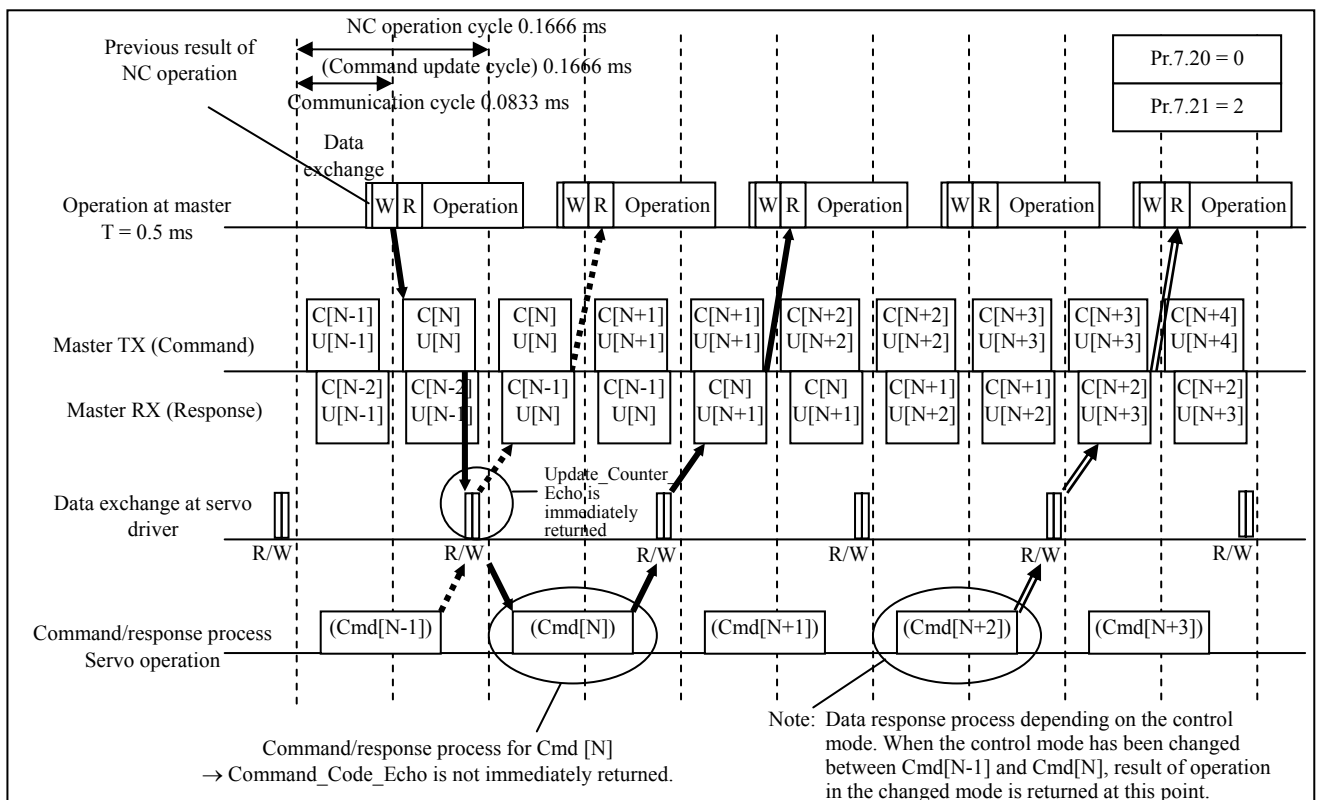

3-1-5 Transmission timing of communication cycle 1.0 ms/command updating cycle 1.0 ms

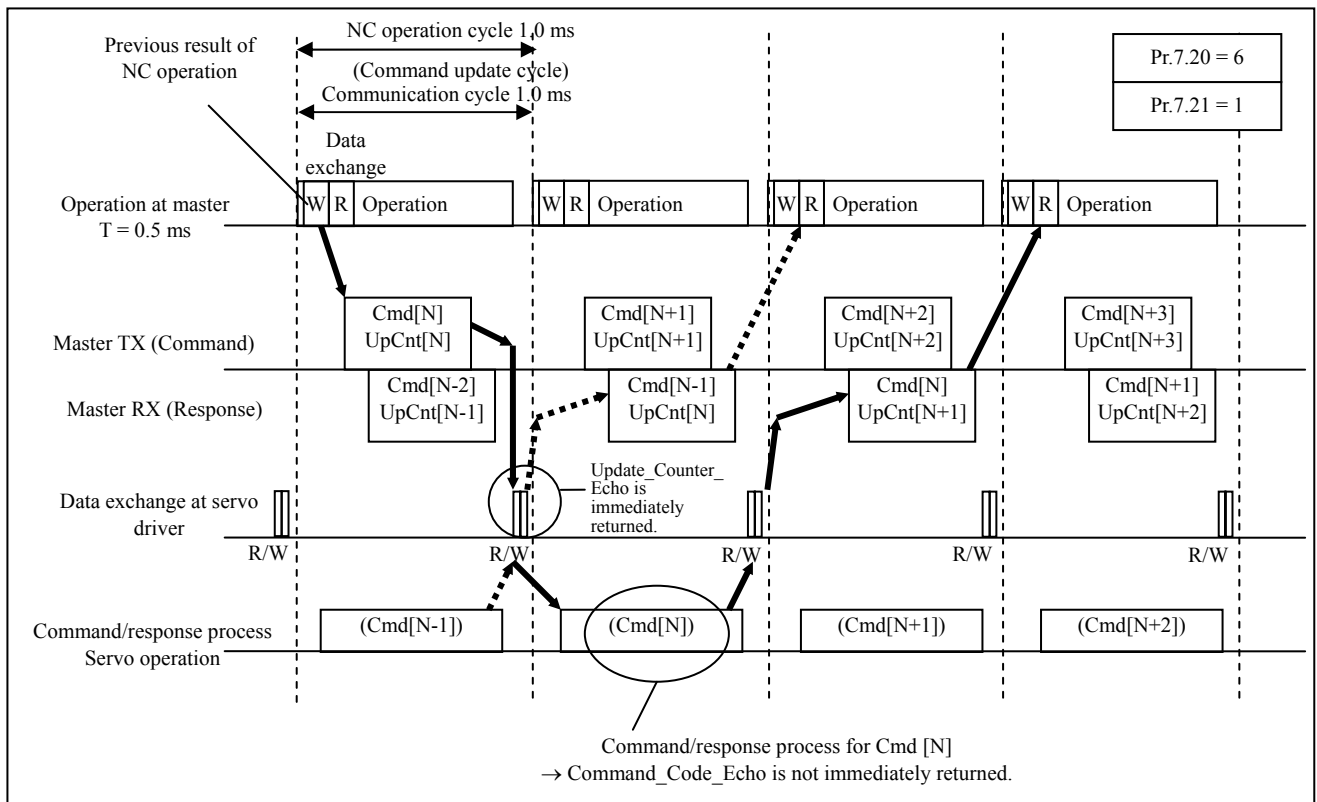

### 3-2 Transmission of cyclic data

#### 3-2-1 Cyclic transmission area

Use bytes 2 to 7 in command/response data block or bytes 24 to 31 in the 32-byte mode, as cyclic transmission area for real-time data such as command position and feedforward data.

Use bytes 12 to 15 (Command\_Data3) in command data block as cyclic transmission area by using Pr.7.35 (RTEX command setting 1). For details, refer to 7-7.

Use bytes 8 to 15 (Reponse\_Data2/3) in response data block, or bytes 20 to 23 (Sub\_Response\_Data1) in the 32-byte mode, as cyclic transmission area by using Pr.7.30 to Pr.7.32 (RTEX monitor select 2/3/4). For details, refer to 4-3-1.

There is no special transmission procedure for the cyclic command area data. The servo driver will reflect the received cyclic command data in the control at once, and will return the latest value of the cyclic response data.

#### ■ Main command: common to 16 byte and 32 byte mode

	Byte	Command								Byte	Response									
		bit7	6	5	4	3	2	1	0		bit7	6	5	4	3	2	1	0		
Cyclic	0	C (0)	Update_Counter		MAC-ID				0	R (1)	Update_Counter Echo		Actual MAC-ID							
	1	TMG_ CNT	Command_Code								1	CMD_ Error	Command_Code_Echo							
	2	Control_Bits								2	Status_Flags									
	3									3										
	4									4										
	5	Command_Data1								5	Response_Data1									
	6									6										
Non-Cyclic	7									7										
	8	Command_Data2								8	Response_Data2									
	9									9										
	10									10										
	11									11										
	12	Command_Data3								12	Response_Data3									
	13									13										
	14									14										
	15									15										

#### ■ Sub-command: specific to 32 byte mode

	Byte	Command								Byte	Response							
		bit7	6	5	4	3	2	1	0		bit7	6	5	4	3	2	1	0
Non-cyclic	16	Sub_ Chk	0	0	0	Sub_Command_Code			16	Sub_ CMD_ Err	Sub_ ERR	Sub_ WNG	Sub_ Busy	Sub_Command_Code_Echo				
	17	Sub_Type_Code								17	Sub_Type_Code_Echo							
	18	Sub_Index								18	Sub_Index_Echo							
	19									19								
	20	Sub_Command_Data1								20	Sub_Response_Data1							
Cyclic	21									21								
	22									22								
	23									23								
	24	Sub_Command_Data2								24	Sub_Response_Data2							
	25									25								
	26									26								
	27									27								
28	Sub_Command_Data3								28	Sub_Response_Data3								
29									29									
30									30									
31									31									

## 3-3 Transmission of Non-Cyclic Data

## 3-3-1 Non-cyclic transmission area

Use bytes 8 to 15 in Command/Response Data Block and bytes 17 to 23 in 32-byte mode as Non-cyclic transmission area for event-driven data such as parameter setup.

■ Main command: common to 16 byte and 32 byte mode

	Byte	Command								Byte	Response									
		bit7	6	5	4	3	2	1	0		bit7	6	5	4	3	2	1	0		
Cyclic	0	C (0)	Update_Counter		MAC-ID				0	R (1)	Update_Counter_Echo		Actual MAC-ID							
	1	TMG_CNT	Command_Code								1	CMD_Error	Command_Code_Echo							
	2	Control_Bits								2	Status_Flags									
	3																			
	4	Command_Data1								4	Response_Data1									
	5																			
	6																			
7																				
Non-cyclic	8	Command_Data2								8	Response_Data2									
	9																			
	10																			
	11	Command_Data3								11	Response_Data3									
	12																			
	13																			
	14																			
15																				

■ Sub-command: specific to 32 byte mode

	Byte	Command								Byte	Response							
		bit7	6	5	4	3	2	1	0		bit7	6	5	4	3	2	1	0
Non-cyclic	16	Sub_Chk	0	0	0	Sub_Command_Code			16	Sub_CMD_Err	Sub_ERR	Sub_WNG	Sub_Busy	Sub_Command_Code_Echo				
	17	Sub_Type_Code								17	Sub_Type_Code_Echo							
	18	Sub_Index								18	Sub_Index_Echo							
	19	Sub_Command_Data1								19	Sub_Response_Data1							
	20																	
	21																	
	22	Sub_Command_Data2								22	Sub_Response_Data2							
23																		
24																		
25																		
Cyclic	26	Sub_Command_Data3								26	Sub_Response_Data3							
	27																	
	28																	
	29	Sub_Command_Data3								29	Sub_Response_Data3							
	30																	
	31																	

## 3-3-2 Non-cyclic status flag

Byte 9, bits 7–4 in the response show the status of the non-cyclic command, if the command is not a normal one (□0h).

Bit	Title	Description
7	ERR	Set to 1 when error occurs during process after reception of the command.
6	WNG	Set to 1 when the command is processed but with certain problem, e.g. written with restriction during parameter setting.
5	Reserved	Always return 0.
4	Busy	Kept at 1 while command is processed.

Byte 16, bits 6–4 in the response show the status of the sub-command in the 32-byte mode.

Bit	Title	Description
6	Sub_ERR	Set to 1 when error occurs during process after reception of the command.
5	Sub_WNG	Set to 1 when the command is processed but with certain problem.
4	Sub_Busy	Kept at 1 while command is processed.

## 3-3-3 Non-cyclic command startup mode setting

To set start-up condition of the non-cyclic command, use Pr.7.23 (REX function expansion setup 2).

To make this condition compatible with MINAS-A4N, set bit 5 to 0.

Class	No.	Attribute	Title	Setup range	Unit	Function									
7	23	B	RTEX function expansion setup 2	-32768 to 32767	—	[bit 5] sets non-cyclic command startup mode <table border="1"> <thead> <tr> <th>Value</th> <th>Function</th> <th>See</th> </tr> </thead> <tbody> <tr> <td>0</td> <td>(MINAS-A4N compatible mode) Changing from standard command</td> <td>3-3-4</td> </tr> <tr> <td>1</td> <td>(Extend mode) Upon changing command mode and command argument</td> <td>3-3-5</td> </tr> </tbody> </table>	Value	Function	See	0	(MINAS-A4N compatible mode) Changing from standard command	3-3-4	1	(Extend mode) Upon changing command mode and command argument	3-3-5
Value	Function	See													
0	(MINAS-A4N compatible mode) Changing from standard command	3-3-4													
1	(Extend mode) Upon changing command mode and command argument	3-3-5													



## 3-3-4 Startup of non-cyclic command (MINAS-A4N compatible mode)

When transmitting non-cyclic command (including sub-command) in the MINAS-A4N compatible mode (Pr.7.23, bit 5 = 0), follow the procedure described below.

- 1) Be sure to change the code from the standard command (e.g. 20h) to the desired non-cyclic command. (Set also Type\_Code, Index, Command\_Data3, etc., at the same time or beforehand.)
- 2) Hold the command until the normal echo-back is returned.
- 3) When normal echo-back is returned and Busy bit is 0, get the necessary data after checking ERR bit and WNG bit. After that, bring the command code back to the standard command (e.g. normal command: 20h).

Standard command	Description
10h, 20h, 30h, 40h	<p>These are reference command for handshaking when transferring non-cyclic command.</p> <p>Normal command (□0h) serves as standard command.</p> <ul style="list-style-type: none"> <li>▪ If a sub-command, Sub_Command_Code = 0h is the standard command.</li> </ul>

The change of command code is the trigger for executing the process. Only one process will be executed per one trigger.

■ Example: Operating procedure of non-cyclic command when changing parameter

When changing the multiple parameters continuously, it is necessary to bring the command code back to the standard command (e.g. normal command: 20h) every time a parameter is changed.

Note that the process will not be executed only with changing the parameter number.

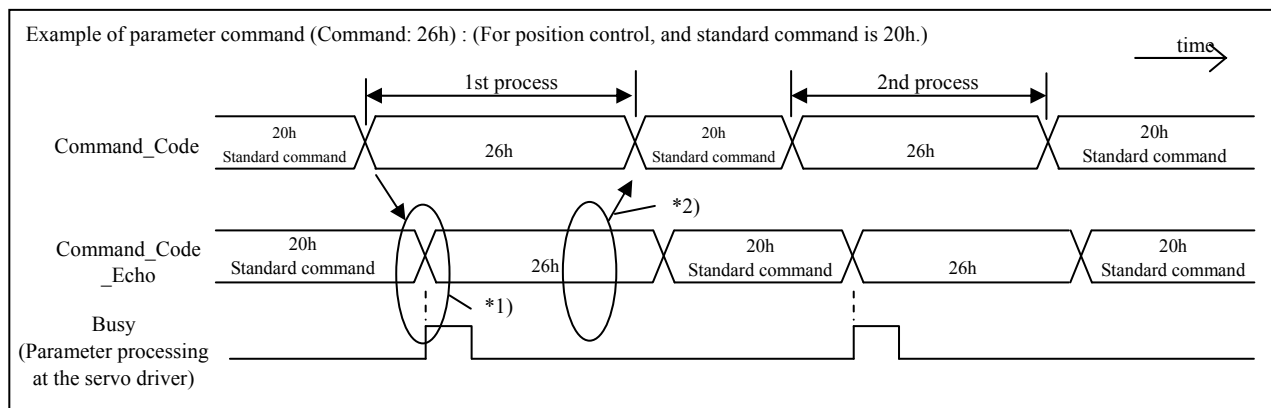

\*1) Parameter process will be executed in the servo driver at the transition from normal command (20h) to parameter command (26h).

The servo driver will execute one process at transition of command code when it receives the same command during multiple communication cycles. (edge process)

\*2) Make sure that Busy is 0 and check for normal echo of command code (including Type\_Code etc.), and then return to the normal command (20h).

## 3-3-4-1 Basic sequence of non-cyclic command

(When position control and the standard command is 20h)

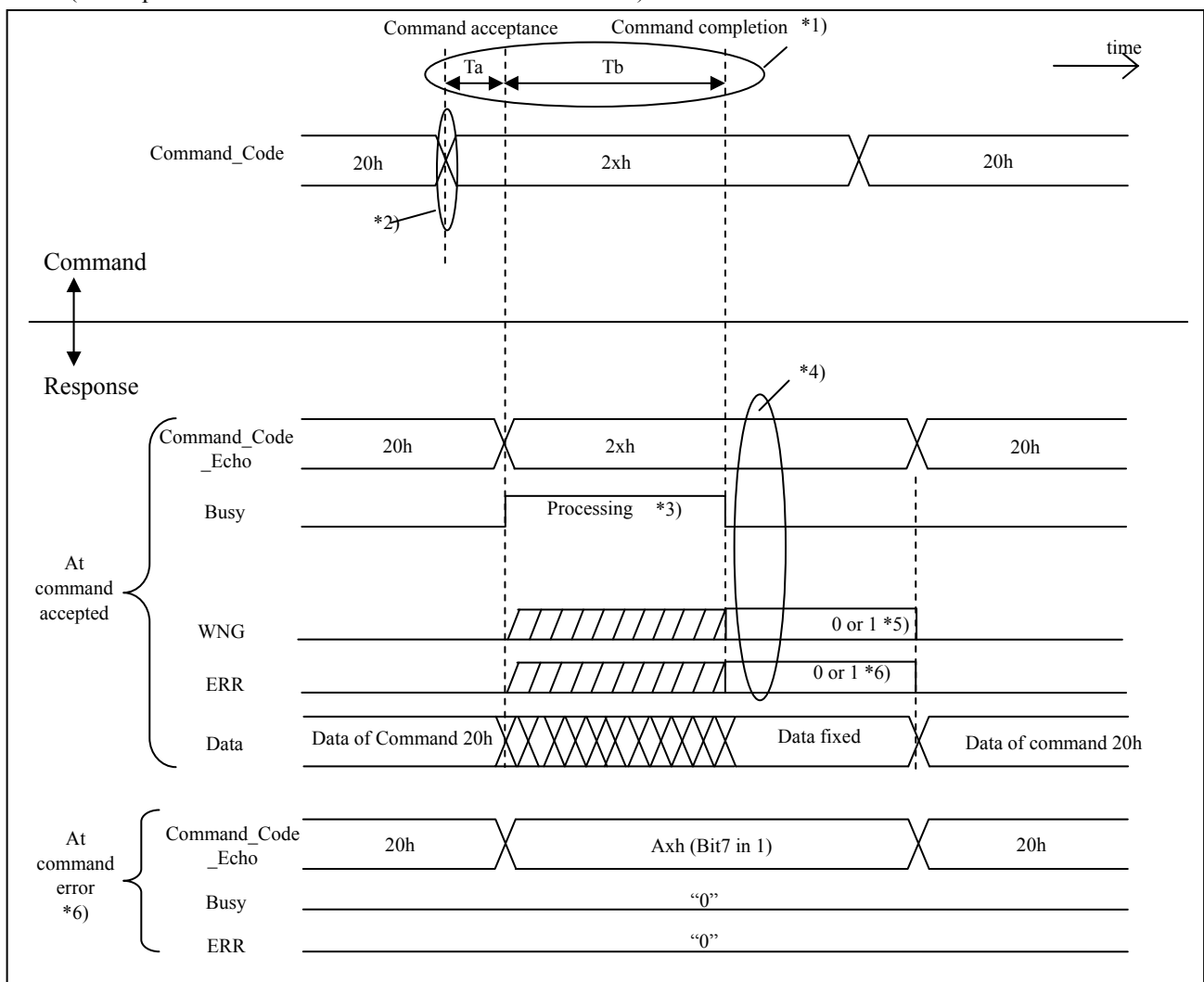

\*1) Time of Ta and Tb depend on command.

In most reading processes, Tb will be 0 and Busy is not 1.

\*2) Change of command code will be the trigger for executing the process.

\*3) When you execute another non-cyclic command during processing (Busy is 1), command error (0101h) will occur.

\*4) After confirming Busy is 0 (the process is completed), bring the command back to normal command (20h). The servo driver will continue to process even if command is returned to normal command during processing. (Note that part of homing process will be aborted.)

\*5) WNG bit will be 1 when a problem occurs even though the process has been executed. (The parameter was set to the limited value that is different from the command value.)

\*6) Command error shows whether the command could be accepted or not, and will be detected before executing the process.

Some kind of errors during processing will be shown in ERR bit instead of command error. An error might occur in some command (e.g. writing parameters to EEPROM) during processing. In such a case, retry the command after confirming that ERR bit becomes 1.

3-3-4-2 Read sequence of non-cyclic command  
 (When position control and the standard command is 20h)

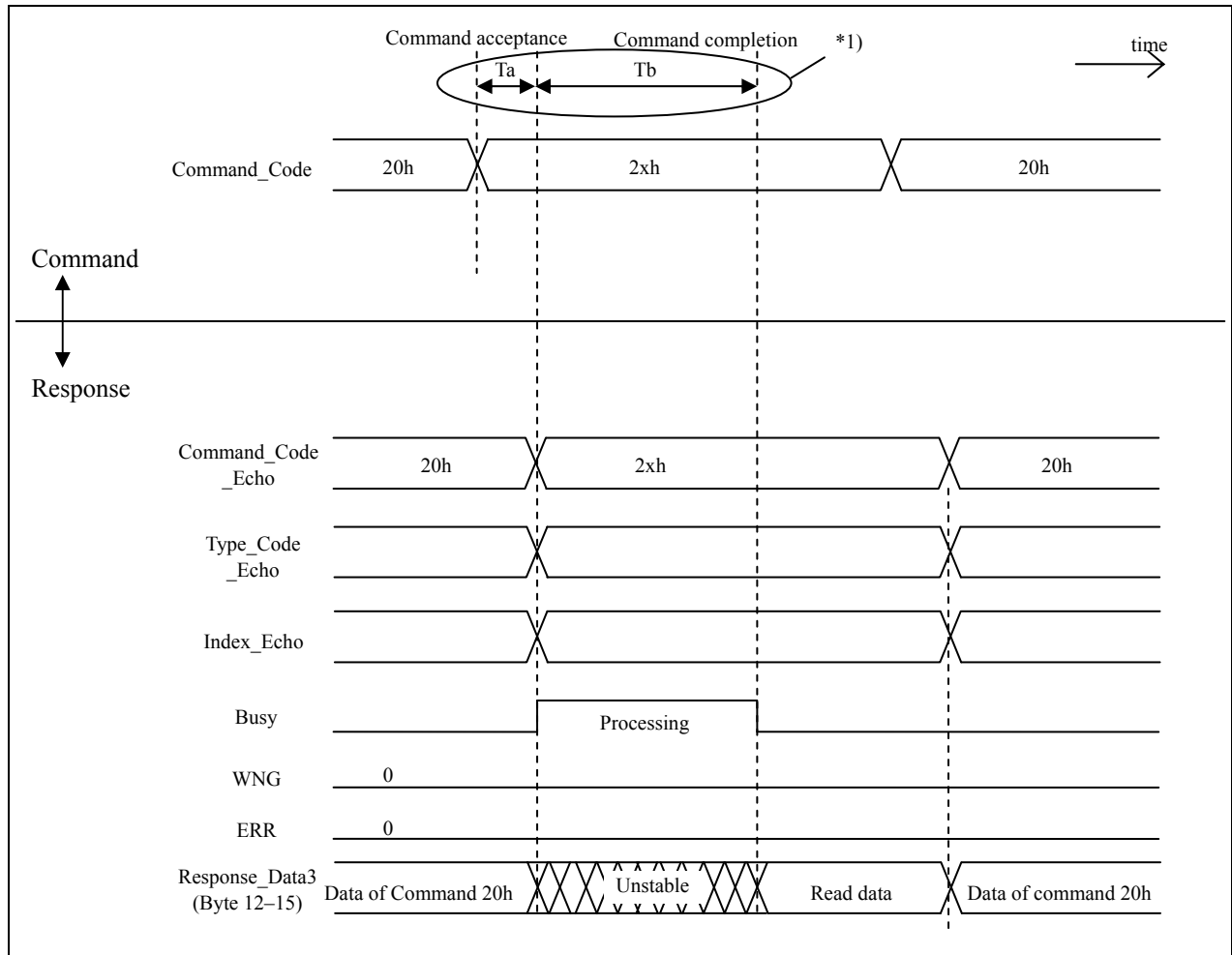

\*1) Times of Ta and Tb depend on the command.  
 In most reading cases, Busy will not be 1. (Tb is 0.)

## 3-3-4-3 Write sequence of non-cyclic command

(When position control and the standard command is 20h)

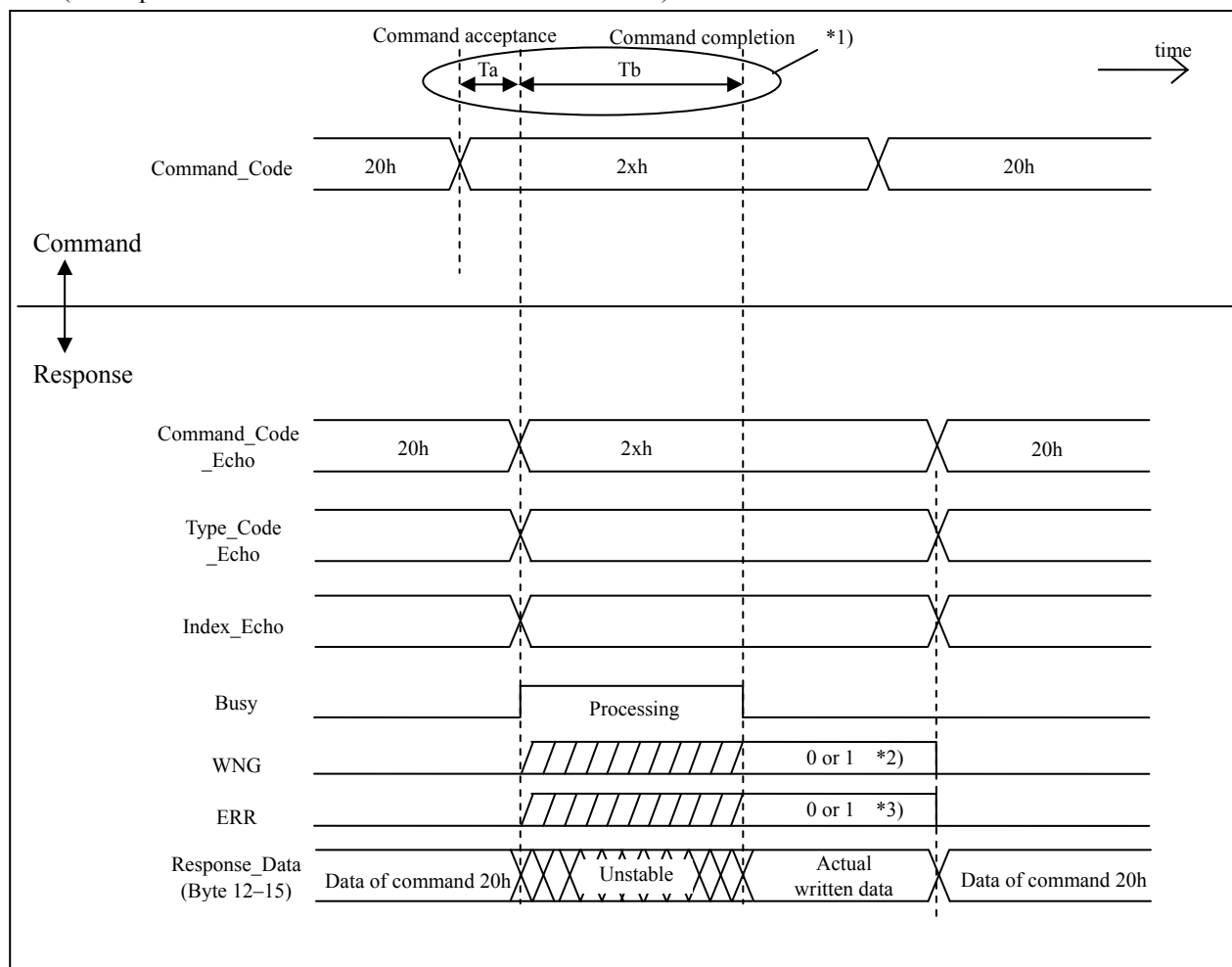

\*1) Times of  $T_a$  and  $T_b$  depend on command.

\*2) WNG bit will be 1 when a problem occurs even though the process has been executed.  
(The parameter was set to the limited value that is different from the command value.)

\*3) An error might occur in some command (e.g. writing parameters to EEPROM) during processing. In this case, ERR bit will be 1 and retry the command.

### 3-3-5 Startup of non-cyclic command (extend mode)

By setting non-cyclic command startup condition to the extend mode (Pr.7.23, bit 5 = 1), non-cyclic command can be started in the following condition as well as upon changing from the standard command. Because this condition is not applicable to certain commands, refer to individual command descriptions"Section5,6".

- 1) Upon changing non-cyclic command code or sub-command code
- 2) Upon changing command argument (Command\_Data2, Command\_Data3)  
Note: Not applied to Command\_Data3 in feed forward data setting  
Sub-command argument: Sub\_Type\_Code, Sub\_Index or Sub\_Command\_Data1

#### ■ Precautions

- Do not use this mode if two or more data which must be changed simultaneously cannot be updated at 1 cycle.
- Profile operation starts upon changing the command code from the normal command (10h) to profile command (17h).  
Exception: When the target position or target speed is updated during profile operation, the servo drive will response to the change if the target position (TPOS) or target speed (TSPD) is changed while the command code 17h is maintained.

#### 4. RTEX Communication Data Block

This chapter describes the one or two data blocks (16 bytes or 32 bytes per slave axis) assigned to Transmission/reception memory in the communication ASIC “MNM1221”.

##### 4-1 Transmission and reception memory in MNM1221

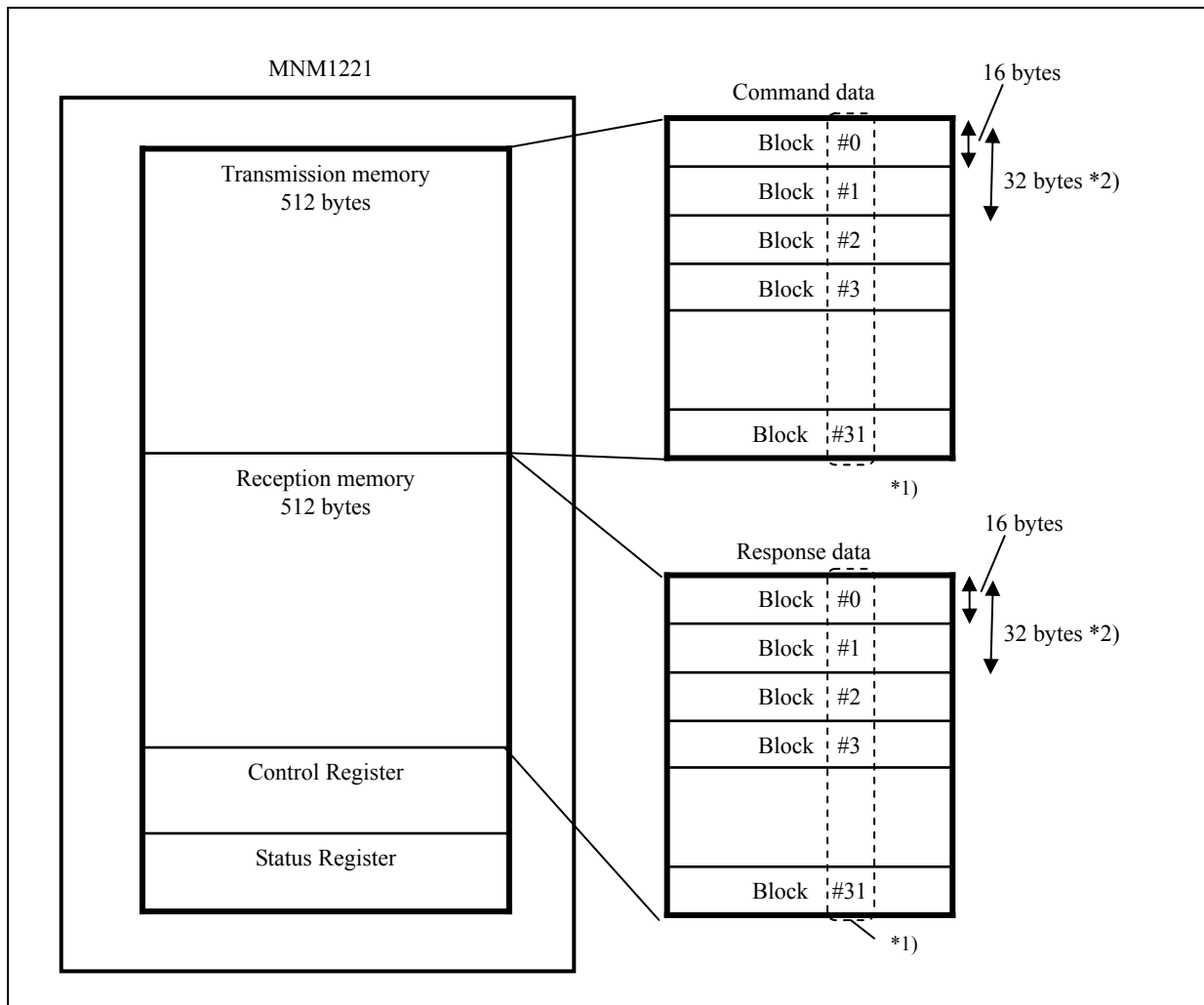

\*1) Data block numbers, #0 to #31 represent the connecting order of the slaves.

Note that these are not the node addresses (MAC-ID).

\*2) The slave set to 32-byte mode uses 2 consecutive 16-byte data blocks.

## 4-2 Command data block arrangement (16-byte/32-byte mode)

Command will be transmitted from the master (host controller) to slave (servo driver).

Byte	bit 7	bit 6	bit 5	bit 4	bit 3	bit 2	bit 1	bit 0
0	C/R(0)	Update_Counter		MAC-ID (0 to 31)				
1	0	Command_Code						
2	Servo_On	0	0	Gain_SW	TL_SW	Homing_Ctrl	0	0
3	Hard_Stop	Smooth_Stop	Pause	0	SL_SW	0	EX-OUT2	EX-OUT1
4	Command_Data1							L
5								ML
6								MH
7								H
8	Command_Data2							L
9								ML
10								MH
11								H
12	Command_Data3							L
13								ML
14								MH
15								H

- Notes:
- Command code of byte 1 defines the contents from byte 4 to byte 15.
  - Disposition of multiple byte data is little endian, which means that lower byte is first.
  - Set the unused bit to 0.

4-2-1 Command code and command argument (Command bytes 1, 4–15)

Byte	bit 7	bit 6	bit 5	bit 4	bit 3	bit 2	bit 1	bit 0
1	0	Command_Code						
4–7	Command_Data1							
8–11	Command_Data2							
12–15	Command_Data3							

Title	Description
Command_Code	<ul style="list-style-type: none"> <li>Set up the command code.</li> <li>Command code is classified into two types as cyclic command code for transmitting real-time data such as command position and non-cyclic command code for transmitting event-driven data such as parameter setup.</li> <li>Cyclic command code is assigned to bit 6 to 4 in byte 1 of command, and specifies the data for byte 4 to 7.</li> <li>Non-cyclic command code is assigned to bit 3 to 0 in byte 1 of command, and specifies the data for byte 8 to 15.</li> <li>Use of unsupported cyclic command causes Err. 86.1 RTEX cyclic data error protection 2 alarm.</li> <li>See the figure below for details.</li> </ul>
TMG_CNT	<ul style="list-style-type: none"> <li>Use in inter-axis full synchronous mode. For details, refer to 4-2-1-1.</li> </ul>
Command_Data1	<ul style="list-style-type: none"> <li>Set up the command data specified by cyclic command code.</li> <li>For details, refer to the command description (Chapters 5 and 6).</li> </ul>
Command_Data2	<ul style="list-style-type: none"> <li>Set up the command data specified by non-cyclic command code.</li> <li>For details, refer to the command description (Chapters 5 and 6).</li> </ul>
Command_Data3	<ul style="list-style-type: none"> <li>Set up the command data specified by non-cyclic command code.</li> <li>For details, refer to the command description (Chapters 5 and 6).</li> </ul>

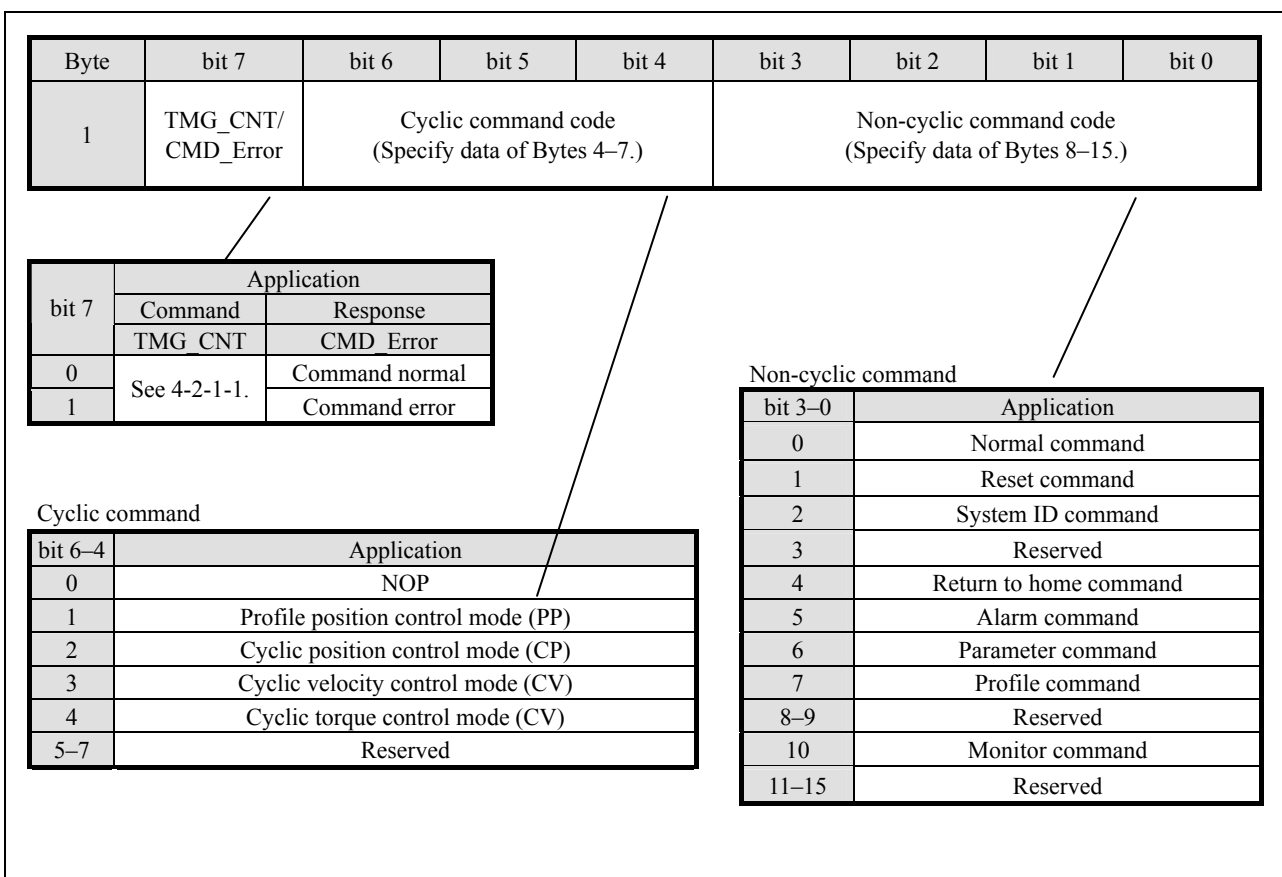

Set the cyclic command code to NOP (bits 6–4:0) only when transmitting invalid data after canceling the reset, and specify the control mode to be used (PP, CP, CV or CT). Do not transmit NOP.

For details of each command, refer to Chapters 5 and 6.



## 4-2-1-1 TMG\_CNT setup and inter-axis synchronous mode

When bit 1 of Pr.7.22 (RTEX function expansion setup 1) is set at 1, the servo driver syncs its all internal control cycles to the timing of TMG\_CNT.

Category	No.	Attribute	Parameter	Setting range	Unit	Description
7	22	R	RTEX function expansion setup 1	-32768 -32767	-	<p>[bit 0] Set the data size of RTEX communication. 0: 16-byte mode 1: 32-byte mode</p> <p>[bit 1] Set the inter-axis synchronous mode that uses TMG_CNT. When not using TMG_CNT, set this bit to 0. 0: Inter-axis semi-synchronous mode 1: Inter-axis full-synchronous mode</p> <p>[bit 2] For manufacturer's use. Always set to 0</p> <p>[bit 3] unused. Always set to 0</p> <p>[bit4]: External scale position information monitoring facility at the semi-closed control. 0: invalid 1: valid</p>

## (1) Inter-axis semi-synchronous mode (Pr.7.22, bit 1 = 0)

In this mode, inter-axis synchronization will fail in some functions (e.g. analog monitoring), although receiving timing of operation instructions such as position instruction is coincident.

- Do not use TMG\_CNT.

## (2) Inter-axis full-synchronous mode (Pr.7.22, bit 1 = 1)

This mode is used when MINAS-A5N's all internal control process start timings between 2 or more axes are to be synchronized. Some functions (e.g. analog monitoring) other than operation instructions may also be synchronized.

- Set the same value to the TMG\_CNT for all axes and update the count every 2 ms.
- If TMG\_CNT is not counted up correctly, communication is not established (COM\_LED is not lit in green) or inter-axis synchronization is not established.
- The time necessary to establish the communication (COM-LED is lit in green) varies depending on a pair of axes to be synchronized.
- Even if synchronization is established, inter-axis synchronization will not be established when start-stop communication error occurs at the start of the operation (especially at the beginning of the PP control mode).

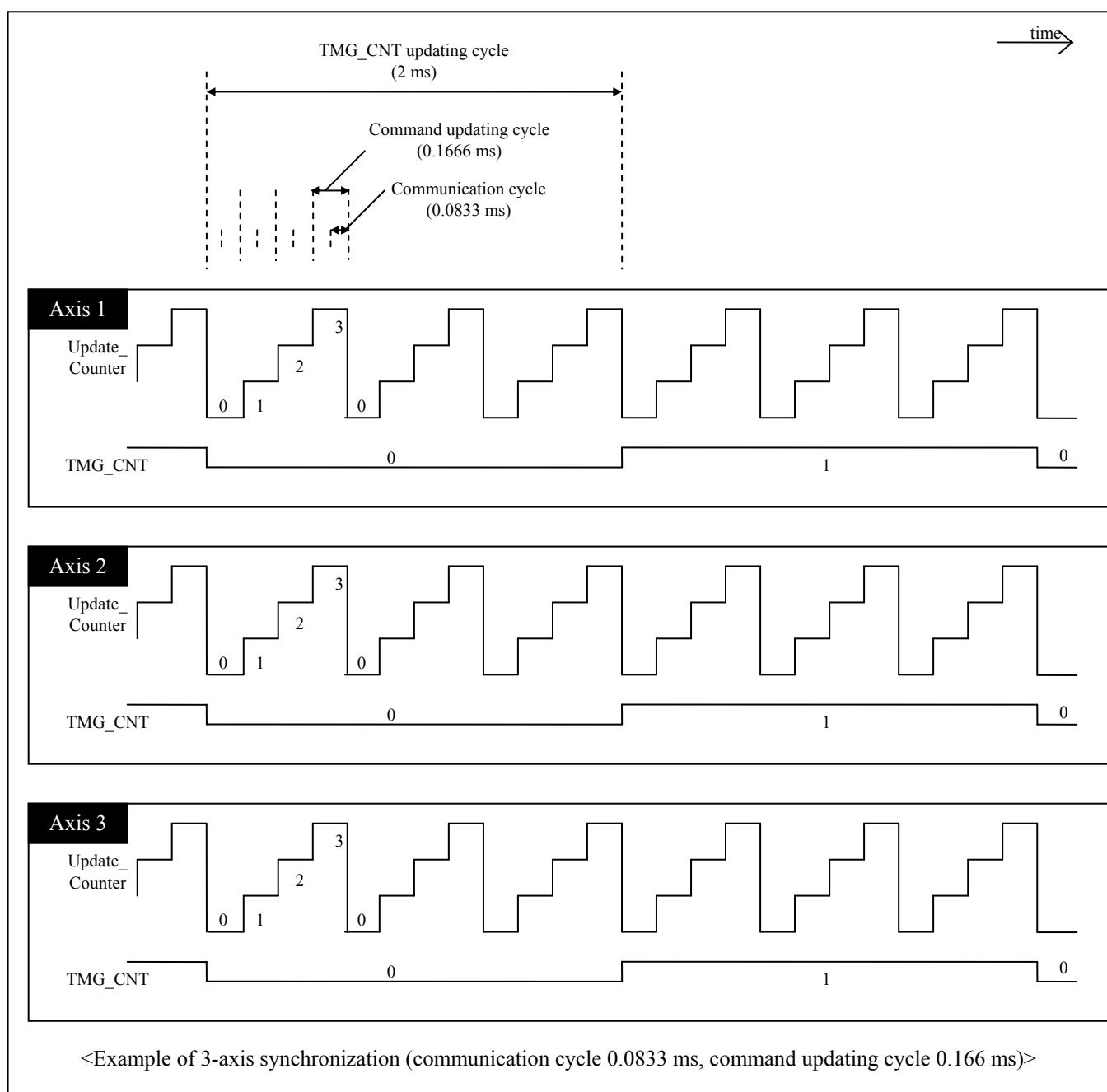

## 4-2-2 Command header (command byte 0)

Byte	bit 7	bit 6	bit 5	bit 4	bit 3	bit 2	bit 1	bit 0
0	C/R(0)	Update_Counter			MAC-ID (0-31)			

Title	Description
C/R	<ul style="list-style-type: none"> <li>C/R bit distinguish command and response.</li> <li>Set this bit to 0 in command.</li> <li>If this bit is set to level other than 0, Err. 86.0 RTEX cyclic data error protection 1 alarm will be generated.</li> </ul>
Update_Counter	<ul style="list-style-type: none"> <li>Set the count up value at the command updating cycle.</li> <li>The purpose is to detect the command updating timing at servo driver.</li> <li>The servo driver echoes back this data in the response, the counter can also be used as the watchdog timer.</li> </ul>
MAC-ID	<ul style="list-style-type: none"> <li>Set up the node address of the servo driver.</li> <li>If a node address different from actual setting value is used, Err. 86.0 RTEX cyclic data error protection 1 alarm will be generated.</li> </ul>

## 4-2-2-1 Update\_Counter setup

Be sure to count up Update\_Counter every command updating cycle at the data updating timing of the host controller. Otherwise, operation command is not correctly received.

Because the counter used here is for the purpose of transferring the command updating timing to the servo driver, regardless of actual updating process, count up operation must be done even if the content of the command data block is unchanged.

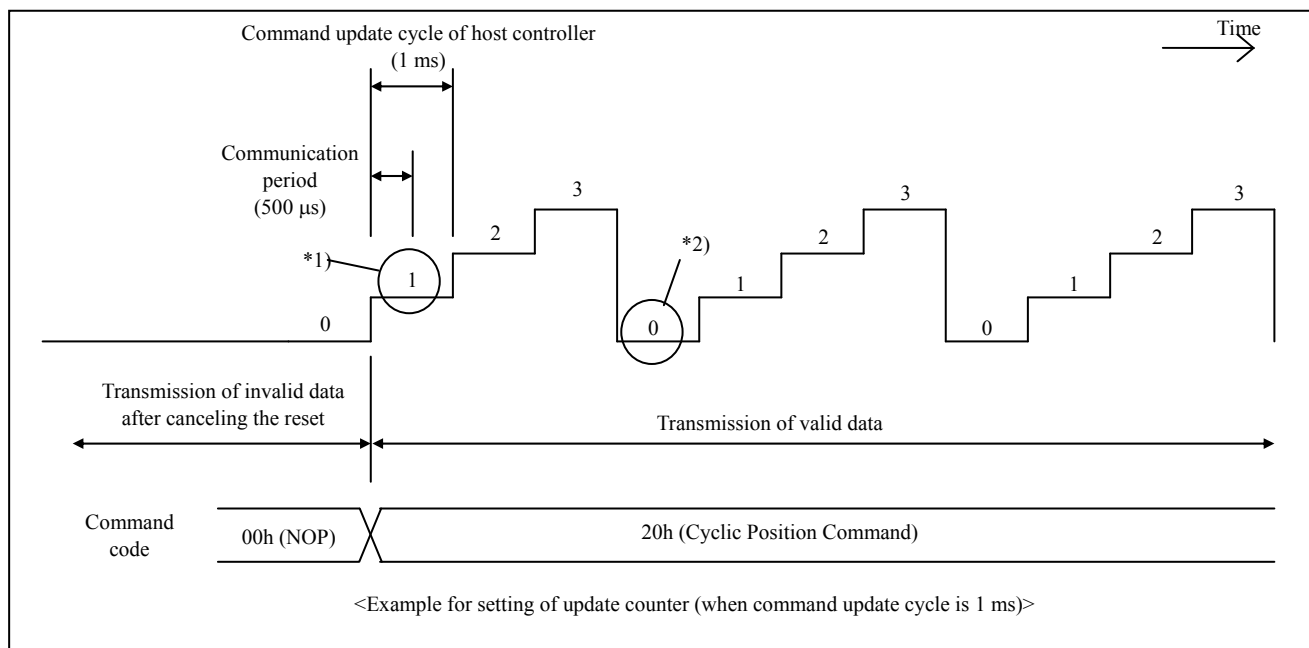

\*1) Set 1 to update counter at transmission of 1st valid data.

\*2) When the counter overflowed, repeat from 0.

## 4-2-3 Control bit (Command Bytes 2 and 3)

Byte	bit 7	bit 6	bit 5	bit 4	bit 3	bit 2	bit 1	bit 0
2	Servo_On	0	0	Gain_SW	TL_SW	Homing_Ctrl	0	0
3	Hard_Stop	Smooth_Stop	Pause	0	SL_SW	0	EX-OUT2	EX-OUT1

Title	Description
Servo_On	<ul style="list-style-type: none"> <li>Set up the Servo-ON/OFF command. 0: Servo-OFF, 1: Servo-ON</li> <li>When external servo on input (EX-SON) is assigned to interface connector (X4), the servo on command is issued as EX-SON and Servo_On are logically ANDed.</li> <li>See section 4-2-3-1 for details.</li> </ul>
Gain_SW	<ul style="list-style-type: none"> <li>Set up the gain changeover command. 0: Select 1st gain; 1: Select 2nd gain</li> <li>This signal is enabled when real-time auto tuning is disabled, 2nd gain is enabled, and gain switching through RTEX communication is enabled.</li> <li>See section 4-2-3-2 for details.</li> </ul>
TL_SW	<ul style="list-style-type: none"> <li>Set up the torque limit switching command.</li> <li>This signal is enabled when Pr.5.21 2nd torque limit is set to 3 or 4.</li> <li>See section 4-2-3-3 for details.</li> </ul>
Homing_Ctrl	<ul style="list-style-type: none"> <li>Use this to control homing operation.</li> <li>When this bit is at 1, the servo driver will detect the home reference trigger signal (e.g. Z-phase).</li> <li>This signal will be invalid except homing command.</li> <li>See section 7-2 for details.</li> </ul>
Hard_Stop	<ul style="list-style-type: none"> <li>In the profile control (PP) mode, immediately stop the internal command generation process and end the profile operation.</li> <li>See section 6-8-4 for details.</li> </ul>
Smooth_Stop	<ul style="list-style-type: none"> <li>In the profile control (PP) mode, start and continue deceleration at the preset deceleration rate to fully stop the profile operation.</li> <li>See section 6-8-4 for details.</li> </ul>
Pause	<ul style="list-style-type: none"> <li>In the profile control (PP) mode, start and continue deceleration at the preset deceleration rate to pause the profile operation.</li> <li>See section 6-8-4 for details.</li> </ul>
SL_SW	<ul style="list-style-type: none"> <li>Set up the speed limit switching command when controlling the torque (CT).</li> <li>This signal is valid when parameter Pr.3.17 Selection of speed limit is set to 1.</li> <li>See section 4-2-3-4 for details.</li> </ul>
EX-OUT2 EX-OUT1	<ul style="list-style-type: none"> <li>Select the external output signal RTEX operation output (EX-OUT1/EX-OUT2). 0: Output transistor is OFF; 1: Output transistor is ON</li> <li>This signal is enabled when RTEX operation output (EX-OUT1/EX-OUT2) is assigned to interface connector X4.</li> <li>This signal does not affect the servo control.</li> <li>See section 4-2-3-5 for details.</li> </ul>

## 4-2-3-1 Servo\_On/off command (Servo\_on)

Use this command to energize (servo on)/de-energize (servo off) the motor.

- When external servo on input (EX-SON) is assigned, the servo-on command for servo control process is enabled as both external servo on input (EX-SON) and this bit are in servo on state.

When the external servo-on input (EX-SON) is not assigned, only this bit is enabled.

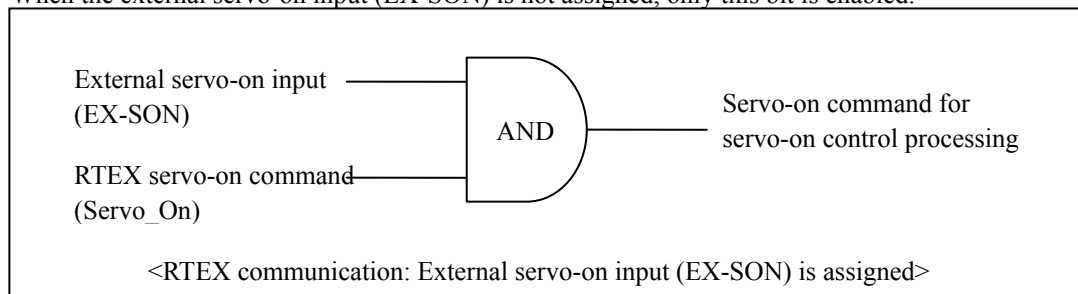

- Servo-on command cannot be used, if the servo is not ready for operation (in alarm condition or main power source is off), or motor is running (at 30 r/min or higher). Servo-ready condition can be verified by checking Byte 2, bit 6 (Servo\_Ready) in the response.
- During servo off (clearing positional deviation), the command position in the servo driver follows up the actual motor position to minimize the positional deviation to 0. Therefore, to start CP control (cyclic position control) after servo is on, re-set the coordinate system of the host controller with servo-off state, set the actual position value to the command position, and then transmit the servo-on command. For detailed description, refer to Section 7-1-1.
- When the servo is turned off while the profile position control system is operating (In\_Progress = 1), the profile process is canceled.
- During servo off, servo internal process remains position control even if cyclic command is CV/CT.

■ Instructions for use of the setup support software PANATERM

- When running “test run function” or “frequency response analyzing function (FFT)” by using the setup support software, PANATERM issues servo-on command. This command is also enabled when the external servo-on (EX-SON) is assigned. If the external servo-on (EX-SON) is not assigned, only the servo-on command from PANATERM is enabled.

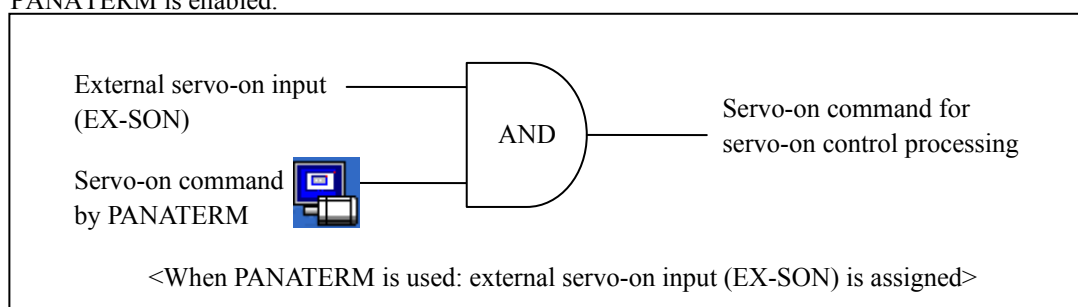

- While running “test run function” or “frequency response analyzing function (FFT)” RTEX communication cannot be used (should be previously turned off).
- Monitor value of servo-on input state on PANATERM is “servo-on command to servo control process”.

## 4-2-3-2 Gain switching command (Gain\_SW)

Class	No.	Attribute	Title	Range	Unit	Description
1	14	B	2nd gain setup	0-1	-	<p>Arrange this parameter when performing optimum adjustment by using the gain switching function.</p> <p>0: Fixed to 1st gain. Velocity loop operation is set to PI or P depending on the control bit Gain_SW of RTEX communication.</p> <p>Gain_SW = 0 -&gt; PI operation Gain_SW = 1 -&gt; P operation</p> <p>1: Enable gain switching of 1st gain (Pr.1.00-Pr.1.04) and 2nd gain (Pr.1.05-Pr.1.09).</p>

The gain can be changed by using Gain\_SW provided that the real time auto-gain tuning is disabled, 2nd gain is enabled and gain switching through RTEX communication is enabled.

0: Select 1st gain

1: Select 2nd gain

Parameter to be set up		Setting value	Description
Pr.0.02	Real-time auto-gain tuning setup	0	Disable real-time auto-gain tuning
Pr.1.14	2nd gain setup	1	Enable 1st/2nd gain switching Disable P/PI control switching
Pr.1.15	Mode of position control switching	2	Gain switching through RTEX communication (Gain_SW)
Pr.1.20	Mode of velocity control switching	2	Gain switching through RTEX communication (Gain_SW)
Pr.1.24	Mode of torque control switching	2	Gain switching through RTEX communication (Gain_SW)

Switching of velocity loop, P/PI control through Gain\_SW is possible when real-time auto-gain tuning is disabled and 2nd gain is disabled.

0: PI control (enable velocity loop integral)

1: P control (clear velocity loop integral)

Parameter to be set up		Setting value	Description
Pr.0.02	Real-time auto-gain tuning setup	0	Real-time auto-gain tuning function is disabled.
Pr.1.14	2nd gain setup	0	Enable 1st/2nd gain switching Disable P/PI control switching

## 4-2-3-3 Torque limit switching command (TL\_SW)

Torque limit can be selected from TL\_SW when Pr.5.21 Selection of torque limit setting value is 3 or 4.

Note that during torque control, the switching function is disabled and Pr.0.13 1st torque limit is enabled.

Class	No.	Attribute	Title	Range	Unit	Description																													
5	21	B	Selection of torque limit	1-4	-	<p>You can set up the torque limiting method</p> <table border="1"> <thead> <tr> <th rowspan="2">Setup value</th> <th colspan="2">TL_SW = 0</th> <th colspan="2">TL_SW = 1</th> </tr> <tr> <th>Negative direction</th> <th>Positive direction</th> <th>Negative direction</th> <th>Positive direction</th> </tr> </thead> <tbody> <tr> <td>1</td> <td colspan="4">Pr.0.13</td> </tr> <tr> <td>2</td> <td>Pr.5.22</td> <td>Pr.0.13</td> <td>Pr.5.22</td> <td>Pr.0.13</td> </tr> <tr> <td>3</td> <td colspan="2">Pr.0.13</td> <td colspan="2">Pr.5.22</td> </tr> <tr> <td>4</td> <td>Pr.5.22</td> <td>Pr.0.13</td> <td>Pr.5.26</td> <td>Pr.5.25</td> </tr> </tbody> </table> <ul style="list-style-type: none"> <li>Pr.0.13 (1st torque limit), Pr.5.22 (2nd torque limit)</li> <li>Pr.5.25 (External input positive direction torque limit), Pr.5.26 (External input negative direction torque limit)</li> </ul>	Setup value	TL_SW = 0		TL_SW = 1		Negative direction	Positive direction	Negative direction	Positive direction	1	Pr.0.13				2	Pr.5.22	Pr.0.13	Pr.5.22	Pr.0.13	3	Pr.0.13		Pr.5.22		4	Pr.5.22	Pr.0.13	Pr.5.26	Pr.5.25
						Setup value		TL_SW = 0		TL_SW = 1																									
							Negative direction	Positive direction	Negative direction	Positive direction																									
						1	Pr.0.13																												
						2	Pr.5.22	Pr.0.13	Pr.5.22	Pr.0.13																									
						3	Pr.0.13		Pr.5.22																										
4	Pr.5.22	Pr.0.13	Pr.5.26	Pr.5.25																															

## 4-2-3-4 Speed limit switching command (SL\_SW)

When the setting value of Pr.3.17 Selection of speed limit is 1, the speed limit value during torque controlling can be selected from SL\_SW.

Class	No.	Attribute	Title	Range	Unit	Description									
3	17	B	Selection of speed limit	0-1	-	<p>Set the speed limit value selection method for torque controlling.</p> <table border="1"> <thead> <tr> <th>Setup value</th> <th>SL_SW = 0</th> <th>SL_SW = 1</th> </tr> </thead> <tbody> <tr> <td>0</td> <td colspan="2">Pr.3.21</td> </tr> <tr> <td>1</td> <td>Pr.3.21</td> <td>Pr.3.22</td> </tr> </tbody> </table>	Setup value	SL_SW = 0	SL_SW = 1	0	Pr.3.21		1	Pr.3.21	Pr.3.22
						Setup value	SL_SW = 0	SL_SW = 1							
						0	Pr.3.21								
1	Pr.3.21	Pr.3.22													
3	21	B	Speed limit value 1	0-20000	r/min	<p>Set the speed limit value for torque controlling.</p> <p>During torque controlling, the speed set by the speed limit value will not be exceeded.</p> <p>The internal value is limited by the setting of Pr.5.13 or the motor max. speed <math>\times</math> 1.2, whichever low.</p>									
						<p>When Pr.3.17 Selection of speed limit = 1, set the speed limit value as specified by SL_SW = 1.</p> <p>The internal value is limited by the setting of Pr.5.13 or the motor max. speed <math>\times</math> 1.2, whichever low.</p>									
3	22	B	Speed limit value 2	0-20000	r/min	<p>When Pr.3.17 Selection of speed limit = 1, set the speed limit value as specified by SL_SW = 1.</p> <p>The internal value is limited by the setting of Pr.5.13 or the motor max. speed <math>\times</math> 1.2, whichever low.</p>									

## 4-2-3-5 External output signal operation instruction (EX-OUT 1/2)

The external output signal S01 and S02 from the interface connector (X4) can be controlled by assigning RTEX operation output 1 (EX-OUT 1) and RTEX operation output 2 (EX-OUT 2) to these signals.

State of the output transistor of RTEX operation output 1 (2) is as shown below: after establishment of RTEX, before establishment of RTEX communication after resetting and shutoff after establishment of RTEX. Note that control bit cannot be used for controlling through RTEX communication if RTEX communication is not established after resetting or if shutoff occurs after establishment of RTEX. Safety of the system should be taken into consideration when setting the system.

Class	No.	Attribute	Title	Range	Unit	Description
7	24	C	RTEX function expansion setup 3	-32768 -32767	-	bit0: Setup EX-OUT 1 output state during communication cutoff after establishment of RTEX communication. 0: Hold 1: Initialize (output when EX-OUT 1 = 0)  bit1: Setup EX-OUT 2 output state during communication cutoff after establishment of RTEX communication. 0: Hold 1: Initialize (output when EX-OUT 2 = 0)

Signal	Symbol	Pr.7.24 RTEX function expansion setup 3	RTEX control bit	State of output transistor		
				Communication established	Reset	Communication blocked
RTEX operation output 1	EX-OUT1	bit0 = 0 (Hold)	EX-OUT1 = 0	OFF	OFF	Hold
			EX-OUT1 = 1	ON		
		bit0 = 1 (Initialize)	EX-OUT1 = 0	OFF	OFF	OFF
			EX-OUT1 = 1	ON		
RTEX operation output 2	EX-OUT2	bit1 = 0 (Hold)	EX-OUT2 = 0	OFF	OFF	Hold
			EX-OUT2 = 1	ON		
		bit1 = 1 (Initialize)	EX-OUT2 = 0	OFF	OFF	OFF
			EX-OUT2 = 1	ON		



## 4-3 Data block in response (16-byte/32-byte)

Response will be transmitted from the slave (servo driver) to the master (host controller).

Byte	bit 7	bit 6	bit 5	bit 4	bit 3	bit 2	bit 1	bit 0
0	C/R(1)	Update_Counter_Echo		Actual_MAC-ID (0-31)				
1	CMD_Error	Command_Code_Echo						
2	Servo_Active	Servo_Ready	Alarm	Warning	Torque_Limited	Homing_Complete	In_Progress	In_Position
3	E-STOP	SI-MON4 /EX-SON	SI-MON3 /EXT3	SI-MON2 /EXT2	SI-MON1 /EXT1	HOME	POT /NOT	NOT /POT
4	Response_Data1							L
5								ML
6								MH
7								H
8	Response_Data2							L
9								ML
10								MH
11								H
12	Response_Data3							L
13								ML
14								MH
15								H

- Notes:
- Command code at command data block defines the contents from byte 4 to byte 15.
  - Disposition of multiple byte data is little endian, which means that lower byte is first.
  - Replies 0 at unused bits.

## 4-3-1 Command\_Code\_Echo and Response\_Data (Response byte 1, 4 to 15)

Byte	bit 7	bit 6	bit 5	bit 4	bit 3	bit 2	bit 1	bit 0
1	CMD_Error	Command_Code_Echo						
4-7	Response_Data1							
8-11	Response_Data2							
12-15	Response_Data3							

Title	Description
CMD_Error	<ul style="list-style-type: none"> <li>Return 1 at the command error occurred.</li> <li>Set to 1 when an error occurs upon receiving the command (before processing it).</li> </ul>
Command_Code_Echo	<ul style="list-style-type: none"> <li>Return the echo-back value of command code.</li> </ul>
Response_Data1	<ul style="list-style-type: none"> <li>Return the monitor data specified by Pr.7.29 RTEX monitor select 1.</li> <li>Specify the monitor data by setting monitor command New Type_Code (8-bit) to Pr.7.29.</li> <li>For New Type_Code details, refer to clause 6-9-1.</li> <li>When Pr.7.29 = 0, actual position (New Type_Code = 07h) is returned as compatibility with MINAS-A4N.</li> <li>Arrangement of byte data is little endian, which means that lower byte is first.</li> </ul>
Response_Data2	<ul style="list-style-type: none"> <li>Return the response data specified by non-cyclic command code.</li> <li>When non-cyclic command code is 0h (normal command), returns the monitor data specified in Pr.7.30 RTEX monitor select 2.</li> <li>Specify the monitor data by setting monitor command New Type_Code (8-bit) to Pr.7.30.</li> <li>For New Type_Code details, refer to clause 6-9-1.</li> <li>When Pr.7.30 = 0, actual speed (New Type_Code = 05h) is returned as compatibility with MINAS-A4N.</li> <li>Arrangement of byte data is little endian, which means that lower byte is first.</li> </ul>
Response_Data3	<ul style="list-style-type: none"> <li>Return the response data specified by non-cyclic command code.</li> <li>When non-cyclic command code is 0h (normal command), returns the monitor data specified in Pr.7.31 RTEX monitor select 3.</li> <li>Specify the monitor data by setting monitor command New Type_Code (8-bit) to Pr.7.31.</li> <li>For New Type_Code details, refer to clause 6-9-1.</li> <li>When Pr.7.31 = 0, torque (New Type_Code = 06h) is returned as compatibility with MINAS-A4N.</li> <li>Arrangement of byte data is little endian, which means that lower byte is first.</li> </ul>

## 4-3-2 Response header (Response byte 0)

Byte	bit 7	bit 6	bit 5	bit 4	bit 3	bit 2	bit 1	bit 0
0	C/R(1)	Update_Counter_Echo	Actual_MAC-ID (0-31)					

Title	Description
C/R	<ul style="list-style-type: none"> <li>C/R bit distinguish command and response.</li> <li>Return 1 as a response.</li> </ul>
Update_Counter_Echo	<ul style="list-style-type: none"> <li>Return the echo-back value of Update_Counter.</li> <li>Use this to check whether the drive has received properly.</li> </ul>
Actual_MAC-ID	<ul style="list-style-type: none"> <li>Return the node address of the servo driver.</li> <li>This is not echo-back, but actual value that is the setup of the RSW at power-up.</li> </ul>

## 4-3-3 Status flag (Response byte 2)

Byte	bit 7	bit 6	bit 5	bit 4	bit 3	bit 2	bit 1	bit 0
2	Servo_Active	Servo_Ready	Alarm	Warning	Torque_Limited	Homing_Complete	In_Progress /AC_OFF	In_Position

Title	Description											
Servo_Active	<ul style="list-style-type: none"> <li>Return 1 at Servo-ON state (motor energized).</li> <li>Also becomes servo-off state during deceleration with dynamic brake.</li> </ul>											
Servo_Ready	<ul style="list-style-type: none"> <li>Return 1 at Servo-Ready (transitionable to Servo-ON) state.</li> <li>Becomes 1 when all of the 3 conditions are satisfied, “Main power established”, “No alarm occurrence” and “Synchronization between the servo and the communication established”. For details, refer to Section 4-3-3-1.</li> </ul>											
Alarm	<ul style="list-style-type: none"> <li>Return 1 at alarm occurrence</li> </ul>											
Warning	<ul style="list-style-type: none"> <li>Return 1 at warning occurrence</li> <li>Determine whether to latch the warning state by the setting of Pr.6.27 Warning latch state setup. For details, refer to technical reference, SX-DSV02202”Section 7-3”, Functional Specification.</li> </ul>											
Torque_Limited	<ul style="list-style-type: none"> <li>Return 1 at torque limited.</li> <li>Set to 1 when the internal torque command is limited by a parameter, etc.</li> <li>Output condition during torque control can be set by Pr.7.0 3 Setting output during torque limit. For details, refer to technical reference, SX-DSV02202”Section 6-1”, Functional Specification.</li> </ul>											
Homing_Complete	<ul style="list-style-type: none"> <li>Return 1 at homing operation completed and holds 1 after that (secure home position).</li> <li>Clears to 0 at reception of homing command.</li> <li>Set at 1 when in the absolute mode (using absolute encoder with absolute, or using external scale in full-closed control mode with absolute), because the home position is determined upon turning on of control power: set at 0 in the incremental mode.</li> <li>As with in the case of turning on of the control power, the position information and this bit are also initialized as the reset command (□1h) is executed.</li> <li>When the control power is turned on after executing “Trial run function”, “Frequency response analyzing function (FFT function)” or “Absolute encoder multi-turn clear” from the setup support software PANATERM, the value is initialized to the value that will be obtained by executing the reset command, but the state of this bit remains unchanged. Repeat the homing process (reset control power when absolute clear has been done).</li> </ul>											
In_Progress /AC_OFF	<ul style="list-style-type: none"> <li>During setting of In_Progress and in profile position control (PP) mode, returns 1 while internal command position is being generated, and returns 0 upon completion of the internal command position generation (transfer out).</li> <li>Return 1 upon occurrence of main power off alarm during AC_OFF setting. For the read signal selection method, see 4-3-3-2.</li> </ul>											
In_Position	<ul style="list-style-type: none"> <li>The function of flag depends on the control mode as shown below. *1</li> </ul> <table border="1"> <thead> <tr> <th>Function</th> <th>Control mode</th> <th>Description</th> </tr> </thead> <tbody> <tr> <td rowspan="2">Positioning complete</td> <td>Position control (CP, PP)</td> <td> <ul style="list-style-type: none"> <li>Return 1 upon completion of homing.</li> <li>As with for positioning complete output (INP, external output signal), set the output condition through parameters Pr.4.31 Positioning complete range, Pr.4.32 Positioning complete output setup and Pr.4.33 INP hold time. For details, refer to Technical Reference, SX-DSV02202”Section 4-2-4”, Functional Specification.</li> </ul> </td> </tr> <tr> <td>Velocity control (CV)</td> <td> <ul style="list-style-type: none"> <li>Return 1 when the motor actual speed and command velocity are the same.</li> <li>As with for the speed coincidence output (V-COIN) (external output signal), set the output condition through Pr.4.35 Speed coincidence range. For details, refer to Technical Reference, SX-DSV02202”Section 4-3-2”, Functional Specification.</li> </ul> </td> </tr> <tr> <td></td> <td>Torque control (CT)</td> <td> <ul style="list-style-type: none"> <li>Return 1 when the motor actual speed and <u>the speed limit value</u> are the same.</li> <li>Set the output condition through Pr.4.35 Speed coincidence range. For details, refer to Technical Reference, SX-DSV02202”Section 4-3-2”, Functional Specification.</li> </ul> </td> </tr> </tbody> </table>	Function	Control mode	Description	Positioning complete	Position control (CP, PP)	<ul style="list-style-type: none"> <li>Return 1 upon completion of homing.</li> <li>As with for positioning complete output (INP, external output signal), set the output condition through parameters Pr.4.31 Positioning complete range, Pr.4.32 Positioning complete output setup and Pr.4.33 INP hold time. For details, refer to Technical Reference, SX-DSV02202”Section 4-2-4”, Functional Specification.</li> </ul>	Velocity control (CV)	<ul style="list-style-type: none"> <li>Return 1 when the motor actual speed and command velocity are the same.</li> <li>As with for the speed coincidence output (V-COIN) (external output signal), set the output condition through Pr.4.35 Speed coincidence range. For details, refer to Technical Reference, SX-DSV02202”Section 4-3-2”, Functional Specification.</li> </ul>		Torque control (CT)	<ul style="list-style-type: none"> <li>Return 1 when the motor actual speed and <u>the speed limit value</u> are the same.</li> <li>Set the output condition through Pr.4.35 Speed coincidence range. For details, refer to Technical Reference, SX-DSV02202”Section 4-3-2”, Functional Specification.</li> </ul>
Function	Control mode	Description										
Positioning complete	Position control (CP, PP)	<ul style="list-style-type: none"> <li>Return 1 upon completion of homing.</li> <li>As with for positioning complete output (INP, external output signal), set the output condition through parameters Pr.4.31 Positioning complete range, Pr.4.32 Positioning complete output setup and Pr.4.33 INP hold time. For details, refer to Technical Reference, SX-DSV02202”Section 4-2-4”, Functional Specification.</li> </ul>										
	Velocity control (CV)	<ul style="list-style-type: none"> <li>Return 1 when the motor actual speed and command velocity are the same.</li> <li>As with for the speed coincidence output (V-COIN) (external output signal), set the output condition through Pr.4.35 Speed coincidence range. For details, refer to Technical Reference, SX-DSV02202”Section 4-3-2”, Functional Specification.</li> </ul>										
	Torque control (CT)	<ul style="list-style-type: none"> <li>Return 1 when the motor actual speed and <u>the speed limit value</u> are the same.</li> <li>Set the output condition through Pr.4.35 Speed coincidence range. For details, refer to Technical Reference, SX-DSV02202”Section 4-3-2”, Functional Specification.</li> </ul>										

- \*1 When an electronic gear ratio is larger than 1/1, even if it is servo-off, the remainder on operation may occur and a feedback scale position deviation may not be set to 0. If it sets up per feedback scale by Pr5.20 " Position setup unit select ", output of positioning complete 1/2 (INP/INP2) signals may turn off during servo-off. For details, refer to Technical Reference, SX-DSV02202"Section 4-2-4,9-1", Functional Specification.

#### 4-3-3-1 Servo Ready state (Servo\_Ready)

Return 1 at Servo-Ready (transitionable to Servo-ON) state.

- Becomes 1 when all of the 3 conditions are satisfied, "Main power established", "No alarm occurrence" and "Synchronization between the servo and the communication".

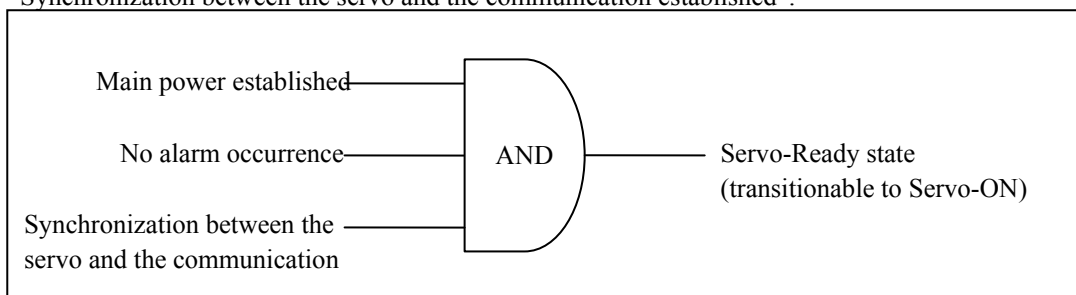

- If the ratio of communication cycle and command updating cycle is not 1:1, in the inter-axis semi- synchronous mode (Pr.7.22 bit 1 = 0), or if TMG\_CNT is not correctly counted up in the inter-axis full-synchronous mode (Pr.7.22 bit 1 = 1), servo-ready state is not possible.
- As an exceptional processing, during processing of reset command, in attribute C parameter validation mode, the value is left undefined.

#### 4-3-3-2 Internal position command generation state (In\_Progress)/main power off alarm state (AC\_OFF)

Using bit 8 of Pr.7.23 RTEX function expansion setup 2, select the signal to which bit 1 of status flag is to be assigned.

Class	No.	Attribute	Title	Range	Unit	Description
7	23	B	RTEX function expansion setup 2	-32768 -32767	-	[bit 8] RTEX status select by In_Progress/AC_OFF 0: In_Progress, 1: AC_OFF  ▪ For description on other bits, refer to Technical reference, SX-DSV02202"Section 9-1", Functional Specification.

## 4-3-4 Input signal status flag (Response byte 3)

Byte3 at Response is the status area of the external input signal from the interface connector, (X4).

Byte	bit 7	bit 6	bit 5	bit 4	bit 3	bit 2	bit 1	bit 0
3	SI-MON5 /E-STOP	SI-MON4 /EX-SON	SI-MON3 /EXT3	SI-MON2 /EXT2	SI-MON1 /EXT1	HOME	POT /NOT	NOT /POT

- On MINAS-A5N, 8 external input connection terminals are provided to which functions and logics may be assigned individually. For details, refer to Technical Reference, SX-DSV02202"Section 9-1", Functional Specification.
- When function is not assigned to a terminal, corresponding bit in this status flag is set to 0.  
A terminal can be assigned with 2 or more functions, but only 1 per control mode. However, this is confusion because some functions are enabled and some are disabled upon changing control modes: Ideally, functions allocated to a terminal should be common to all control modes.
- Because the following pair of designations are assigned to the same bit position, only one of designations can be selected: SI-MON1/EXT1, SI-MON2/EXT2, SI-MON3/EXT3, SI-MON4/EX-SON and SI-MON5/E-STOP. If attempt is made to allocate 2 or more functions to the same bit, Err.33.0 (I/F input multiple allocation error 1 protect) or Err.33.1 (I/F input multiple allocation error 2 protect) will be enabled.
- This status returns the logical status (1: function active) but not physical status (input transistor ON/OFF state). However, status of driver inhibit input (POT/NOT) can be logically set.
- EXT1, EXT2 and EXT3 indicate the state of input signal but not complete state of latch.
- For driver inhibit input (POT/NOT), status response condition, status bit arrangement and status logic can be set as shown below while the function is disabled (Pr.5.04 = 1), through the parameter Pr.7.23 RTEX function extended setup 2.  
Because CCWL and CWL used on MINAS-A4N series are changed to POT and NOT, respectively, on MINAS-A5N series, correctly set this parameter and Pr.0.00 Rotating direction setup to make the functions effective on MINAS-A4N.

Class	No.	Attribute	Title	Range	Unit	Description
7	23	B	RTEX function extended setup 2	-32768 -32767	-	<p>[bit 2] Set RTEX status response condition when POT/NOT function is disabled Pr.5.04 = 1. 0: Enable in terms of RTEX status (response) 1: Disable in terms of RTEX status (not response = normally 0)</p> <p>[bit 3] POT/NOT RTEX status bit arrangement set up 0: POT at bit 1; NOT at bit 0 1: NOT at bit 1; POT at bit 0</p> <p>[bit 6] POT/NOT RTEX status logic set up 0: No inversion (active 1) 1: Inversion (active 0)</p> <p>▪ For description on other bits, refer to Technical reference, SX-DSV02202"Section 9-1", Functional Specification.</p>

- Noise filtering process is performed when capturing the input signals within the servo driver, and this causes some detection delay. Total delay time including the transmission delay in communication will be several ms. If this delay time gives inconvenience, provide the system that directly connects the sensor signal to host controller.

## 4-4 Command data block of sub-command (only for 32-byte mode)

Sub-command is transferred from the master (host controller) to the slave (servo driver).

Byte	bit7	bit6	bit5	bit4	bit3	bit2	bit1	bit0
16	Sub_Chk	0	0	0	Sub_Command_Code			
17	Sub_Type_Code							
18	Sub_Index							
19								
20	Sub_Command_Data1							L
21								ML
22								MH
23								H
24	Sub_Command_Data2							L
25								ML
26								MH
27								H
28	Sub_Command_Data3							L
29								ML
30								MH
31								H

- Notes:
- Specify the arrangement of Byte 17 to Byte 23 by using Byte 16 sub-command codes.
  - Arrangement of data bytes is little endian which means that lower byte is first.
  - Set unused bit to 0.

## 4-4-1 Sub-command code and sub-command argument (Command bytes 16 to 31)

Byte	bit7	bit6	bit5	bit4	bit3	bit2	bit1	bit0
16	Sub_Chk	0	0	0	Sub_Command_Code			
17	Sub_Type_Code							
18-19	Sub_Index							
20-23	Sub_Command_Data1							
24-27	Sub_Command_Data2							
28-31	Sub_Command_Data3							

Title	Description								
Sub_Chk	<ul style="list-style-type: none"> <li>Used to check whether a sub-command frame or not.</li> <li>Be sure to set to 1.</li> <li>If this bit is 0 in the 32-byte mode, Err.86.0 (RTEX cyclic data error protection 1) will occur.</li> </ul>								
Sub_Command_Code	<ul style="list-style-type: none"> <li>Used to set sub-command code.</li> <li>Fundamental function is the same as that of equivalent non-cyclic command.</li> </ul> <p>Below shows corresponding non-cyclic command (sub-command).</p> <table border="1"> <thead> <tr> <th>Sub-command code</th> <th>Name of sub-command</th> </tr> </thead> <tbody> <tr> <td>0h</td> <td>Normally</td> </tr> <tr> <td>2h</td> <td>System ID</td> </tr> <tr> <td>Ah</td> <td>Monitor</td> </tr> </tbody> </table>	Sub-command code	Name of sub-command	0h	Normally	2h	System ID	Ah	Monitor
Sub-command code	Name of sub-command								
0h	Normally								
2h	System ID								
Ah	Monitor								
Sub_Type_Code	<ul style="list-style-type: none"> <li>Set the command data to be specified by sub-command code.</li> </ul>								
Sub_Index	<ul style="list-style-type: none"> <li>Set the command data to be specified by sub-command code.</li> </ul>								
Sub_Command_Data1	<ul style="list-style-type: none"> <li>Set the command data to be specified by sub-command code.</li> </ul>								
Sub_Command_Data2	<ul style="list-style-type: none"> <li>Set the data (Feed forward data) selected through Pr.7.36 RTEX command setup 2. See 7-7 for details.</li> </ul>								
Sub_Command_Data3	<ul style="list-style-type: none"> <li>Set the data (Feed forward data) selected through Pr.7.37 RTEX command setup 3. See 7-7 for details.</li> </ul>								

For details of the sub-commands, refer to Chapter 6.

## 4-5 Response data block of sub-command (only for 32-byte mode)

Response of sub-command is transferred from the slave (servo driver) to master (host controller).

Byte	bit7	bit6	bit5	bit4	bit3	bit2	bit1	bit0	
16	Sub_CMD_Err	Sub_ERR	Sub_WNG	Sub_Busy	Sub_Command_Code_Echo				
17	Sub_Type Code Echo								
18	Sub_Index_Echo								
19									
20	Sub_Response_Data1								L
21									ML
22									MH
23									H
24	Sub_Response_Data2								L
25									ML
26									MH
27									H
28	Sub_Response_Data3								L
29									ML
30									MH
31									H

- Notes:
- Specify the arrangement of Byte 17 to Byte 23 by using Byte 16 sub-command codes.
  - Arrangement of data bytes is little endian which means that lower byte is first.



## 4-5-1 Sub-command code echo and response data (Command bytes 16 to 31)

Byte	bit7	bit6	bit5	bit4	bit3	bit2	bit1	bit0
16	Sub_CMD_Err	Sub_ERR	Sub_WNG	Sub_Busy	Sub_Command_Code_Echo			
17	Sub_Type_Code_Echo							
18-19	Sub_Index_Echo							
20-23	Sub_Response_Data1							
24-27	Sub_Response_Data2							
28-31	Sub_Response_Data3							

Title	Description
Sub_CMD_Err	<ul style="list-style-type: none"> <li>Return 1 upon sub-command error.</li> <li>Set this bit to 1 when error occurs upon receiving the sub-command (before executing it).</li> </ul>
Sub_ERR	<ul style="list-style-type: none"> <li>Indicates the state of the sub-command error.</li> <li>Set this bit to 1 when error occurs while processing after receiving the sub-command.</li> </ul>
Sub_WNG	<ul style="list-style-type: none"> <li>Indicates the state of the sub-command error.</li> <li>Set this bit to 1 when problem is found after processing the command.</li> </ul>
Sub_Busy	<ul style="list-style-type: none"> <li>Indicates the state of the sub-command error.</li> <li>Remain this bit at 1 while processing the command.</li> </ul>
Sub_Command_Code_Echo	<ul style="list-style-type: none"> <li>Return echo back value of Sub_Command_Code.</li> </ul>
Sub_Type_Code_Echo	<ul style="list-style-type: none"> <li>Return echo back value of Sub_Type_Code.</li> </ul>
Sub_Index_Echo	<ul style="list-style-type: none"> <li>Return echo back value of Sub_Index.</li> </ul>
Sub_Response_Data1	<ul style="list-style-type: none"> <li>Return the response data specified by sub command code.</li> <li>Return the monitor data specified through Pr.7.32 RTEX monitor select 4 when the sub-command code is 0h (normal command). Specify the monitor data by setting monitor command Type_Code for A5N (8 bits) to Pr.7.32. For details, refer to 6-9-1.</li> <li>Return 0 when Pr.7.32 = 0.</li> <li>Arrangement of data bytes is little endian which means that lower byte is first.</li> </ul>
Sub_Response_Data2	<ul style="list-style-type: none"> <li>Return the monitor data specified by Pr.7.33 RTEX monitor select 5. Specify the monitor data by setting monitor command Type_Code for A5N (8 bits) to Pr.7.33. For details, refer to 6-9-1.</li> <li>Return 0 when Pr.7.33 = 0.</li> <li>Arrangement of data bytes is little endian which means that lower byte is first.</li> </ul>
Sub_Response_Data3	<ul style="list-style-type: none"> <li>Return the monitor data specified by Pr.7.34 RTEX monitor select 6. Specify the monitor data by setting monitor command Type_Code for A5N (8 bits) to Pr.7.34. For details, refer to 6-9-1.</li> <li>Return 0 when Pr.7.34 = 0.</li> <li>Arrangement of data bytes is little endian which means that lower byte is first.</li> </ul>

## 5. Cyclic Command Description

### 5-1 Cyclic command list [Under review]

Cyclic command requires no transfer procedure. That is, when received, it directly reflects on the control. The cyclic command selects the control mode in the servo driver.

Only position control is accommodated in the full-closed control mode. If speed control (CV) or torque control (CT) is received in full-closed control mode, it causes command error.

For relationship between the control mode and communication cycle/command updating cycle, refer to Section 2-5.

Control mode	Abbreviation	Command _Code	Description
NOP	NOP	00h	For temporary transmission of invalid data immediately after establishment of the network. Never use this command for any other purpose. Upon receiving this command, control is performed based on the previously received command.
Profile Position Mode	PP	1□h	In this control mode, the target position, target speed and acceleration/deceleration speed (parameters) are specified and the position command is generated in the servo driver.
Cyclic Position Mode	CP	2□h	In this mode, the host controller generates the position command and updates it (or transmits updated command) at the command updating cycle.
Cyclic Velocity Mode	CV	3□h	In this mode, the host controller generates the velocity command and updates it (or transmits updated command) at the communication cycle.
Cyclic Torque Mode	CT	4□h	In this mode, the host controller generates the torque command and updates it (or transmits updated command) at the communication cycle.

## 5-2 NOP command (Command code: 0□h)

This is for the temporary transmission of invalid data after the network has been established.  
Never use this command for any other purpose.

The servo driver will control based on the previous command.  
Control bits (Byte 2–3) are also invalid (previous data is retained).

If NOP command is transmitted in servo-on state, the control bit is disabled, inhibiting servo off.

	Byte	Command								Byte	Response									
		bit7	6	5	4	3	2	1	0		bit7	6	5	4	3	2	1	0		
Cyclic	0	C (0)	Update_Counter		MAC-ID					0	R (1)	Update_Counter Echo		Actual_MAC-ID						
	1	TMG_ CNT	Command_Code (00h)								1	CMD_ Error	Command_Code_Echo (00h)							
	2	Optional								2	Status_Flags									
	3									3										
	4	<Command_Data1> Optional								L	4	<Response_Data1> Default: Actual_Position (APOS) [Command unit]								L
	5									ML	5									ML
	6									MH	6									MH
7	H									7	H									
Non-cyclic	8	<Command_Data2> Optional								L	8	<Response_Data2> Default: Actual_Speed (ASPD) [Command unit/s] or [r/min]								L
	9									ML	9									ML
	10									MH	10									MH
	11									H	11									H
	12	<Command_Data3> Optional								L	12	<Response_Data3> Default: Torque (TRQ) [0.1%]								L
	13									ML	13									ML
	14									MH	14									MH
15	H									15	H									

Title	Command	Response						
<Response_Data1> Actual_Position (APOS)	–	Default: Motor actual position [Size]: Signed 32-bit [Unit]: Command unit						
<Response_Data2> Actual_Speed (ASPD)	–	Default: Motor actual speed [Size]: Signed 32-bit [Unit]: Setting value of Pr.7.25 RTEX speed unit setup <table border="1" style="margin-left: auto; margin-right: auto;"> <thead> <tr> <th>Pr.7.25</th> <th>Unit</th> </tr> </thead> <tbody> <tr> <td>0</td> <td>[r/min]</td> </tr> <tr> <td>1</td> <td>[Command unit/s]</td> </tr> </tbody> </table>	Pr.7.25	Unit	0	[r/min]	1	[Command unit/s]
Pr.7.25	Unit							
0	[r/min]							
1	[Command unit/s]							
<Response_Data3> Torque (TRQ)	–	Default: Instruction torque to motor [Size]: Signed 32-bit [Unit]: 0.1%						

- For selection method of Response\_Data 1/2/3, see 4-3-1.

### 5-3 Profile position control (PP) command (Command code: 1□h)

In this position control mode, the target position, target speed and acceleration/deceleration speed are specified and the servo driver internally generates the position command.

Upon receiving this command, the servo driver switches the internal control mode to the position control. For detailed block diagram of the position control, refer to Technical Reference, SX-DSV02202”Section 5-2-1”, Functional Specification.

When in the full-closed control mode, position control is performed using the external scale.

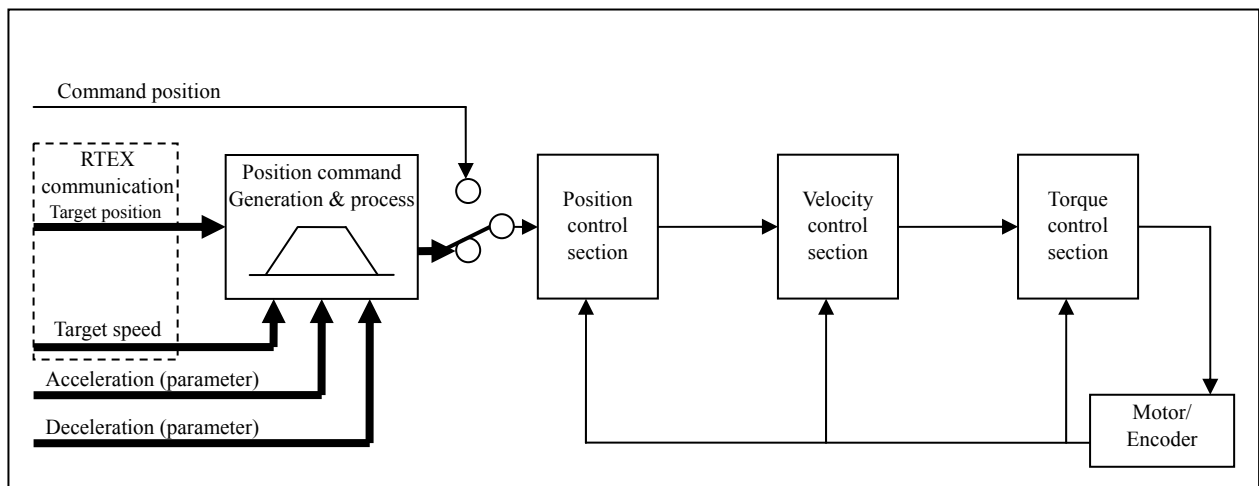

	Byte	Command								Byte	Response																
		bit7	6	5	4	3	2	1	0		bit7	6	5	4	3	2	1	0									
Cyclic	0	C (0)	Update_Counter		MAC-ID				0	R (1)	Update_Counter Echo		Actual_MAC-ID														
	1	TMG_CNT	Command_Code (1□h)								1	CMD_Error	Command_Code_Echo (1□h)														
	2	Control_Bits								2	Status_Flags																
	3									3																	
	4	<Command_Data1> Target_Position (TPOS) [Command unit]								L	4	<Response_Data1> Default: Actual_Position (APOS) [Command unit]															
	5									ML	5																
	6									MH	6																
7	H									7																	
Non-cyclic	8	<Command_Data2> Dependent on non-cyclic command								L	8	<Response_Data2> Dependent on non-cyclic command															
	9									ML	9																
	10									MH	10																
	11									H	11																
	12									L	12									<Response_Data3> Dependent on non-cyclic command							
	13									ML	13																
	14									MH	14																
15	H	15																									

Title	Command	Response
<Command_Data1> Target_Position (TPOS)	Target position (absolute position) [Size]: Signed 32-bit [Unit]: Instruction unit [Setting range]: 8000000h-7FFFFFFh (-2147483648 to 2147483647)	-
<Response_Data1> Actual_Position (APOS)	-	Default: Actual position of motor [Size]: Signed 32-bit [Unit]: Instruction unit

- For selection method of Response\_Data 1, see 4-3-1.

### 5-4 Cyclic position control (CP) command (Command code: 2□h)

In this position control mode, the host controller generates the position command and updates it (or transmits updated command) at the command updating cycle.

Upon receiving this command, the servo driver switches the internal control mode to the position control. For detailed block diagram of the position control, refer to Technical Reference, SX-DSV02202”Section 5-2-1”, Functional Specification.

When in the full-closed control mode, position control is performed using the external scale.

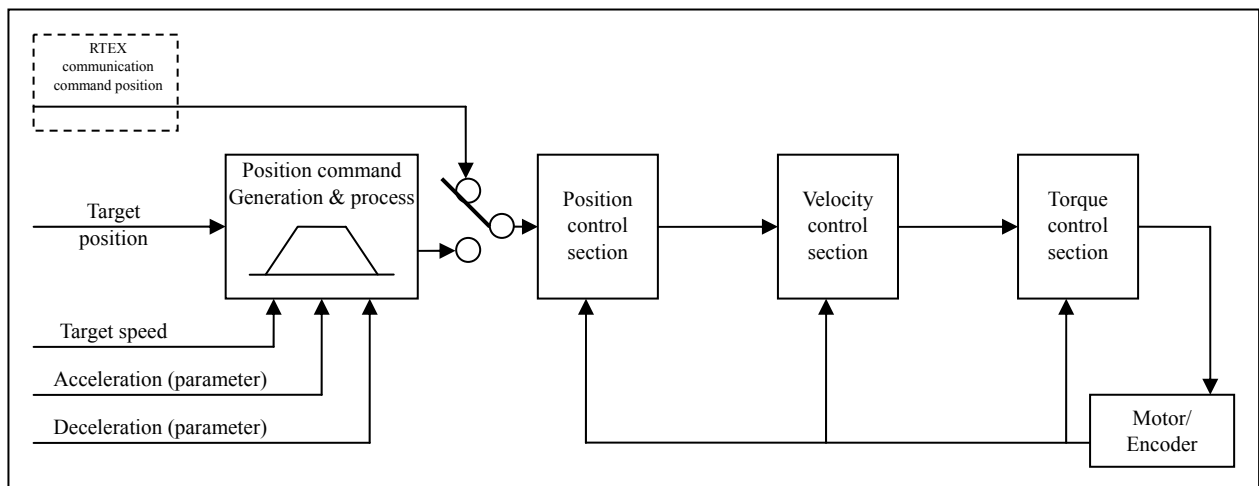

	Byte	Command								Byte	Response																
		bit7	6	5	4	3	2	1	0		bit7	6	5	4	3	2	1	0									
Cyclic	0	C (0)	Update_Counter		MAC-ID						0	R (1)	Update_Counter Echo		Actual_MAC-ID												
	1	TMG_CNT	Command_Code (2□h)								1	CMD_Error	Command_Code_Echo (2□h)														
	2	Control_Bits								2	Status_Flags																
	3									3																	
	4	<Command_Data1> Target_Position (CMD_POS) [Command unit]								L	4	<Response_Data1> Default: Actual_Position (APOS) [Command unit]															
	5									ML	5																
	6									MH	6																
7	H									7																	
Non-cyclic	8	<Command_Data2> Dependent on non-cyclic command								L	8	<Response_Data2> Dependent on non-cyclic command															
	9									ML	9																
	10									MH	10																
	11									H	11																
	12									L	12									<Response_Data3> Dependent on non-cyclic command							
	13									ML	13																
	14									MH	14																
15	H	15																									

Title	Command	Response
<Command_Data1> Target_Position (TPOS)	Target position (absolute position) [Size]: Signed 32-bit [Unit]: Instruction unit [Setting range]: 80000000h-7FFFFFFFh (-2147483648 to 2147483647)	-
<Response_Data1> Actual_Position (APOS)	-	Default: Actual position of motor [Size]: Signed 32-bit [Unit]: Instruction unit

- For selection method of Response\_Data 1, see 4-3-1.

5-5 Cyclic velocity control (CV) command (Command code: 3□h)

In this velocity control mode, the host controller generates the command velocity and updates it (or transmits updated command) at the communication cycle.

Upon receiving this command, the servo driver switches the internal control mode to velocity control.

For details of velocity control block diagram, refer to Technical Reference, SX-DSV02202”Section 5-2-2”, Functional Specification.

Receiving this command in the full-closed control mode causes a command error.

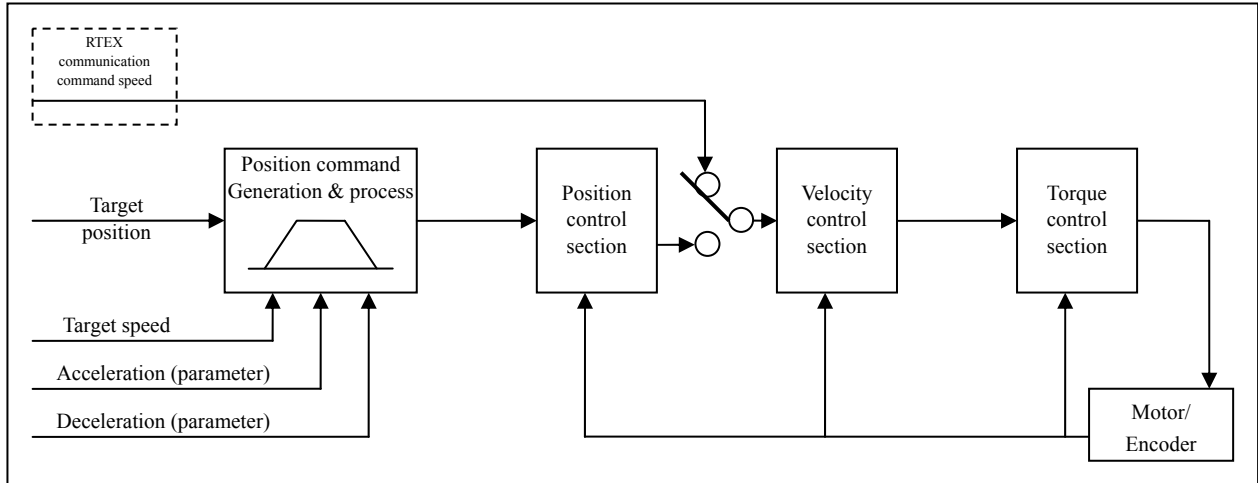

	Byte	Command								Byte	Response									
		bit7	6	5	4	3	2	1	0		bit7	6	5	4	3	2	1	0		
Cyclic	0	C (0)	Update_Counter		MAC-ID						0	R (1)	Update_Counter_Echo		Actual_MAC-ID					
	1	TMG_CNT	Command_Code (3□h)								1	CMD_Error	Command_Code_Echo (3□h)							
	2	Control_Bits								2	Status_Flags									
	3									3										
	4	<Command_Data1>								L	<Response_Data1>								L	
	5	Target_Position (CSPD)								ML	Default: Actual_Position (APOS)								ML	
	6	[Command unit/s] or [r/min]								MH	[Command unit]								MH	
Non-cyclic	7									H									H	
	8	<Command_Data2>								L	<Response_Data2>								L	
	9	Dependent on non-cyclic command								ML	Dependent on non-cyclic command								ML	
	10									MH									MH	
	11									H									H	
	12	<Command_Data3>								L	<Response_Data3>								L	
	13	Dependent on non-cyclic command								ML	Dependent on non-cyclic command								ML	
14									MH									MH		
15									H									H		

Title	Command	Response						
<Command_Data1> Command_Speed (CSPD)	Instruction speed [Size]: Signed 32-bit [Unit]: Setting value of Pr.7.25 RTEX speed unit setup <table border="1" style="margin-left: 20px;"> <tr> <th>Pr.7.25</th> <th>Unit</th> </tr> <tr> <td>0</td> <td>[r/min]</td> </tr> <tr> <td>1</td> <td>[Command unit/s]</td> </tr> </table> [Setting range]: - motor maximum speed to motor maximum speed	Pr.7.25	Unit	0	[r/min]	1	[Command unit/s]	-
Pr.7.25	Unit							
0	[r/min]							
1	[Command unit/s]							
<Response_Data1> Actual_Position (APOS)	-	Default: Actual position of motor [Size]: Signed 32-bit [Unit]: Command unit						

- For selection method of Response\_Data 1, see 4-3-1.

5-6 Cyclic torque control (CT) command (Command code: 4□h)

In this torque control mode, the host controller generates the command torque and updates it (or transmits updated command) at the communication cycle.

Upon receiving this command, the servo driver switches the internal control mode to torque control.  
For detailed torque control block diagram, refer to Technical Reference, SX-DSV02202”Section 5-2-3”, Functional Specification.

Receiving this command in the full-closed control mode causes a command error.

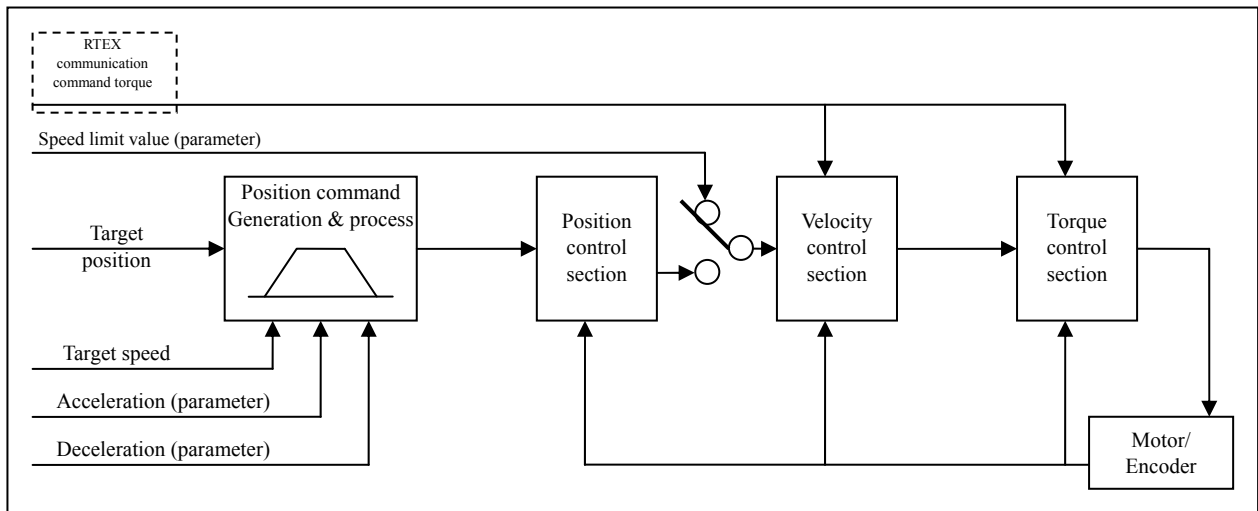

	Byte	Command								Byte	Response									
		bit7	6	5	4	3	2	1	0		bit7	6	5	4	3	2	1	0		
Cyclic	0	C (0)	Update_Counter		MAC-ID				0	R (1)	Update_Counter Echo		Actual_MAC-ID							
	1	TMG_CNT	Command_Code (4□h)								1	CMD_Error	Command_Code_Echo (4□h)							
	2	Control_Bits								2	Status_Flags									
	3																			
	4	<Command_Data1>				L	4	<Response_Data1>				L								
	5	Command_Torque (CTRQ)				ML	5	Default: Actual_Position (APOS)				ML								
	6	[0.1%]				MH	6	[Command unit]				MH								
7					H	7					H									
Non-Cyclic	8	<Command_Data2>				L	8	<Response_Data2>				L								
	9	Dependent on non-cyclic command				ML	9	Dependent on non-cyclic command				ML								
	10					MH	10					MH								
	11					H	11					H								
	12	<Command_Data3>				L	12	<Response_Data3>				L								
	13	Dependent on non-cyclic command				ML	13	Dependent on non-cyclic command				ML								
	14					MH	14					MH								
15					H	15					H									

Title	Command	Response
<Command_Data1> Command_Torque (CTRQ)	Instruction speed [Size]: Signed 32-bit [Unit]: 0.1% [Setting range]: - motor maximum torque to motor maximum torque	-
<Response_Data1> Actual_Position (APOS)	-	Default: Actual position of motor [Size]: Signed 32-bit [Unit]: Command unit

- For selection method of Response\_Data 1, see 4-3-1.

## 6. Non-cyclic Command Description

### 6-1 Non-cyclic command list [Under review]

Non-cyclic commands such as parameter set up are event driven type command.

For details of transmission protocol, refer to Chapter 3.

For details of operation, refer to 6-2 and subsequent sections.

Non-cyclic command code	Title	Description	Supporting sub-command	Cyclic command (correspondence relation with □ shown under "non-cyclic command code")				
				NOP (0h)	PP (1h)	CP (2h)	CV (3h)	CT (4h)
□0h	Normal	Use this command for normal operation. This command is reference non-cyclic command.	○	○	○	○	○	○
□1h	Reset	Use this command to reset the servo driver, or to enable attribute C parameter without resetting the servo driver.	-	▲	○	○	○	○
□2h	System ID	Use this command to read the system ID of the servo driver. Information specified by Type_Code and Index will be returned in ASCII code.	○	▲	○	○	○	○
□4h	Return to home	Use this command to start return to home operation, to latch position information etc.	-	-	△	○	△	△
□5h	Alarm	Use this to read an alarm code, to clear the current alarm etc.	-	-	○	○	○	○
□6h	Parameter	Use this to read out or write parameter, to write to EEPROM etc.	-	-	○	○	○	○
□7h	Profile	Use this to start operation in the profile position control mode (PP).	-	-	○	-	-	-
□Ah	Monitor	Use this to monitor position error, loading factor, etc.	○	-	○	○	○	○
-	Command error	Response is returned if the servo driver cannot receive an incomplete command, or Byte 1, bit 7 is 1.	-	-	-	-	-	-
(FFh) Response only	Communication error	The servo driver will send this response as it detects communication error (CRC error). Upon detecting the CRC error, servo driver will use the previously received command for controlling. (During CP controlling, command position is controlled using estimated position.)	-	-	-	-	-	-

▪ ○: Supported; △: Partially supported; ▲: Supported by the manufacturer (for specific applications only); -: Not supported



6-2 Normal command (Command code: □0h)

Command used for normal operation.

This command is also reference command of non-cyclic command.

Compatible control mode				
NOP	PP	CP	CV	CT
○	○	○	○	○

■ Main command: common to 16 byte and 32 byte mode

Byte	Command								Byte	Response									
	bit7	6	5	4	3	2	1	0		bit7	6	5	4	3	2	1	0		
0	C (0)	Update_Counter		MAC-ID					0	R (1)	Update_Counter Echo		Actual_MAC-ID						
1	TMG_ CNT	Command_Code (□0h)								1	CMD_ Error	Command_Code_Echo (□0h)							
2	Control_Bits								2	Status_Flags									
3									3										
4									L	4									L
5	Command_Data1								ML	5	Response_Data1								ML
6									MH	6									MH
7									H	7									H
8									L	8									L
9	Command_Data2								ML	9	Response_Data2								ML
10									MH	10									MH
11									H	11									H
12									L	12									L
13	Command_Data3								ML	13	Response_Data3								ML
14									MH	14									MH
15									H	15									H

■ Sub-command: specific to 32 byte mode

Byte	Command								Byte	Response									
	bit7	6	5	4	3	2	1	0		bit7	6	5	4	3	2	1	0		
16	Sub_ Chk (1)	0	0	0	Sub_Command_Code (0h)				16	Sub_ CMD_ Err	Sub_ ERR	Sub_ WNG	Sub_ Busy	Sub_Command_Code_Ech o (0h)					
17	Sub_Type_Code								17	Sub_Type_Code_Echo									
18									L	18									L
19	Sub_Index								H	19	Sub_Index_Echo								H
20									L	20									L
21	Sub_Command_Data1								ML	21	Sub_Response_Data1								ML
22									M	22									M
23									H	23									H
24									L	24									L
25	Sub_Command_Data2								ML	25	Sub_Response_Data2								ML
26									M	26									M
27									H	27									H
28									L	28									L
29	Sub_Command_Data3								ML	29	Sub_Response_Data3								ML
30									M	30									M
31									H	31									H

Title	Command	Response
Command_Data2 /Response_Data2	Optional	Data specified by Pr.7.30 RTEX monitor select 2
Command_Data3 /Response_Data3	Data specified by Pr.7.35 RTEX command setup 1 ▪ For details, refer to Sections 7-7-1.	Data specified by Pr.7.31 RTEX monitor select 3
Sub_Type_Code	Optional	—
Sub_Index	Optional	—
Sub_Command_Data1 /Sub_Response_Data1	Optional	Data specified by Pr.7.32 RTEX monitor select 4

6-3 Reset Command (Command code: □1h)

Use this command to reset the servo driver, or to enable attribute C parameter without resetting the servo driver.

Compatible control mode				
NOP	PP	CP	CV	CT
▲	○	○	○	○

<Precautions>

Before starting the reset command assure the safety: make sure that servo is off and apply brake to the motor as necessary.

■ Main command: common to 16 byte and 32 byte mode

	Byte	Command								Byte	Response							
		bit7	6	5	4	3	2	1	0		bit7	6	5	4	3	2	1	0
Cyclic	0	C (0)	Update_Counter		MAC-ID				0	R (1)	Update_Counter Echo		Actual_MAC-ID					
	1	TMG_CNT	□1h						1	CMD_Error	□1h							
	2	Control_Bits						2	Status_Flags									
	3							3										
	4							L	4									
	5							ML	5									
	6	Command_Data1						M	6	Response_Data1								
	7							H	7									
Non-cyclic	8	Type_Code						L	8	Type_Code Echo								
	9	0						H	9	ERR	WNG	0	Busy					
	10	Index						L	10	Index Echo								
	11	(0)						H	11	(0)								
	12							L	12									
	13							ML	13									
	14	Command_Data3						M	14	Monitor_Data								
	15							H	15	(0)								

■ Sub-command: specific to 32 byte mode

(Not supported): Cannot be used by a sub-command. Use only with the main command.

Title	Command	Response						
Type_Code /Type_Code_Echo	Reset mode setup <table border="1" style="margin-left: 20px;"> <thead> <tr> <th>Setting value</th> <th>Description</th> </tr> </thead> <tbody> <tr> <td>001h</td> <td>Software reset mode</td> </tr> <tr> <td>011h</td> <td>Attribute C parameter validation mode</td> </tr> </tbody> </table> ▪ For details, refer to Sections 6-3-1 and 6-3-2.	Setting value	Description	001h	Software reset mode	011h	Attribute C parameter validation mode	Type_Code echo back value.
Setting value	Description							
001h	Software reset mode							
011h	Attribute C parameter validation mode							
Index /Index_Echo	Set to 0	Return 0						
Command_Data3 /Monitor_Data	Data specified by Pr.7.35 RTEX command setup 1 ▪ For details, refer to Sections 7-7-1.	Return 0						

### 6-3-1 Software reset mode (Type\_Code: 001h)

Use this mode when resetting (restarting) servo driver without turning off control power (software resetting).

Reset process has to be executed after confirming that the all of servo drivers have received reset command (□1h) normally, because it is necessary to reset surely all servo drivers even if the communication error occurs.

For this purpose, the servo driver resets itself at transition from the reset command (□1h) to normal command (□0h).

If the communication error occurs at transition from the reset command to normal command, there might be case that only some of the drivers can receive the normal command. In this case, the servo driver also resets itself if the communication time-out has occurred in the condition that the last command was Reset command (□1h).

The following shows the procedures to reset servo drivers.

- 1) Change command code of all servo drivers from normal command (□0h) to Reset command (□1h). Also, be sure to set Type\_Code to 001h and Index and Setting\_Data to 0.
- 2) Confirm that the value of Command Code Echo sent from all servo drivers is (□1h), and then return to normal command (□0h).
- 3) The servo driver will start executing a reset process when normal command (□0h) has been received normally, or when the communication time-out has occurred in the condition that the last received command was Reset command (□1h).
- 4) Since there is no response from servo drivers due to the reset state, the master will detect the communication time-out. When the time-out is detected, reset the communication ASIC (MNM1221) and initialize the communication again.

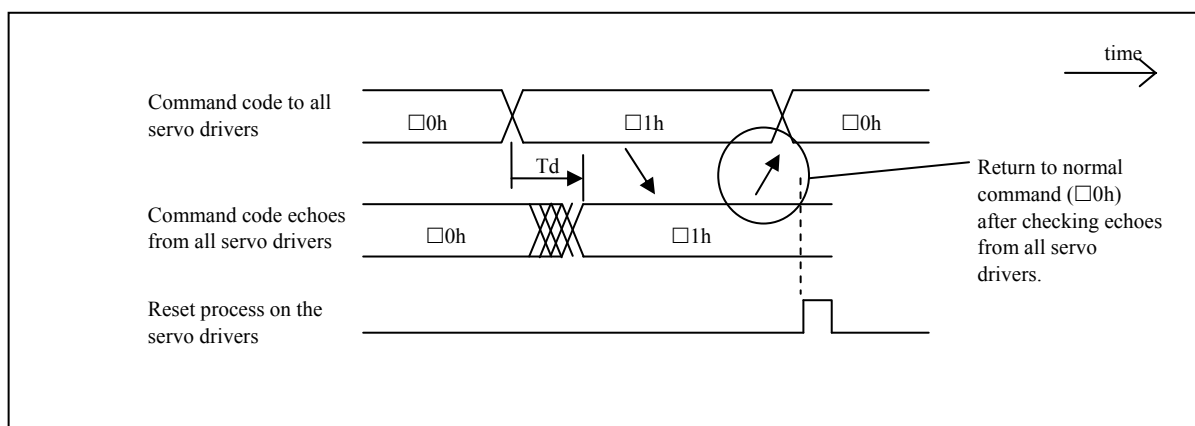

Note: During resetting process, output signal (output transistor) is OFF.

### 6-3-2 Attribute C parameter validation mode (Type\_Code: 011h)

Use this mode when validating the changed parameter of attribute C after establishing communication without turning off control power or resetting (software reset) servo driver.

When validating attribute C, it is not necessary to write this parameter to EEPROM before executing the command (prewriting is optional).

Because the parameter of attribute R becomes effective only after resetting, it is not made effective by this command. Reset the control power source or perform software reset (Type\_Code = 001h). In this case, it is necessary to write the parameter to EEPROM beforehand.

For attribution of a specific parameter, refer to Technical Reference, SX-DSV02202"Section 9-1", Functional Specification.

- When this command is received in servo-on status, it causes the command error (0045h). While processing the command, keep servo-off status. When servo is turned on (Servo\_On = 1) during processing of this command, Err. 27.7 Position information initialization error protection will occur.
- While executing this command, maintain this command and command argument (e.g. Type\_Code).
- After execution of the command, all position information including actual position is initialized. This means that return to home is not completed (provided not in absolute mode) and latch is not completed. After successful completion of the command, repeat the return to home. Status and output signals during command execution are as shown below.

Status/output signal	Before execution	Executing	After execution
Position information	Current position information	Initialization	Information on the current position with reference to initialized position *1)
Return to home status	Current status	Undefined	<ul style="list-style-type: none"> <li>• Unfinished while incrementing</li> <li>• Finished in absolute mode</li> </ul>
Latch status	Current status	Undefined	Unfinished
Busy (non-cyclic status)	0	1	0
Other status	Current status	Undefined	Current status
Output signal	Current status	Undefined	Current status

\*1) Information on position after initialization

<Incremental mode> All position information = 0

<Absolute mode> All position information = Value of absolute encoder (scale)/electronic gear ratio + Pr.7.13  
Absolute home position offset

- While executing the command, do not run the setup support software PANATERM.

6-4 System ID Command (Command code: □2h)

Use this when you read out the system ID of the servo driver.  
Return the information specified by Type\_Code and Index  
in ASCII code.

Compatible control mode				
NOP	PP	CP	CV	CT
▲	○	○	○	○

■ Main command: common to 16 byte and 32 byte mode

Command									Response										
Byte	bit7	6	5	4	3	2	1	0	Byte	bit7	6	5	4	3	2	1	0		
0	C (0)	Update_Counter			MAC-ID					0	R (1)	Update_Counter Echo			Actual_MAC-ID				
1	TMG_CNT	□2h							1	CMD_Error	□2h								
2	Control_Bits								2	Status_Flags									
3									3										
4									4										
5									5										
6	Command_Data1								6	Response_Data1									
7									7										
8	Type_Code								8	Type_Code Echo									
9	0								9	ERR	WNG	0	Busy						
10	Index								10	Index_Echo									
11									11										
12									12										
13	Command_Data3								13	Monitor_Data (ASCII code)									
14									14										
15									15										

■ Sub-command: specific to 32 byte mode

Command									Response								
Byte	bit7	6	5	4	3	2	1	0	Byte	bit7	6	5	4	3	2	1	0
16	Sub_Chk (1)	0	0	0	Sub_Command_Code (2h)				16	Sub_CMD_Err	Sub_ERR	Sub_WNG	Sub_Busy	Sub_Command_Code_Ech o (2h)			
17	Sub_Type Code								17	Sub_Type Code Echo							
18									18								
19	Sub_Index								19	Sub_Index_Echo							
20									20								
21									21								
22	Sub_Command_Data1								22	Sub_Monitor_Data (ASCII code)							
23									23								
24									24								
25	Sub_Command_Data2								25	Sub_Response_Data2							
26									26								
27									27								
28									28								
29	Sub_Command_Data3								29	Sub_Response_Data3							
30									30								
31									31								

Title	Command	Response										
Type_Code /Type_Code Echo	Specify the system ID to be read. ▪ For details, refer Section 6-4-1.	Type_Code echo back value										
Sub_Type_Code /Sub_Type_Code Echo		Type_Code echo back value										
Index/Index Echo												
Sub_Index /Sub_Index Echo												
Command_Data3 /Monitor_Data	Data specified by Pr.7.35 RTEX command setup 1 ▪ For details, refer to Sections 7-7-1.	<table border="1"> <thead> <tr> <th>Byte</th> <th>Read out value (ASCII code)</th> </tr> </thead> <tbody> <tr> <td>12</td> <td>(4 x Index) ASCII code</td> </tr> <tr> <td>13</td> <td>(4 x Index + 1) ASCII code</td> </tr> <tr> <td>14</td> <td>(4 x Index + 2) ASCII code</td> </tr> <tr> <td>15</td> <td>(4 x Index + 3) ASCII code</td> </tr> </tbody> </table>	Byte	Read out value (ASCII code)	12	(4 x Index) ASCII code	13	(4 x Index + 1) ASCII code	14	(4 x Index + 2) ASCII code	15	(4 x Index + 3) ASCII code
Byte	Read out value (ASCII code)											
12	(4 x Index) ASCII code											
13	(4 x Index + 1) ASCII code											
14	(4 x Index + 2) ASCII code											
15	(4 x Index + 3) ASCII code											
Sub_Command_Data1 /Sub_Monirotd_Data	Set to 0											

## 6-4-1 System ID command Type\_Code list

Type_Code *1)		Designation	Description																
Conventional	New																		
010h	01h	Vendor name	“Panasonic”																
050h	05h	Device type	Read out the device type. Example: “1” Servo amplifier (rotary motor)																
060h	06h	Manufacturer use	-																
120h	12h	Driver model No.	Read out the model number of the servo driver. *3) Example: “MADHT1507NA1”																
130h	13h	Driver serial No.	Read out the serial number of the servo driver.																
140h	14h	Servo driver software version	Read out the firmware version of the servo driver. Example: “1.01”																
150h	15h	Driver type	Read out the type of servo driver. Use this command to check the series of the servo driver and functions supported by the servo driver.																
220h	22h	Motor model No.	Read out the model number of the servo motor which is connected to the servo driver. Example: “MSME022G1A”																
230h	23h	Motor serial No.	Read out the serial number of the servo motor which is connected to the servo driver. Example: “10090021”																
310h	31h	Vendor ID of the external scale *2)	Read out the external scale vendor ID and model ID. Example: <table border="1" data-bbox="762 1016 1433 1312"> <thead> <tr> <th>Vendor ID</th> <th>Vendor name</th> <th>Model ID</th> <th>Model name</th> </tr> </thead> <tbody> <tr> <td rowspan="2">‘3’</td> <td rowspan="2">Mitutoyo Corporation</td> <td>‘1’</td> <td>AT573A</td> </tr> <tr> <td>‘2’</td> <td>ST770A, /ST770AL</td> </tr> <tr> <td rowspan="2">‘4’</td> <td rowspan="2">Magnescale Co., Ltd.</td> <td>‘1’</td> <td>SR77 /SR87</td> </tr> <tr> <td>‘2’</td> <td>SR75 /SR85</td> </tr> </tbody> </table>	Vendor ID	Vendor name	Model ID	Model name	‘3’	Mitutoyo Corporation	‘1’	AT573A	‘2’	ST770A, /ST770AL	‘4’	Magnescale Co., Ltd.	‘1’	SR77 /SR87	‘2’	SR75 /SR85
Vendor ID	Vendor name	Model ID	Model name																
‘3’	Mitutoyo Corporation	‘1’	AT573A																
		‘2’	ST770A, /ST770AL																
‘4’	Magnescale Co., Ltd.	‘1’	SR77 /SR87																
		‘2’	SR75 /SR85																
320h	32h	Model ID of the external scale *2)																	
340h	34h	Manufacturer use	-																

\*1) Command Error (0031h) will be returned at setting up the wrong Type Code.

\*2) In the following cases, Vendor ID of the external scale and Model ID of the external scale return 0 (NULL).

- When External scale position information monitoring facility at the semi-closed control is invalid.
- When reading out the data from the external scale is failed.
- When AB phase output is not the serial communication type.

\*3) The 4th character in the model number also represents the series of the servo driver.

Series	4th character in the model number
MINAS-A4N	D
MINAS-A5N	H

\*4) Compatible Type\_Code: compatible with that for A4N and can be used only with main command.

New Type\_Code: Prepared for A5N and can be used with both main command and subcommand. When using with main command, set upper 4-bit to 0.

\* Although the product supports conventional Type\_Code to maintain compatibility, basically use the new Type\_Code.

## 6-4-2 Example of reading of vendor name (“Panasonic”)

Byte		1st	2nd	3rd
8	Type_Code_Echo	01h	01h	01h
9				
10	Index_Echo	0	1	2
11				
12	ASCII code	‘P’	‘s’	‘c’
13	ASCII code	‘a’	‘o’	0 (NULL) *1)
14	ASCII code	‘n’	‘n’	0 (NULL) *1)
15	ASCII code	‘a’	‘i’	0 (NULL) *1)

\*1) The servo driver will return 0 (NULL) at the end of the character string.

## 6-4-3 Device type

Device type is identified as follows:

With this servo driver, “1” will be returned.

Device type	Description
‘0’	(Reserved)
‘1’	Servo driver
‘2’	Stepping
‘3’	Pulse OUT
‘4’	Digital IN
‘5’	Digital OUT or IN & OUT
‘6’	Analog IN
‘7’	Analog OUT or IN & OUT
‘8’	(Reserved)
‘9’	Gateway
‘A’-‘F’	(Reserved)
‘10’	(Reserved)
‘11’	(Reserved)

Note: Conventional MINAS-A4N does not support the device type.

## 6-4-4 Servo driver type

Driver type is identified as follows:

Rotary type driver of MINAS-A5N series of the standard specification will response as shown below.

Index 0   Byte12 = '1'

          Byte13 = '0'

          Byte14 = '1'

          Byte15 = '1'

Index 1   Byte12 = '1'

          Byte13 = '1'

Index	0				1				2	3	4 and subsequent	
Byte	12	13	14	15	12	13	14	15	12-15	12-15	12-15	
Series/function	Driver series	Type of motor connected	CP control	CV control	CT control	PP control	(Reserved)	(Reserved)	(Reserved)	(Reserved)	-	
Servo driver type	'0'	A4N	Rotary type	Unsupported	Unsupported	Unsupported	Unsupported	(Reserved)	(Reserved)	(Reserved)	(Reserved)	0
	'1'	A5N	Linear type	Supported	Supported	Supported	Supported					(NULL)
	Other	(Reserved)	(Reserved)	(Reserved)	(Reserved)	(Reserved)	(Reserved)					*1)

\*1) Returned 0 (NULL) indicates the end of character string.

Note: Conventional MINAS-A4N does not support the servo driver type.



## 6-5 Homing command (Command code: □4h)

Use this command when performing homing, latching actual position, etc.

Compatible control mode				
NOP	PP	CP	CV	CT
-	△	○	△	△

For details of return to home operation, refer to Section 7-2.

■ Main command: common to 16 byte and 32 byte mode

Byte	Command								Byte	Response									
	bit7	6	5	4	3	2	1	0		bit7	6	5	4	3	2	1	0		
0	C (0)	Update_Counter		MAC-ID					0	R (1)	Update_Counter Echo		Actual_MAC-ID						
1	TMG_CNT	□4h								1	CMD_Error	□4h							
2	Control_Bits								2	Status_Flags									
3									3										
4	Command_Data1								L	4	Response_Data1								L
5									ML	5									ML
6									M	6									MH
7									H	7									H
8	Type_Code								8	Type_Code Echo									
9	0								9	ERR	WNG	0	Busy	0	0	Latch_Comp2	Latch_Comp1		
10	Latch_Sel2				Latch_Sel1				10	Latch_Sel2 Echo				Latch_Sel1 Echo					
11	Monitor_Sel								11	Monitor_Sel Echo									
12	Setting_Data (Command_Data3)								L	12	Monitor_Data								L
13									ML	13									ML
14									M	14									MH
15									H	15									H

■ Sub-command: specific to 32 byte mode

(Not supported): Cannot be used by a sub-command. Use only with the main command.

Title	Command	Response
Type_Code /Type_Code Echo	Type of return-to-home ▪ For detailed description, refer to Section 6-5-1.	Type_Code echo back value
Latch_Comp1, Latch_Comp2	-	Latch position 1/2 complete state ▪ For detailed description, refer to Section 6-5-4.
Latch_Sel1, Latch_Sel2, /Latch_Sel1_Echo, Latch_Sel2_Echo,	<In latch mode> Selection of position latch 1 (Ch1) or position latch 2 (Ch2) trigger signal ▪ For detailed description, refer to Section 6-5-4.  <Mode other than latch> Set to 0.	<In latch mode> Latch_Sel1, Latch_Sel2 echo back value ▪ For detailed description, refer to Section 6-5-4.  <Mode other than latch> Latch_Sel1, Latch_Sel2 (= 0) echo back value
Monitor_Sel /Monitor_Sel Echo	<In latch mode> Selection of data to be returned to Monitor_Data ▪ For detailed description, refer to Section 6-5-4.  <Mode other than latch> Set to 0.	<In latch mode> Selection of data to be returned to Monitor_Data ▪ For detailed description, refer to Section 6-5-4.  <Mode other than latch> Monitor_Sel(=0) echo back value
Setting_Data (Command_Data3) /Monitor_Data	<Actual position setup and command position setup> Actual position setting value and command position setting value [Size]: Signed 32-bit [Unit]: Instruction unit [Setting range]: 8000000h~7FFFFFFh (-2147483648 to 2147483647)  <Non-actual position setup and Non-command position setup> Data specified by Pr.7.35 RTEX command setup 1 ▪ For details, refer to Sections 7-7-1.	<Actual position setup/command position setup> Echo back of actual position setting value/command position setting value [Size]: Signed 32-bit [Unit]: Instruction unit  <In latch mode> Monitor data selected through Monitor_Sel ▪ For detailed description, refer to Section 6-5-4.  <When not in actual position setup, command position setup or latch mode> Return 0

6-5-1 Type Code list of Homing Command

Position information with/without initialization	Type Code *1)	Type of return-to-home (reference trigger)	Pr.0.01(Control mode setup)															Servo-on status		Homing_Ctrl bit used/unused			
			0: Semi-closed										6: Full-closed										
			Profile position control (PP)			Cyclic position control (CP)			Cyclic velocity control (CV)			Cyclic torque control (CT)			Profile position control (PP)			Cyclic position control (CP)					
			SER INC	SER ABS INC	SER ABS ABS	SER INC	SER ABS INC	SER ABS ABS	SER INC	SER ABS INC	SER ABS ABS	SER INC	SER ABS INC	SER ABS ABS	SER INC	ABZ INC	SER ABS	SER INC	ABZ INC		SER ABS	ON	OFF
[With] Initialization mode	11h	Z- phase	-	-	-	o	o	-	-	-	-	-	-	-	-	-	-	o	o	-	o	-	Used
	12h	HOME↑ *2)																					
	13h	HOME↓ *3)																					
	14h	POT↑ *2)																					
	15h	POT↓ *3)																					
	16h	NOT↑ *2)																					
	17h	NOT↓ *3)																					
	18h	EXT1↑ *2)	-	-	-	o	o	-	-	-	-	-	-	-	-	-	-	o	o	-	o	-	
	19h	EXT1↓ *3)																					
	1Ah	EXT2↑ *2)																					
	1Bh	EXT2↓ *3)																					
	1Ch	EXT3↑ *2)																					
	1Dh	EXT3↓ *3)																					
	[Without] Latch mode	21h	Actual position set	o	o	-	o	o	-	-	-	-	-	-	-	o	o	-	o	o	-	o	
22h		Command position set																					
31h		Clear multi-turn data of absolute encoder	-	-	o	-	-	o	-	-	o	-	-	o	-	-	-	-	-	-	-	o	
[Without] Latch mode	50h	Position latch Status monitor																					Unused
	51h	Position latch 1 Start																					
	52h	Position latch 2 Start																					
	53h	Position latch 1, 2 Start	o	o	o	o	o	o	o	o	o	o	o	o	o	o	△ *4)	o	o	△ *4)	o	o	
	54h	Position latch 1 Cancel																					
	58h	Position latch 2 Cancel																					
	5Ch	Position latch 1, 2 Cancel																					

- \*1) Command error (0031h) will be returned at setting up the wrong type code.
- \*2) [↑]: Logical rising edge of external input signal (off → on timing of internal processing)
- \*3) [↓]: Logical falling edge of external input signal (on → off timing of internal processing)
- \*4) Because the absolute external scale of serial communication type does not have Z-phase, Z-phase cannot be set to latch trigger signal: command error (005Ah) will be returned.

▪ o: Supported; △: Partially supported; -: Not supported

Terms in table above	Semi-closed	Full-closed
SER_INC	20-bit incremental encoder	Serial communication type incremental external scale
SER_ABS	17-bit absolute encoder	Serial communication type absolute external scale
INC in SER_ABS	Use 17-bit absolute encoder in the incremental mode	-
ABS in SER_ABS	Use 17-bit absolute encoder in the absolute mode	-
ABZ_INC	-	ABZ output type incremental external scale

Example: When Type\_Code = 18h

- Semi-closed position control (CP) and SER\_INC, or full-closed position control (CP) and SER\_INC or ABZ\_INC
  - Servo on status
  - Homing\_Ctrl bit is 1
  - Initialization to clear position information (actual position/internal command position) to 0 at the timing logical level of EXT1 signal rises from 0 → 1.
  - Internal process includes position correction during arithmetic process (sampling).
- 
- Profile absolute positioning/relative positioning, actual position setup during continuous rotation (In\_Progress = 1) and command position setup will be possible but it will cancel PP operation. Performing Type\_Code = 1□h, 31h will cause Err.91.1 (RTEX command error protection) and command error (0059h). The latch mode can be started during PP operation.
  - During profile position latch absolute positioning/relative positioning and profile homing 1/2/3, these processes overlap. Therefore, do not use this command (any Type\_Code). Otherwise, Err.91.1 (RTEX command error protection), command error (0059h) will occur.
  - Perform the clear multi-turn data of absolute encoder while maintaining servo-off condition. If servo is on, command error (0056h) will occur.
  - For other possible causes of error, refer to 6-10-2.
  - Homing\_Ctrl bit is not used for control of Actual position setting, Command position setting and clearing of multi-turn data of absolute encoder.
  - When Type\_Code is 05□h, the position information is not initialized and the actual position is latched as the trigger is detected.
  - Edge will be detected in logic level of the signal, and not physical level.
  - In the full-closed control mode, the reference position of the return-to-home is in Z-phase of external scale, and not Z-phase of encoder.
  - When POT/NOT is the home position reference trigger, be sure to set Pr.5.04 Over-travel inhibit input setup to 1, to disable the over-travel inhibit input. Otherwise, Err. 38.2 Drive inhibit input protection 3 will occur.
  - For precautions on assignment of external signal associated with the return-to-home sequence, refer to Section 6-5-2.
  - When the position information is initialized, the latched status is changed to unlatched status.

## 6-5-2 Assignment of external input signals related to return to home sequence

When allocating the return-to-home related external inputs (HOME, POT, NOT, EXT1, EXT2 and EXT3) to the internal terminals, note the following:

- 1) When using home position reference trigger, allocation can be made only to latch correction terminals (SI5, SI6 and SI7) through NO contact.
- 2) EXT1 can be allocated only to SI5, EXT2 only to SI6 and EXT3 only to SI7.
- 3) When using HOME, POT and NOT as home position reference trigger, HOME can be allocated only to SI5, POT only to SI6 and NOT only to SI7 through a contact.

Note: When POT or NOT is allocated to the latch correction terminal, a contact is used: drive inhibit input is not active when cable is disconnected. Therefore, safety must be secured by a different measure such as mechanical stopper.

- 4) When allocating EXT1, EXT2, EXT3, HOME, POT or NOT to latch correction terminal (SI5, SI6 or SI7), allocate the same signal in all control modes.

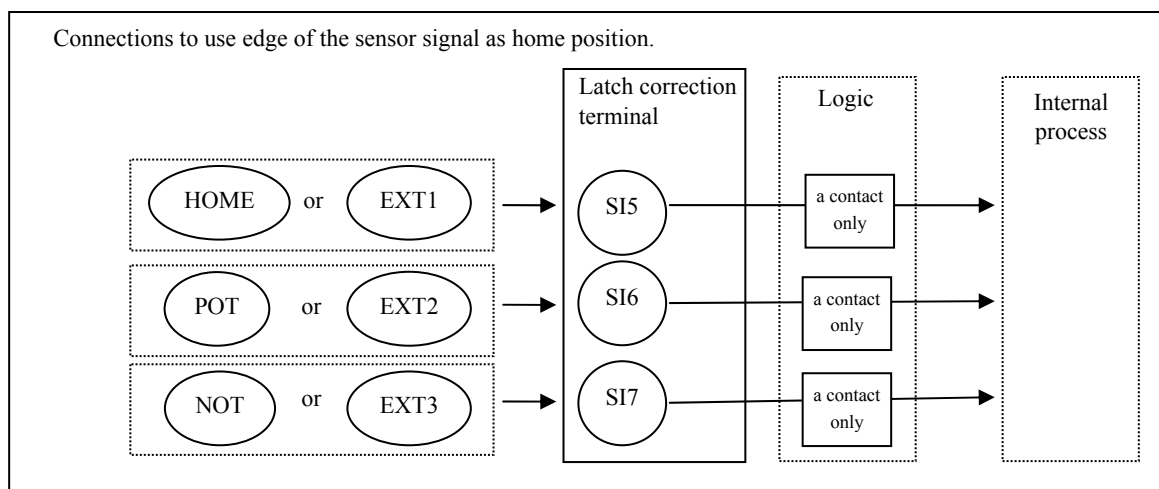

If the conditions 1) to 4) are not met, Err. 33.8 External latching input allocation error will occur.

- 5) If HOME, POT and NOT are not the home reference trigger, they can be allocated to normal terminal (SI1, SI2, SI3, SI4 and SI8).

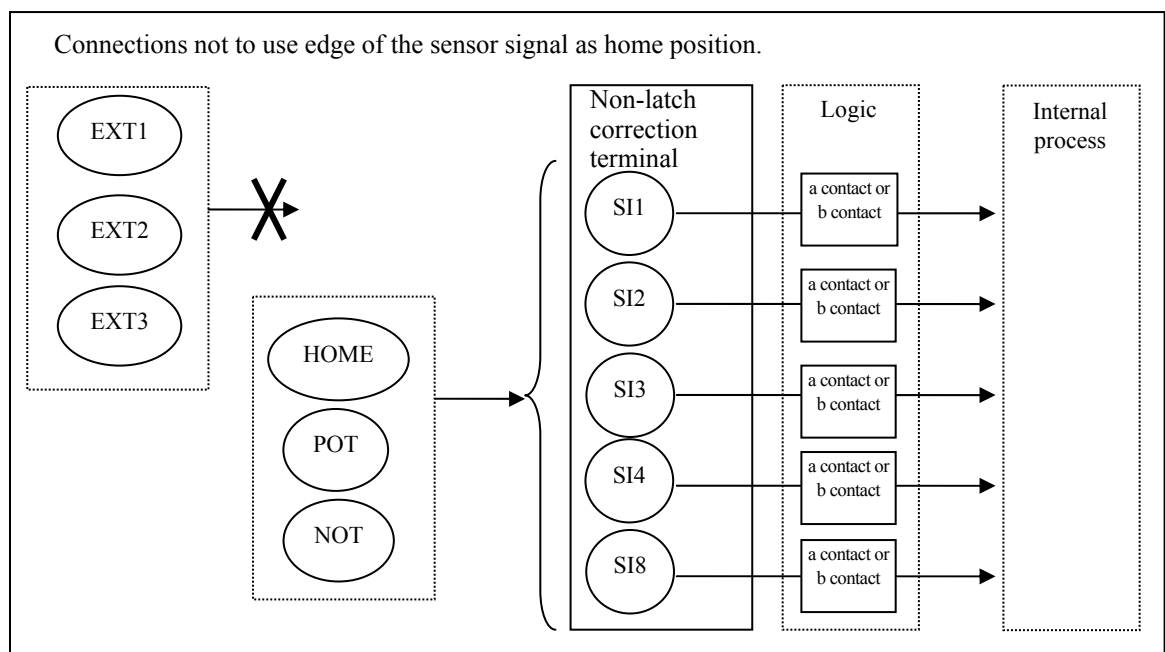

## 6-5-3 Actual position setup and command position setup

Below shows the internal position information in the servo driver while executing the actual position setup (Type\_Code = 021h) and command position setup (Type\_Code = 022h).

Type_Code	Designation	Position information after execution
021h	Actual position setup	Actual position = internal command position = setting value (Setting_Data) Position deviation = 0
022h	Command position setup	Internal command position = setting value (Setting_Data) Actual position = internal command position (after setting as described above) – position deviation

## &lt;Initialization of position information by actual position setup&gt;

Initialize the motor position (actual position at the time the servo driver received the command) to the setting value to clear the position deviation, and set the internal command position to the motor position (actual position). Subsequently, when the host controller issues a command and motor moves, initialized motor position may deviate from the target position. If this positional deviation may cause problem, use the command position set.

- Expected application: Homing using stopper See 7-2-3-4.

(If high accuracy is not required: current motor position is initialized to the setting value.)

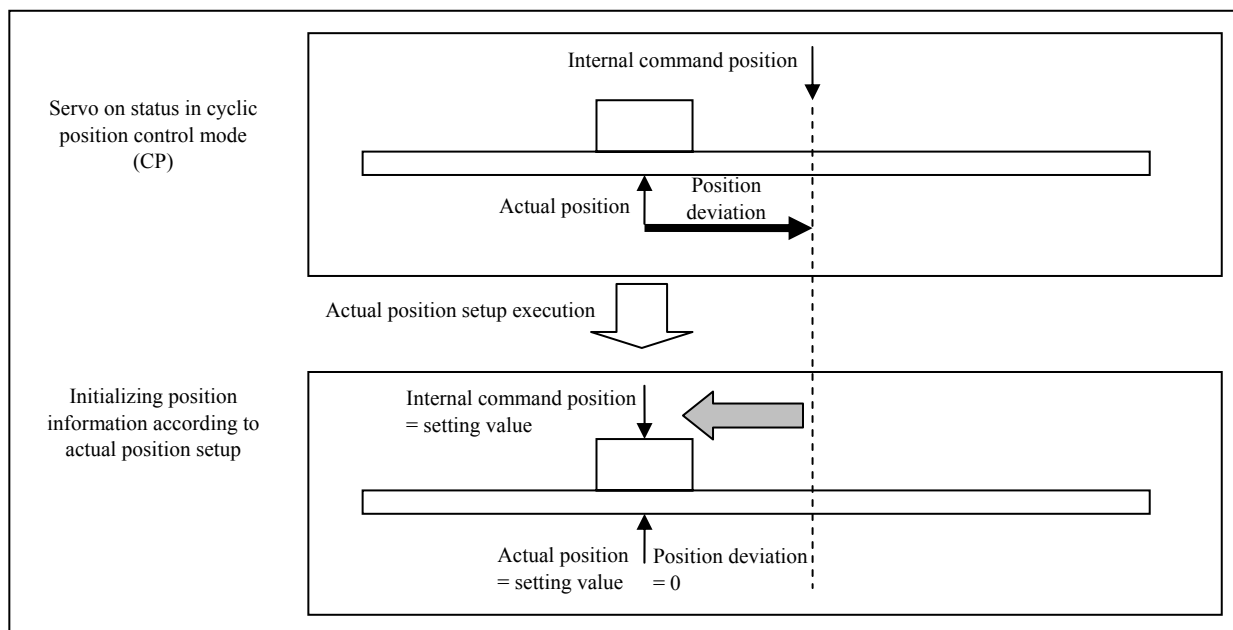

## &lt;Initialization of position information according to command position setup&gt;

Upon receiving a command from the host controller, servo driver initializes the internal command position to the setting value while maintaining the current position deviation, and then determines the motor actual position by subtracting position deviation from the setting value. As a result, the motor position is initialized to the presumed position even if the motor moves after the host controller has issued a command provided that the internal command position (after filter) is stopped.

■ Expected application: Homing with respect to latched position

(High accuracy required: internal command position is initialized to the setting value after positioning to the latched position)

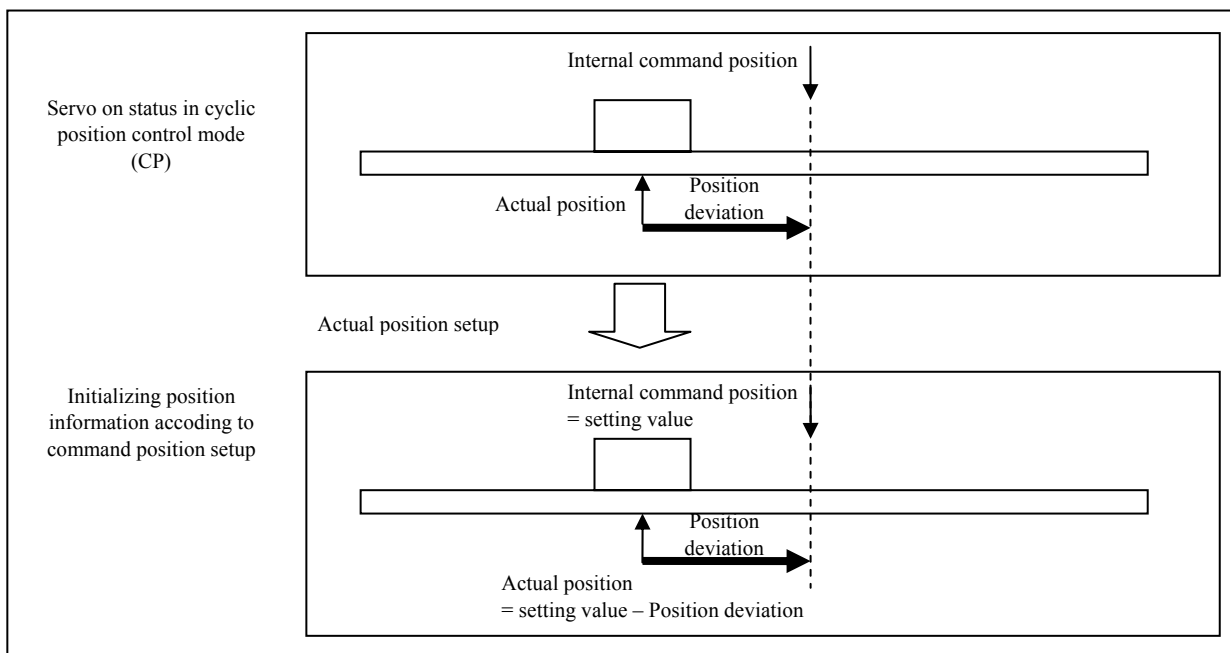

### 6-5-4 Latch mode

In the latch mode (Type\_Code = 5□h), the motor actual position can be latched and read at the input timing of trigger signal without initializing position information.

While in the latch mode, Busy as latch process remains 0. This means that any other command e.g. parameter command can be executed while in the latch mode. However, commands that initialize position information, such as reset command and homing command (except for latch mode) forcibly cancel the established latch mode.

#### 6-5-4-1 Starting/canceling latch mode

To start/cancel the latch mode, use Type\_Code.

2CHs can be put in the latch mode at the same time.

Byte	Command								Byte	Response							
	bit7	6	5	4	3	2	1	0		bit7	6	5	4	3	2	1	0
8	5				Latch_Dis2	Latch_Dis1	Latch_Ena2	Latch_Ena1	8	5				Latch_Dis2_Echo	Latch_Dis1_Echo	Latch_Ena2_Echo	Latch_Ena1_Echo

Type_Code	Type_Code				Description
	Latch_Dis2	Latch_Dis1	Latch_Ena2	Latch_Ena1	
50h	0	0	0	0	Position latch status monitor ▪ Use this to monitor the status without additional starting or canceling.
51h	0	0	0	1	Start position latch 1 (CH1).
52h	0	0	1	0	Start position latch 2 (CH2).
53h	0	0	1	1	Start position latch 1 (CH1) and 2 (CH2).
54h	0	1	0	0	Cancel position latch 1 (CH1).
58h	1	0	0	0	Cancel position latch 2 (CH2).
5Ch	1	1	0	0	Cancel position latch 1 (CH1) and 2 (CH2).

In the table above, “0” means to maintain the current latch start/cancel command without additional latch request/cancel.

#### 6-5-4-2 Selecting latch trigger signal

To select the latch trigger signal, use Latch\_Sel1 and Latch\_Sel2.

Byte	Command								Byte	Response							
	bit7	6	5	4	3	2	1	0		bit7	6	5	4	3	2	1	0
10	Latch_Sel2				Latch_Sel1				10	Latch_Sel2_Echo				Latch_Sel1_Echo			

Latch_Sel1, Latch_Sel2	Setting value	Latch trigger signal
		0
1		Logical rising edge of EXT1
2		Logical rising edge of EXT2
3		Logical rising edge of EXT3
4-8		Do not use. If it chooses, a command error (0032h) will be returned.
9		Logical falling edge of EXT1
10		Logical falling edge of EXT2
11		Logical falling edge of EXT3
12-15		Do not use. If it chooses, a command error (0032h) will be returned.

## 6-5-4-3 Checking latch mode complete status and latch position data

To check the end status of the latch mode, monitor Latch\_Comp1 and Latch\_Comp2.

To monitor the latch complete status (Latch\_Comp1 and Latch\_Comp2) again after executing another command, use Type\_Code = 50h.

Latch position 1/2 can also be checked by using monitor command.

Byte	Command								Byte	Response							
	bit7	6	5	4	3	2	1	0		bit7	6	5	4	3	2	1	0
9	0								9	ERR	WNG	0	Busy	0	0	Latch_Comp2	Latch_Comp1

	Description
Latch_Comp1	0: Latch not completed at latch position 1 (CH1) 1: Latch completed at latch position 1 (CH1)
Latch_Comp2	0: Latch not completed at latch position 2 (CH2) 1: Latch completed at latch position 2 (CH2)

Received latch position 1/2 data can be monitored by using Monitor\_Data.

Using Monitor\_Sel, select the data to be read out by Monitor\_Data.

Use monitor command Type\_Code (8-bit) for A5N to set Monitor\_Sel.

Byte	Command								Byte	Response									
	bit7	6	5	4	3	2	1	0		bit7	6	5	4	3	2	1	0		
11	Monitor_Sel								11	Monitor_Sel_Echo									
12	Command_Data3								L	12	Monitor_Data								L
13									ML	13									ML
14									M	14									MH
15									H	15									H

Monitor_Sel	Monitor_Data		Description
	Title	Symbol	
09h	Latch position 1	LPOS1	Actual motor position latched with CH1
0Ah	Latch position 2	LPOS2	Actual motor position latched with CH2

Note: Value of latch position 1/2 is undefined until latch is completed. Make sure that Latch\_Comp1 and Latch\_Comp2 are at "1".



6-6 Alarm command (Command code: □5h)

Use this to read out alarm code or clear the present alarm.

Compatible control mode				
NOP	PP	CP	CV	CT
-	○	○	○	○

■ Main command: common to 16 byte and 32 byte mode

Command								Response									
Byte	bit7	6	5	4	3	2	1	0	Byte	bit7	6	5	4	3	2	1	0
0	C (0)	Update_Counter		MAC-ID					0	R (1)	Update_Counter Echo		Actual_MAC-ID				
1	TMG_CNT	□5h							1	CMD_Error	□5h						
2	Control_Bits								2	Status_Flags							
3									3								
4								L	4								L
5								ML	5								ML
6	Command_Data1							M	6	Response_Data1							MH
7								H	7								H
8	Type_Code							L	8	Type_Code Echo							L
9	0							H	9	ERR	WNG	0	Busy				H
10	Index							L	10	Index Echo							L
11								H	11								H
12								L	12	Alarm_Code							Main
13	Command_Data3							ML	13								Sub
14								M	14	Warning_Code							L
15								H	15								H

■ Sub-command: specific to 32 byte mode

(Not supported): Cannot be used by a sub-command. Use only with the main command.

Title	Command	Response				
Type_Code /Type_Code Echo	Type of execution, e.g. alarm readout and clear ▪ For details, refer to Section 6-6-1.	Echo back value of Type_Code				
Index /Index Echo	Set up history number etc. ▪ For details, refer to Section 6-6-1.	<Except for alarm attribute readout> Echo back value of Index  <To read out alarm attribute> <table border="1"> <tr> <td>Index: 0</td> <td>Alarm code being issued</td> </tr> <tr> <td>Index: not 0</td> <td>Echo back value of Index</td> </tr> </table>	Index: 0	Alarm code being issued	Index: not 0	Echo back value of Index
Index: 0	Alarm code being issued					
Index: not 0	Echo back value of Index					
Command_Data3	Data specified by Pr.7.35 RTEX command setup 1 ▪ For details, refer to Sections 7-7-1.	—				
Alarm_Code	—	<Except for alarm attribute readout> Alarm code ▪ For details, see 6-6-1 and 6-6-2.  <To read out alarm attribute> Alarm attribute ▪ For details, see 6-6-3.				
Warning_Code	—	<Except for alarm attribute readout> Warning code ▪ For details, see 6-6-1.  <To read out alarm attribute> Alarm attribute ▪ For details, see 6-6-3.				

## 6-6-1 Alarm command Type\_Code list

Type_Code *1)	Title	Description																		
000h	Read out present alarm or alarm history	<ul style="list-style-type: none"> <li>When Index is 0, present alarm code (Alarm_Code) and warning code (Warning_Code) will be read out.</li> <li>When Index is 1 to 14, past alarm code (alarm history) will be read out. Larger Index value represents older alarm history. Because the warning code (Warning_Code) is not recorded, Index code is always 0.</li> <li>When alarm does not have occurred, 0 will be read at alarm code.</li> </ul> <table border="1"> <thead> <tr> <th>Index</th> <th>Alarm_Code</th> <th>Warning_Code</th> </tr> </thead> <tbody> <tr> <td>0</td> <td>The code representing the current alarm</td> <td>The code representing the current warning</td> </tr> <tr> <td>1</td> <td>The code for the last alarm</td> <td>0</td> </tr> <tr> <td>2</td> <td>The code for the second last alarm</td> <td>0</td> </tr> <tr> <td>:</td> <td>:</td> <td>:</td> </tr> <tr> <td>14</td> <td>The code for the fourteenth last alarm</td> <td>0</td> </tr> </tbody> </table> <ul style="list-style-type: none"> <li>Even if the command code and command argument are stored, they will be updated as the new alarm or warning code is generated.</li> <li>When Index is not 0–14, Command error (0032h) will be returned.</li> <li>Set Data specified by Pr.7.35 RTEX command setup 1 as Command_Data3.</li> <li>When Pr.7.35 RTEX command setup 1 is 0, and Command_Data3 is not 0, Command error (0032h) will be returned.</li> <li>Some alarms are not recorded.</li> <li>When the value read out with Index = 0 is 0, it means that no alarm or warning has occurred.</li> <li>If an alarm occurs while the previously occurred alarm is recorded in the history, the value of the alarm code (Index = 0) for the new alarm is the same as the value of the alarm code (Index = 1) for the preceding alarm.</li> </ul>	Index	Alarm_Code	Warning_Code	0	The code representing the current alarm	The code representing the current warning	1	The code for the last alarm	0	2	The code for the second last alarm	0	:	:	:	14	The code for the fourteenth last alarm	0
Index	Alarm_Code	Warning_Code																		
0	The code representing the current alarm	The code representing the current warning																		
1	The code for the last alarm	0																		
2	The code for the second last alarm	0																		
:	:	:																		
14	The code for the fourteenth last alarm	0																		

Type_Code *1)	Title	Description										
001h	Clear alarm	<ul style="list-style-type: none"> <li>When Index is 0, present alarm and warning will be cleared. And present alarm code (Alarm_Code) and warning code (Warning_Code) will be returned.</li> <li>The command code and command argument, if stored, will be updated.</li> <li>When Index is not 0, Command error (0032h) will be returned.</li> <li>Set Data specified by Pr.7.35 RTEX command setup 1 as Command_Data3.</li> <li>When Pr.7.35 RTEX command setup 1 is 0, and Command_Data3 is not 0, Command error (0032h) will be returned.</li> <li>When you try to execute this command to clear the alarm which is inhibited to clear, or when you try to do so when no warning occurs, command error (0042h) will be returned.(When the alarm which is inhibited to clear and warning occurred on same time, since clearing process of warning is performed, Command error (0042h) is not returned.)</li> <li>Clear the warning by executing this command when “battery warning” of the absolute encoder has occurred. And when the alarm which is inhibited to clear has also occurred, this warning will be cleared.</li> <li>Clearing process may require approx. 10 s for completion.</li> <li>As clearing process starts, warning will be put in “cleared” state for approx. 1 second, even if the cause of warning has not been removed. Note that the 1-second clearing process is not interlocked with Busy.</li> </ul>										
002h	Read out alarm attribute	<ul style="list-style-type: none"> <li>Using Index, specify the number of alarm for reading the alarm attribute. <table border="1" data-bbox="651 1330 1449 1462"> <thead> <tr> <th>Byte</th> <th>Title</th> <th>Specified alarm code</th> </tr> </thead> <tbody> <tr> <td>10</td> <td rowspan="2">Index</td> <td>L</td> <td>Alarm code main number</td> </tr> <tr> <td>11</td> <td>H</td> <td>Alarm code sub number</td> </tr> </tbody> </table> </li> <li>When Index is 0 (L and H are 0), attribute of the current alarm is read, with the alarm code of the current alarm is returned in Index_Echo. If no alarm, Index_Echo and alarm attribute are returned with 0.</li> <li>If undefined alarm code is specified, command error 0032h will be returned.</li> <li>Set Data specified by Pr.7.35 RTEX command setup 1 as Command_Data3.</li> <li>When Pr.7.35 RTEX command setup 1 is 0, and Command_Data3 is not 0, Command error (0032h) will be returned.</li> <li>Alarm attribute is returned in Bytes 12–15 of response.</li> </ul>	Byte	Title	Specified alarm code	10	Index	L	Alarm code main number	11	H	Alarm code sub number
Byte	Title	Specified alarm code										
10	Index	L	Alarm code main number									
11		H	Alarm code sub number									

\*1) Command error (0031h) will be returned at setting up the wrong type code.

Type_Code *1)	Title	Description
011h	Clear alarm history	<ul style="list-style-type: none"> <li>• When Index is 0, all alarm history will be cleared. And present alarm code (Alarm_Code) and warning code (Warning_Code) will be returned.</li> <li>• When Index is not 0, Command error (0032h) will be returned.</li> <li>• Set Data specified by Pr.7.35 RTEX command setup 1 as Command_Data3.</li> <li>• When Pr.7.35 RTEX command setup 1 is 0, and Command_Data3 is not 0, Command error (0032h) will be returned.</li> <li>• Alarm history is stored to EEPROM. When Err. 11.0 Control power supply under-voltage protection occurs, command error (0061h) will be returned because of EEPROM accessing failure.</li> </ul>
021h	Clear error on external scale	<ul style="list-style-type: none"> <li>• When Index is 0 in full-closed control mode, some errors which are detected and latched on the serial communication type external scale will be cleared. (It is not clearing the alarm on the servo driver.) And present alarm code (Alarm_Code) and warning code (Warning_Code) will be returned.</li> <li>• When Index is not 0, Command error (0032h) will be returned.</li> <li>• Set Data specified by Pr.7.35 RTEX command setup 1 as Command_Data3.</li> <li>• When Pr.7.35 RTEX command setup 1 is 0, and Command_Data3 is not 0, Command error (0032h) will be returned.</li> <li>• If in full-closed mode without ABZ external scale, semi-closed control or external scale error, command error (0043h) will be returned.</li> <li>• After executing this command (after the process of clearing the error on the external scale), shut off the power once to reset.</li> <li>• Confirm the specification of the external scale because time necessary to clear the error is different in each external scale.</li> </ul>

\*1) Command error (0031h) will be returned at setting up the wrong type code.

## 6-6-2 Setting up of alarm code

With MINAS-A5N series, an alarm code (Alarm\_Code) is divided into the main and sub numbers. By using bit 1 of Pr.7.23 RTEX function expansion setup 2, however, only the main number can be used as in the case of MINAS-A4N. Note that both the main and sub number should be specified when reading alarm attribute.

Byte	Title		Bit 1 of Pr.7.23	
			0 (compatible with conventional model)	1
12	Alarm_Code	Main	Main number	Main number
13		Sub	0	Sub number

## 6-6-3 Alarm attribute

Byte	bit7	6	5	4	3	2	1	0
12	NOT_REC	NOT_ACLR	EMG-STP	-	-	-	-	-
13	-	-	-	-	-	-	-	-
14	-	-	-	-	-	-	-	-
15	-	-	-	-	-	-	-	-

NOT\_REC: Do not record in alarm history.

NOT\_ACLR: Do not clear.

EMG-STP: Enable emergency stop.

## 6-7 Parameter Command (Command code: □6h)

Use this to read out, to write the parameter and to write to EEPROM.

Compatible control mode				
NOP	PP	CP	CV	CT
-	○	○	○	○

## ■ Main command: common to 16 byte and 32 byte mode

Command								Response									
Byte	bit7	6	5	4	3	2	1	0	Byte	bit7	6	5	4	3	2	1	0
0	C (0)	Update_Counter		MAC-ID					0	R (1)	Update_Counter Echo		Actual_MAC-ID				
1	TMG_CNT	□6h							1	CMD_Error	□6h						
2	Control_Bits								2	Status_Flags							
3									3								
4								L	4								L
5								ML	5								ML
6	Command_Data1							M	6	Response_Data1							M
								H									H
7								H	7								H
8	Type_Code							L	8	Type_Code Echo							L
9	0							H	9	ERR	WNG	0	Busy				H
10	Index							L	10	Index_Echo							L
11								H	11								H
12								L	12								L
13	Setting_Data (Command_Data3)							ML	13	Monitor_Data							ML
14								M	14								M
								H									H
15								H	15								H

## ■ Sub-command: specific to 32 byte mode

(Not supported): Cannot be used by a sub-command. Use only with the main command.

Title	Command	Response
Type_Code /Type_Code Echo	Type of execution, e.g. reading and writing of parameter ▪ For details, refer to Section 6-7-1.	Echo back value of Type_Code
Index /Index Echo	Parameter number (Type, No.) ▪ For details, refer to Section 6-7-1.	Echo back value of Index
Setting_Data (Command_Data3) /Monitor_Data	<Reading parameter> Data specified by Pr.7.35 RTEX command 1 ▪ For details, refer to Sections 7-7-1.	<Reading parameter> Parameter value read out *2) [Size]: Signed 32-bit [Unit]: Dependent on parameter ▪ For details, refer to Section 6-7-1.
	<Writing parameter> Parameter setting value *1) [Size]: Signed 32-bit [Unit]: Dependent on parameter [Setting range]: Dependent on parameter ▪ For details, refer to Section 6-7-1.	<Writing parameter> Parameter value actually written *2) [Size]: Signed 32-bit [Unit]: Dependent on parameter ▪ For details, refer to Section 6-7-1.
	<The number read-out of the parameters in a classification> Data specified by Pr.7.35 RTEX command 1 ▪ For details, refer to Sections 7-7-1.	<The number read-out of the parameters in a classification> The number of parameters in a classification ▪ For details, refer to Sections 6-7-3.
	<Parameter attribute read-out> Data specified by Pr.7.35 RTEX command 1 ▪ For details, refer to Sections 7-7-1.	<Parameter attribute read-out> Parameter attribute ▪ For details, refer to Sections 6-7-4.
	<Writing to EEPROM> Data specified by Pr.7.35 RTEX command 1 ▪ For details, refer to Sections 7-7-1.	<Writing to EEPROM> 0 is returned.

\*1) When the parameter value is 16-bit length, convert it to 32-bit.

Example: When -1000, set to FFFFC18h

(Byte 15 = FFh, Byte 14 = FFh, Byte 13 = FCh, Byte 12 = 18h)

\*2) When the parameter value is 16-bit length, it is converted to 32-bit and then returned.

During process, the value (Busy = 1) is unstable.

## 6-7-1 Type code list of parameter command

Type_Code *1)		Title	Description									
Conventional	New											
000h	-	Undefined	<ul style="list-style-type: none"> <li>Do not use this Type_Code with MINAS-A5N. Command error (0031h) will be returned</li> </ul>									
001h	-	Undefined	<ul style="list-style-type: none"> <li>Do not use this Type_Code with MINAS-A5N. Command error (0031h) will be returned</li> </ul>									
-	010h	Parameter reading	<ul style="list-style-type: none"> <li>Use this to read out the parameter value from the servo driver.</li> <li>Set the parameter number (class, No.) to Index of command. <table border="1"> <thead> <tr> <th>Byte</th> <th>Title</th> <th>Description</th> </tr> </thead> <tbody> <tr> <td>10</td> <td>Index-L</td> <td>Parameter No.</td> </tr> <tr> <td>11</td> <td>Index-H</td> <td>Parameter class</td> </tr> </tbody> </table> </li> <li>Set the data specified in Pr.7.35 RTEX command setting 1 to Setting_Data of command.</li> <li>Return the readout value as Monitor_Data in the response.</li> <li>If Index is unsupported parameter number (No. or class is outside of range), command error 0032h will be returned.</li> <li>When Pr.7.35 RTEX command setup 1 is 0, and Command_Data3 is not 0, Command error (0032h) will be returned.</li> </ul>	Byte	Title	Description	10	Index-L	Parameter No.	11	Index-H	Parameter class
Byte	Title	Description										
10	Index-L	Parameter No.										
11	Index-H	Parameter class										
-	011h	Parameter writing	<ul style="list-style-type: none"> <li>Use this to write the parameter value to the servo driver.</li> <li>Set the parameter number (class, No.) to Index of command. <table border="1"> <thead> <tr> <th>Byte</th> <th>Title</th> <th>Description</th> </tr> </thead> <tbody> <tr> <td>10</td> <td>Index-L</td> <td>Parameter No.</td> </tr> <tr> <td>11</td> <td>Index-H</td> <td>Parameter class</td> </tr> </tbody> </table> </li> <li>Set the writing value to Setting_Data. Actual written value will be returned to the Monitor_Data of the response. When the parameter was set by the limited value that is different from the command value, WNG bit will be 1.</li> <li>If Index is unsupported parameter number (No. or class is outside of range) or if Setting_Data is other than 0, command error 0032h will be returned. When No. and class are within the range but not supported, command error 0032h will be returned with Setting_Data other than 0.</li> <li>When the bit 0 of Pr.7.23 RTEX function expansion setup 2 is set at 1, the command cannot be executed. And command error 0201h will be returned.</li> <li>Command error 0041h will be returned if you try to a parameter of read only attribute.</li> </ul>	Byte	Title	Description	10	Index-L	Parameter No.	11	Index-H	Parameter class
Byte	Title	Description										
10	Index-L	Parameter No.										
11	Index-H	Parameter class										
-	030h	The number read-out of the parameters in a classification	<ul style="list-style-type: none"> <li>The number of the parameters in a classification is read.</li> <li>Set the parameter class number to Index-H of command.</li> <li>Fix 0 to Index-L of command. <table border="1"> <thead> <tr> <th>Byte</th> <th>Title</th> <th>Description</th> </tr> </thead> <tbody> <tr> <td>10</td> <td>Index-L</td> <td>Fix 0</td> </tr> <tr> <td>11</td> <td>Index-H</td> <td>Parameter class</td> </tr> </tbody> </table> </li> <li>Set Data specified by Pr.7.35 RTEX command setup 1 as Command_Data3.</li> <li>When Index-L is not 0, Command error (0032h) will be returned.</li> <li>When the classification number in which a parameter does not exist is specified, 0 will be returned.</li> <li>When Index-H is outside the parameter classification number, Command error (0032h) will be returned.</li> <li>When Pr.7.35 RTEX command setup 1 is 0, and Command_Data3 is not 0, Command error (0032h) will be returned.</li> </ul>	Byte	Title	Description	10	Index-L	Fix 0	11	Index-H	Parameter class
Byte	Title	Description										
10	Index-L	Fix 0										
11	Index-H	Parameter class										

Type_Code *1)		Title	Description									
Conventional	New											
-	040h	Parameter attribute read-out	<ul style="list-style-type: none"> <li>The attribute of a parameter is read-out.</li> <li>Set the parameter number (class, No.) to Index of command. <table border="1"> <thead> <tr> <th>Byte</th> <th>Title</th> <th>Description</th> </tr> </thead> <tbody> <tr> <td>10</td> <td>Index-L</td> <td>Parameter No.</td> </tr> <tr> <td>11</td> <td>Index-H</td> <td>Parameter class</td> </tr> </tbody> </table> </li> <li>Set Data specified by Pr.7.35 RTEX command setup 1 as Command_Data3.</li> <li>When Index is outside the parameter number (No. or class), Command error (0032h) will be returned.</li> <li>When Pr.7.35 RTEX command setup 1 is 0, and Command_Data3 is not 0, Command error (0032h) will be returned.</li> </ul>	Byte	Title	Description	10	Index-L	Parameter No.	11	Index-H	Parameter class
Byte	Title	Description										
10	Index-L	Parameter No.										
11	Index-H	Parameter class										
101h	081h	EEPROM writing	<ul style="list-style-type: none"> <li>Save the parameter value to EEPROM in the servo driver. (An error might occur during processing. In this case, ERR bit will be 1 instead of command error, and retry to transmit command.)</li> <li>Set 0 to Index of command.</li> <li>Set Data specified by Pr.7.35 RTEX command setup 1 as Command_Data3.</li> <li>When Index is not 0, Command error (0032h) will be returned.</li> <li>When Pr.7.35 RTEX command setup 1 is 0, and Command_Data3 is not 0, Command error (0032h) will be returned.</li> <li>When Err. 11.0 Control power supply under-voltage protection occurs, command error (0061h) will be returned because of EEPROM accessing failure.</li> <li>When the bit 0 of Pr.7.23 RTEX function expansion setup 2 is set at 1, the command cannot be executed. And command error 0201h will be returned.</li> </ul>									

\*1) Command error (0031h) will be returned at setting up the wrong type code

#### 6-7-2 Parameter number of MINAS-A5N series

The numbers of parameters used with MINAS-A5N series are divided into type (major number) and No. (minor number).

The high byte (Index-H) of Index represents the type of parameter and the low byte (Index-L) represents the parameter No.

For example, with Pr.7.23, set it as shown in the table below.

Byte	Title	Description	Setup value (with Pr.7.23)
10	Index-L	Parameter No.	23 (=17h)
11	Index-H	Parameter class	7 (=07h)

These parameters are not compatible with those of MINAS-A4N. To prevent operation error due to incompatible parameters, parameter reading Type\_Code and parameter writing Type\_Code are changed.

Title	Type_Code	
	MINAS-A4N	MINAS-A5N
Parameter reading	000h	010h
Parameter writing	001h	011h

When Type\_Code is set to 000h or 001h, command error 0031h is returned.



## 6-7-3 Parameter number of MINAS-A5N series

The not used parameter and the manufacturer's use parameter are also contained in the parameters in a classification read by Type\_Code=030h.

## Example)

Case of Index-H=08h (When reading the parameter number of the classification 8 by soft version Ver.1.01)

Since 20 parameters (Pr8.00-Pr8.19) exist as shown in the following table, 20 (14h) is returned.

Class	No.	Title
8	00	For manufacturer's use
	01	Profile linear acceleration constant
	02	For manufacturer's use
	03	For manufacturer's use
	04	Profile linear deceleration constant
	05	For manufacturer's use
	06	Not used
	07	Not used
	08	Not used
	09	Not used
	10	Amount of travel after profile position latch detection
	11	Not used
	12	Profile return to home position mode setup
	13	Profile home position return velocity 1
	14	Profile home position return velocity 2
	15	For manufacturer's use
	16	Not used
	17	Not used
	18	Not used
	19	For manufacturer's use

- Please refer to the parameter table of 9-1 clause of Functional Specification (SX-DSC02202) for parameters and details other than classification 8.
- Since the not used parameter is not indicated to the parameter table, it is careful.

## 6-7-4 Parameter attribute of MINAS-A5N series

Attribute indicates when the changed parameter is made valid.

- A: Always valid
- B: Do not change parameter while the motor is operating or command is given.
  - If a parameter is changed while the motor is operating or command is being issued, reflecting timing is not defined.
- C: Made valid, after resetting of control power, in software reset mode of RTEX communication reset command or after execution of attribute C parameter validation mode.
- R: Made valid after resetting of control power or execution of software reset mode of RTEX communication reset command.
  - Not made valid by executing attribute C parameter validation mode of reset command of RTEX communication.
- R0: Read only and cannot be changed through normal parameter changing procedure.

The bit assignment of the parameter attribute read by Type\_Code=040h is as follows.

When an applicable bit is 1, it means being the attribute.

	bit7	bit6	bit5	bit4	bit3	bit2	bit1	bit0
Byte12	NOT_USE	(For manufacturer's use)	-	B_AT_INIT	(For manufacturer's use)	-	-	-
Byte13	PARA32BIT	-	-	B_PRM_ATB_CFG	-	-	-	READ_ONLY
Byte14	-	-	-	-	-	-	-	-
Byte15	-	-	-	-	-	-	-	-

- NOT\_USE : Not used parameter.
- B\_AT\_INIT : Made valid after resetting of control power or execution of software reset mode of RTEX communication reset command.
- B\_PRM\_ATB\_CFG : Made valid after execution of attribute C parameter validation mode.
- READ\_ONLY : Read only parameter.
- PARA32BIT : 32bit parameter (Parameter whose size is 2 bytes)

Example) Index-H=0, Index-L=8

Since Pr0.08 Number of command pulse per motor revolution is Attribute C(B\_AT\_INIT,B\_PRM\_ATB\_CFG) and 32bit parameter(PARA32BIT), "00009010h" is returned

## 6-7-5 Protecting parameter writing/EEPROM writing through RTEX

Parameter writing or EEPROM writing via RTEX can be inhibited through the setting of bit 0 of Pr.7.23 RTEX function expansion setup 2.

Attempting to access in inhibited status causes returning of command error (0201h).

Pr.7.23 bit 0	Parameter writing/EEPROM writing through RTEX
0	Enable
1	Disable (command error 0201h)

Use this function to prevent the possible problem as described below: the host controller attempts to change parameter while the setup support software PANATERM is running to adjust the gain.

## 6-8 Profile command (Command code: 17h)

Use this command when starting the operation in profile position control mode (PP) where servo driver internally generates the position command.

This command supports cyclic command only in PP mode (1h).

Set the target position (TPOS) to Command\_Data1 field and target speed (TSPD) to Command\_Data3 field.

Set the acceleration/deceleration by using parameter Pr.8.01 Profile linear acceleration constant and Pr.8.04 Profile linear deceleration constant.

Set the operation mode of profile positioning and profile homing by using Type\_Code.

For details of these profile operations, refer to 7-5.

Compatible control mode				
NOP	PP	CP	CV	CT
-	○	-	-	-

■ Main command: common to 16 byte and 32 byte mode

Byte	Command								Byte	Response							
	bit7	6	5	4	3	2	1	0		bit7	6	5	4	3	2	1	0
0	C (0)	Update_Counter		MAC-ID					0	R (1)	Update_Counter_Echo		Actual_MAC-ID				
1	TMG_CNT	17h							1	CMD _Error	17h						
2	Control_Bits							2	Status_Flags								
3								3									
4	Target_Position (TPOS) [Command unit]							L	4	Response_Data1							L
5								ML	5								ML
6								M	6								MH
7								H	7								H
8	Type_Code							8	Type_Code Echo								
9	0							9	ERR	WNG	0	Busy	PSL/NSL	NSL/PSL	NEA R	Latch_Comp 1	
10	0		Latch_Sel1				10	0		Latch_Sel1 Echo							
11	Monitor_Sel							11	Monitor_Sel Echo								
12	Target_Speed (TSPD) [Command unit/s] or [r/min]							L	12	Monitor_Data							L
13								ML	13								ML
14								M	14								MH
15								H	15								H

■ Sub-command: specific to 32 byte mode

(Not supported): Cannot be used by a sub-command. Use only with the main command.

Title	Command	Response						
Target_Position (TPOS)	<Absolute positioning mode (with Type_Code = 10h/12h)> Target position [Size]: Signed 32-bit [Unit]: Instruction unit [Setting range]: 80000000h-7FFFFFFFh (-2147483648 to 2147483647)	-						
	<Relative positioning mode (with Type_Code = 11h/13h)> Relative movement distance [[Size]: Signed 32-bit [Unit]: Instruction unit [Setting range]: 80000000h-7FFFFFFFh (-2147483647 to 2147483647)							
	<Non positioning mode> Set to 0.							
Type_Code /Type_Code_Echo	Set operation mode of profile positioning ▪ For details, refer to 6-8-1.	Echo back value of Type_Code						
Latch_Comp1	-	Complete status at latch position 1 ▪ For details, refer to 6-8-3.						
Latch_Sel1 /Latch_Sel1_Echo	<Latch positioning mode> (with Type_Code = 12h/13h)> Select trigger signal of position latch (Ch1) ▪ For details, refer to 6-8-2.	<Latch positioning mode> (with Type_Code = 12h/13h)> Echo back value of Latch_Sel1 ▪ For details, refer to 6-8-2.						
	<Other than latch positioning> Set to 0.	<Other than latch positioning> Echo back value of Latch_Sel1(=0)						
Monitor_Sel /Monitor_Sel_Echo	Select data to be returned to Monitor_Data, by using Type_Code of the monitor command (new 8-bit code for A5N). ▪ For details, refer to 6-8-3.	Echo back value of Monitor_Sel						
Target_Speed (TSPD) /Monitor_Data	Target speed [Size]: Signed 32-bit [Setting range]: - motor max. speed to motor max. speed ▪ When speed setting is in r/min, it is converted to command unit/s through internal computation and the equivalent value is limited within the range as shown below: -80000001h-7FFFFFFFh (-2147483647-2147483647) ▪ During operation of positioning system (Type_Code = 10h, 11h, 12h, 13h), minimum value of setting range is 0. [Unit]: Set by Pr.7.25 RTEX speed unit setup	Monitor data selected by Monitor_Sel ▪ For details, refer to 6-9-1.						
	<table border="1"> <thead> <tr> <th>Pr.7.25</th> <th>Unit</th> </tr> </thead> <tbody> <tr> <td>0</td> <td>[r/min]</td> </tr> <tr> <td>1</td> <td>[Command unit/s]</td> </tr> </tbody> </table>	Pr.7.25	Unit	0	[r/min]	1	[Command unit/s]	
Pr.7.25	Unit							
0	[r/min]							
1	[Command unit/s]							

## 6-8-1 Profile command Type\_Code list

Type_Code *1)	Title of profile operation mode	Description	Pr.0.01 Control mode setting					
			0: Semi-closed			1: Full-closed		
			SER INC	SER ABS		SER INC	ABZ INC	SER ABS
INC	ABS							
10h	Profile absolute positioning	Positioning to the target position (TPOS) specified by absolute position	○	○	○	○	○	○
11h	Profile relative positioning	Positioning to the target position (TPOS) specified as the relative movement distance from the current internal command position (IPOS)	○	○	○	○	○	○
12h	Profile Position latch Absolute positioning	Operation starts in latch mode and upon detecting latch trigger, performs positioning by moving from the latch position 1 (LPOS1) to the stop position with the relative distance to the stop position being specified by the parameter setting.  ▪ To the target position (TPOS), set the position (absolute position) which is used as stop position when latch trigger is not detected.	○	○	○	○	○	△ *2)
13h	Profile Position latch Relative positioning	Operation starts in latch mode and upon detecting latch trigger, performs positioning by moving from the latch position 1 (LPOS1) to the stop position with the relative distance to the stop position being specified by the parameter setting.  ▪ To the target position (TPOS), set the position which is used as stop position when latch trigger is not detected. Set the stop position by relative movement distance from the current internal command position (IPOS).	○	○	○	○	○	△ *2)
20h	Profile Continuous revolution (JOG)	Continuous revolution operation without requiring setting of target position (TPOS)	○	○	○	○	○	○
31h	Profile Homing 1	Homing operation using HOME sensor and Z phase	○	○	–	○	○	–
32h	Profile Homing 2	Homing operation using HOME sensor	○	○	–	○	○	–
33h	Profile Homing 3	Homing operation using Z phase	○	○	–	○	○	–

\*1) If Type\_Code error occurs, command error (0031h) will be returned.

\*2) Because the absolute external scale of serial communication type does not have Z-phase, Z-phase cannot be set to latch trigger signal: command error (005Ah) will be returned.

▪ ○: Supported; △: Partially supported; –: Not supported

Terms in table above	Semi-closed	Full-closed
SER_INC	20-bit incremental encoder	Serial communication type incremental external scale
SER_ABS	17-bit absolute encoder	Serial communication type absolute external scale
INC in SER_ABS	Use 17-bit absolute encoder in the incremental mode	–
ABS in SER_ABS	Use 17-bit absolute encoder in the absolute mode	–
ABZ_INC	–	ABZ output type incremental external scale

## 6-8-2 Selection of latch trigger signal for positioning profile position latch

For profile position latch absolute positioning (Type\_Code = 12h) and profile position latch relative positioning (Type\_Code = 13h) use Latch\_Sel1 to select the latch trigger signal.

Byte	Command								Byte	Response							
	bit7	6	5	4	3	2	1	0		bit7	6	5	4	3	2	1	0
10	0								10	Latch_Sel1_Echo							

	Setting value	Latch trigger signal
Latch_Sel1	0	Z phase ▪ Z phase of external scale when in full-closed control. ▪ Command error (005Ah) is returned at a serial communication type absolute external scale.
	1	Logical rising edge of EXT1
	2	Logical rising edge of EXT2
	3	Logical rising edge of EXT3
	4-8	Do not use. If it chooses, a command error (0032h) will be returned.
	9	Logical falling edge of EXT1
	10	Logical falling edge of EXT2
	11	Logical falling edge of EXT3
	12-15	Do not use. If it chooses, a command error (0032h) will be returned.

## 6-8-3 Checking latch mode complete status and latch position data

To check the end status of latch mode at the profile position latch positioning, monitor Latch\_Comp1. Latch position 1 can be checked through monitor command.

Byte	Command								Byte	Response							
	bit7	6	5	4	3	2	1	0		bit7	6	5	4	3	2	1	0
9	0								9	ERR	WNG	0	Busy	PSL/NSL	NSL/PSL	NEAR	Latch_Comp1

	Description
Latch_Comp1	0: Unlatched at latch position 1 (CH1) 1: Latched at latch position 1 (CH1)

Acquired latch position 1 data can be monitored through Monitor\_Data. Set 09h to Monitor\_Sel.

Byte	Command								Byte	Response									
	bit7	6	5	4	3	2	1	0		bit7	6	5	4	3	2	1	0		
11	Monitor_Sel								11	Monitor_Sel_Echo									
12	Command_Data3								L	12	Monitor_Data								
13									ML	13									ML
14									M	14									MH
15									H	15									H

Monitor_Sel	Monitor_Data		Description
	Title	Symbol	
09h	Latch position 1	LPOS1	Actual position of motor latched with CH1

## 6-8-4 Stop command

Profile operation can be stopped or paused by the setting of control bit (Control\_Bits).

Byte	Command							
	bit7	6	5	4	3	2	1	0
3	Hard Stop	Smooth Stop	Pause	0	SL_SW	0	EX-OUT2	EX-OUT1

Stop command	Description
Hard_Stop (Immediate stop)	<ul style="list-style-type: none"> <li>Setting this bit to 1 in profile control mode immediately stops internal command generation process and ends profile operation.</li> <li>When internal command generation process stops, In_Progress bit is set to 0. In_Progress bit varies depending on set values of Pr4.31 (Positioning complete range), Pr4.32 (Positioning complete output setup) and Pr4.33 (INP hold time). *1)</li> <li>Even if this bit is reset to 0, previous operation is not resumed. To restart, change command from 10h to 17h.</li> </ul>
Smooth_Stop (Deceleration to stop)	<ul style="list-style-type: none"> <li>Setting this bit to 1 in profile control mode causes deceleration and stop at the rate specified by Pr.8.04 Profile linear deceleration constant, ending profile operation.</li> <li>When internal command generation process stops, In_Progress bit is set to 0. In_Progress bit varies depending on set values of Pr4.31 (Positioning complete range), Pr4.32 (Positioning complete output setup) and Pr4.33 (INP hold time). *1)</li> <li>Even if this bit is reset to 0, previous operation is not resumed. To restart, change command from 10h to 17h.</li> </ul>
Pause (Temporary stop)	<ul style="list-style-type: none"> <li>Setting this bit to 1 in profile control mode causes deceleration and stop at the rate specified by Pr.8.04 Profile linear deceleration constant, suspending profile operation.</li> <li>After stopping of internal command generation process, In_Progress bit is maintained at 1. In_Progress bit varies depending on set values of Pr4.31 (Positioning complete range), Pr4.32 (Positioning complete output setup) and Pr4.33 (INP hold time). *1)</li> <li>Resetting this bit to 0 during deceleration or stopping resumes previous operation.</li> </ul>

\*1) For detailed output conditions of In\_Position bit, see Functional Specification SX-DSV02202"Section 4-2-4" of Technical Document.

## 6-8-5 Profile positioning neighborhood output (NEAR)

While the profile positioning system is operating (Type\_Code = 10h, 11h, 12h, 13h), this output indicates whether the command position is near the target position.

Byte	Command								Byte	Response							
	bit7	6	5	4	3	2	1	0		bit7	6	5	4	3	2	1	0
9	0								9	ERR	WNG	0	Busy	PSL/NSL	NSL/PSL	NEAR	Latch_Comp1

Title	Description
NEAR	<ul style="list-style-type: none"> <li>Return 1 at location near profile positioning position.</li> <li>Set the output condition by Pr.7.15 Profile positioning neighborhood range. <ul style="list-style-type: none"> <li>■ Detection range -Pr.7.15 &lt;= internal target position - internal command position (IPOS: before filter) &lt;= Pr.7.15</li> </ul> </li> </ul>

Class	No.	Attribute	parameter Title	Setting range	Unit	Description
7	15	A	Profile positioning neighborhood range	0-1073741823	Command unit	If the difference between internal target position and command position is smaller than the specified value during profile position control (PP), NEAR of RTEX communication status becomes 1.

When the latch trigger signal is detected during profile position latch absolute positioning (12h)/profile position latch relative positioning(13h), the internal target position is updated to the value shown below, not to the value (TPOS) set by the command.

Internal target position = latch position 1 (LPOS1) + Pr.8.10 Movement distance after detection of profile position latch
---

Note that, when deceleration is decreased, for example due to update of internal target position, command position may temporarily exceed internal target position, causing NEAR to turn on.



## 6-8-6 Software limit (PSL/NSL)

These bits indicate whether the actual position (APOS) exceeds the software limit range during profile position control (PP).

This status can be made valid only with profile command.

Note that servo driver only returns the status but does not perform stopping process. If stopping process is necessary, perform it from the host controller.

Byte	Command								Byte	Response							
	bit7	6	5	4	3	2	1	0		bit7	6	5	4	3	2	1	0
9	0								9	ERR	WNG	0	Busy	PSL/NSL	NSL/PSL	NEAR	Latch_Comp

Title	Description
PSL	<ul style="list-style-type: none"> <li>Return 1 when actual position (APOS) is larger than Pr.7.11 (Profile Positive side software limit value). <ul style="list-style-type: none"> <li>Detection range Pr.7.11 &lt; APOS</li> </ul> </li> <li>Use Pr.7.10 Software limit function to select Valid/Invalid.</li> </ul>
NSL	<ul style="list-style-type: none"> <li>Return 1 when actual position (APOS) is smaller than Pr.7.12 (Profile Negative side software limit value). <ul style="list-style-type: none"> <li>Detection range APOS &lt; Pr.7.12</li> </ul> </li> <li>Use Pr.7.10 Software limit function to select Valid/Invalid.</li> </ul>

Class	No.	Attribute	parameter Title	Setting range	Unit	Description
7	10	A	Profile software limit function	0-3	-	Enable or disable software limit function during profile position control (PP). Set the software limit value through Pr.7.11 (Profile Positive side software limit value) and/or Pr.7.12 (Profile Negative side software limit value). 0: Enable both software limits 1: Disable positive software limit and enable negative software limit 2: Enable positive software limit and disable negative software limit 3: Disable both software limits Note: RTEX communication status is 0 for limit signal (PSL/NSL) disabled by this parameter. It is also 0 when homing is uncompleted.
7	11	A	Profile positive side limit value	-1073741823 - 1073741823	Command unit	Set positive side and negative side software limits. When the limit is exceeded, status PSL/NSL of RTEX communication is turned on (= 1). Note: Make sure that positive side software limit > negative side software limit.
7	12	A	Profile negative side limit value	-1073741823 - 1073741823	Command unit	Note: Make sure that positive side software limit > negative side software limit.

Note that arrangement of status bits may be changed as shown below.

Class	No.	Attribute	parameter Title	Setting range	Unit	Description
7	23	B	RTEX function expansion setup 2	-32768 -32767	-	[bit 7] RTEX status bit arrangement setting for PSL/NSL 0: PSL at bit 3 and NSL at bit 2 1: NSL at bit 3 and PSL at bit 2 <ul style="list-style-type: none"> <li>For description on bits other than shown above, refer to Technical Reference, SX-DSV02202"Section 9-1", Functional Specification.</li> </ul>

## 6-8-7 Other precautions related to profile command

- Imports command argument such as Target\_Position (TPOS) and starts up when command code changed from 10h to 17h.
- In case of changing command argument and parameter set value in a state of command code 17, there may be cases where values are not reflected or error is given depending on operation status, parameter setting status and arguments to be changed as shown in the following table.

			bit 5 of Pr7.23 (non-cyclic command start-up mode) = 0 (A4N compatible mode)		bit 5 of Pr7.23 (non-cyclic command start-up mode) = 1 (Expansion mode)	
			In operation	In suspension	In operation	In suspension
Command argument to be changed	Target_Position (TPOS)	Positioning mode (Type_Code=10 – 13h)	△	△	○	△
		Other than positioning mode	–	–	–	–
	Type_Code		×	△	×	△
	Latch_sel1	Latch positioning mode (Type_Code=12h,13h)	×	△	×	△
		Other than latch positioning mode	–	–	–	–
	Monitor_Sel		△	△	○	△
Target_Speed (TSPD)		△	△	○	△	
Parameter to be changed	Pr8.01 (Profile linear acceleration constant)		*	△	*	△
	Pr8.04 (Profile linear deceleration constant)		*	△	*	△
	Pr8.10 (Movement distance after detection of profile position latch)		*	△	*	△
	Pr8.12 (Profile homing mode setting )		*	△	*	△
	Pr8.13 (Profile homing velocity1)		*	△	*	△
	Pr8.14 (Profile homing velocity 2)		*	△	*	△

- : Reflected
  - △: Not reflected by only change of value  
Can be reflected by returning command code to 10h once and by changing it to 17h.
  - \*: Not reflected
  - ×: Change is prohibited  
Err91.1 (RTEX command error protection) and command error (0140h) are generated.
  - : Invalid
- During operation (In\_Progress = 1), non-cyclic commands (except for certain homing commands) can also be executed, maintaining profile operation. However, do not change operation mode (Type\_Code and Latch\_Sel1 in profile command). Otherwise, Err.91.1 RTEX command error protection and command error 0104h will occur.

6-9 Monitor Command (Command Code: □Ah)

Use this to read out position error and overload ratio etc.

Compatible control mode				
NOP	PP	CP	CV	CT
-	○	○	○	○

■ Main command: common to 16 byte and 32 byte mode

Byte	Command								Byte	Response								
	bit7	6	5	4	3	2	1	0		bit7	6	5	4	3	2	1	0	
0	C (0)	Update_Counter		MAC-ID					0	R (1)	Update_Counter Echo		Actual_MAC-ID					
1	TMG_CNT	□Ah							1	CMD_Error	□Ah							
2	Control_Bits								2	Status_Flags								
3									3									
4									L									L
5	Command_Data1								ML	Response_Data1								ML
6									M									M
									H									H
7									H									H
8	Type Code								L	Type Code Echo								L
9	0								H	9	ERR	WNG	0	Busy				H
10									L									L
11	Index								H	Index_Echo								H
12									L									L
13									ML	Monitor_Data								ML
14	Command_Data3								M									M
									H									H
15									H									H

■ Sub-command: specific to 32 byte mode

Byte	Command								Byte	Response								
	bit7	6	5	4	3	2	1	0		bit7	6	5	4	3	2	1	0	
16	Sub_Chk (1)	0	0	0	Sub_Command_Code (Ah)				16	Sub_CMD_Err	Sub_ERR	Sub_WNG	Sub_Busy	Sub_Command_Code_Echo (Ah)				
17	Sub_Type_Code								17	Sub_Type_Code Echo								
18									L									L
19	Sub_Index								H	Sub_Index_Echo								H
20									L									L
21									ML	Monitor_Data								ML
22	Sub_Command_Data1								M									M
									H									H
23									H									H
24									L									L
25	Sub_Command_Data2								ML	Sub_Response_Data2								ML
26									M									M
									H									H
27									H									H
28									L									L
29	Sub_Command_Data3								ML	Sub_Response_Data3								ML
30									M									M
									H									H
31									H									H

Title	Command	Response
Type_Code /Type_Code Echo	Specify the monitor to be read ▪ For details, refer to Section 6-9-1.	Type_Code echo back value
Sub_Type_Code /Sub_Type_Code Echo		
Index/Index_Echo		Type_Code echo back value
Sub_Index /Sub_Index_Echo		
Command_Data3 /Monitor_Data	Data specified by Pr.7.35 RTEX command setup 1 ▪ For details, refer to Sections 7-7-1.	Specified monitor data [Size]: Signed 32-bit (Sign is dependent on the monitor data) [Unit]: Dependent on the monitor data
Sub_Command_Data1 /Sub_Moniroot_Data	Set to 0	▪ If the length of monitor data is 16 bits, it will be converted to 32-bit data before being returned. ▪ Even if the command code and command argument are stored, the monitor data will be updated to the newest value. ▪ For details, refer to Section 6-9-1.

## 6-9-1 Type code list of monitor command

Type Code *1)		Title		Index *2)	Unit	Description	Refer to						
Conventional	New												
101h	01h	Position deviation (after filtering)	PERR	0 (1,2)	Command unit	<In position control mode> Position deviation after filtering <In full-closed control mode> External scale deviation after filtering <In speed/torque control mode> Undefined Note: Although the same data is returned whether Index is 1 or 2, use Index = 0.	6-9-4						
102h	02h	Encoder resolution	-	0	pulse/r	Encoder resolution of motor connected	-						
104h	04h	Internal command position (after filtering)	MPOS	0	Command unit	Internal command position after filtering	6-9-4						
105h	05h	Actual speed	ASPD	0	Set to Pr.7.25	Motor actual speed ▪ Set the unit through Pr.7.25 RTEX speed unit setup. <table border="1" style="margin-left: auto; margin-right: auto;"> <thead> <tr> <th>Pr.7.25</th> <th>Unit</th> </tr> </thead> <tbody> <tr> <td>0</td> <td>[r/min]</td> </tr> <tr> <td>1</td> <td>[Command unit/s]</td> </tr> </tbody> </table>	Pr.7.25	Unit	0	[r/min]	1	[Command unit/s]	-
Pr.7.25	Unit												
0	[r/min]												
1	[Command unit/s]												
106h	06h	Torque	TRQ	0	0.1%	Command torque to motor	-						
-	07h	Actual position	APOS	0	Command unit	Motor actual position ▪ Position of external scale in full-closed mode	6-9-4						
-	08h	Internal command position (before filtering)	IPOS	0	Command unit	Internal command position before filtering	6-9-4						
-	09h	Latch position 1	LPOS1	0	Command unit	Motor actual position latched in CH1	6-9-4 6-5-4						
-	0Ah	Latch position 2	LPOS2	0	Command unit	Motor actual position latched in CH2	6-9-4 6-5-4						
-	0Ch	Command velocity (after filtering)	MSPD	0	Set to Pr.7.25	Command speed after filtering ▪ Set the unit through Pr.7.25 RTEX speed unit setup. <table border="1" style="margin-left: auto; margin-right: auto;"> <thead> <tr> <th>Pr.7.25</th> <th>Unit</th> </tr> </thead> <tbody> <tr> <td>0</td> <td>[r/min]</td> </tr> <tr> <td>1</td> <td>[Command unit/s]</td> </tr> </tbody> </table> ▪ Value undefined in torque control mode	Pr.7.25	Unit	0	[r/min]	1	[Command unit/s]	-
Pr.7.25	Unit												
0	[r/min]												
1	[Command unit/s]												
-	0Dh	External scale position	EXPOS	0	Pulse (External scale)	External scale position	2-5-1 2-5-2						
111h	11h	Regenerative load ratio	-	0	0.1%	Ratio of the regenerative overload protection to the alarm occurrence level	-						
112h	12h	Overload ratio	-	0	0.1%	Ratio of the actual load to the rated motor load	-						
-	21h	Logical input signal	-	0	-	Logic level of input signal	6-9-5						
-	22h	Logical output signal	-	0	-	Logic level of output signal	6-9-5						
-	23h	Logical input signal (expansion portion)	-	0	-	Logic level of input signal (expansion portion)	6-9-5						
-	24h	Logical output signal (expansion portion)	-	0	-	Logic level of output signal (expansion portion)	6-9-5						
-	25h	Physical input signal	-	0	-	Physical level of input signal	6-9-5						
-	26h	Physical output signal	-	0	-	Physical level of output signal	6-9-5						

\*1) Upon Type\_Code error, command error (0031h) will be returned.

Manufacturer will use a Type\_Code not listed above.

When a Type\_Code used by the manufacturer is set, undefined value will be returned in place of command error (0031h).

\*2) Upon Index error, command error (0032h) will be returned.

\*3) Conventional Type\_Code: Compatible with that for A4N and can be used only with main command.

New Type\_Code: Prepared for A5N and can be used with both main command and subcommand. When using with main command, set upper 4-bit to 0.

\* Although the product supports conventional Type\_Code to maintain compatibility, basically use the new Type\_Code.

Type Code		Title		Index	Unit	Description	Refer to
Conventional	New						
131h	31h	Inertia ratio	-	0	%	The ratio of load inertia to the motor's rotor inertia (equivalent of value in Pr.0.04) Inertia ratio = (load inertia/ rotor inertia) × 100	-
132h	32h	Automatic motor recognition	-	0	-	0: Invalid 1: Valid	-
133h	33h	Cause of no revolution	-	0	-	The number which shows the cause that the motor is not running.	6-9-2
134h	34h	Warning flags	-	0	-	The number which shows the cause that the motor is not running. ▪ The corresponding bit is set to 1 to activate the flag (showing warning status).	6-9-3
201h	41h	Mechanical angle (Single turn data)	-	0	pulse	The number which shows the cause that the motor is not running. ▪ The value will increase at CCW rotation. Mechanical angle = 0– (Encoder resolution - 1)  Note: When the incremental encoder is used, Monitor_Data is kept FFFFFFFF [h] until the Z-phase of the encoder is detected (1 revolution data is at zero position) after turning on of control power.	-
202h	42h	Electrical angle	-	0	-	Electrical angle of the motor ▪ The value will increase at CCW rotation. Electrical angle = 0–1FF [Hex]	-
-	43h	Multi-turn data	-	-	Turn	Multi-turn data of absolute encoder	-
-	61h	Power on cumulative time	-	-	30 min	Cumulative on-time of control power to the servo driver ▪ Because the power on time is recorded in unit of 30 minutes, a turn-on period shorter than 30 minutes is not recorded.	-
-	62h	Servo driver temperature	-	-	°C	Temperature inside the servo driver	-
-	63h	Encoder temperature	-	-	°C	Temperature inside the encoder ▪ Applicable only to 20-bit encoder: 0 for unsupported encoder.	-
-	64h	No. of inrush resistance relay operations	-	-	Cycle	Operating cycles of inrush current suppression resistor relay ▪ Saturation will occur at maximum value of 4000000h. ▪ Because the power on time is recorded in unit of 30 minutes, a turn-on period shorter than 30 minutes is not recorded.	-
-	65h	No. of dynamic brake operations	-	-	Cycle	No. of operations of dynamic brake relay ▪ Saturation will occur at maximum value of 4000000h. ▪ Because the power on time is recorded in unit of 30 minutes, a turn-on period shorter than 30 minutes is not recorded.	-
-	66h	Fan operating time	-	-	30 min	Operating time of cooling fan ▪ Because the power on time is recorded in unit of 30 minutes, a turn-on period shorter than 30 minutes is not recorded. ▪ 0 when no fan is installed.	-
-	67h	Fan life expectancy	-	-	0.1%	Percent of fan life expectancy. ▪ Because the power on time is recorded in unit of 30 minutes, a turn-on period shorter than 30 minutes is not recorded. ▪ 0 when no fan is installed.	-

Type Code		Title	Index	Unit	Description	Refer to	
Conventional	New						
-	68h	Capacitor life expectancy	-	-	0.1%	Percent life expectancy of main power source capacitor ▪ Because the power on time is recorded in unit of 30 minutes, a turn-on period shorter than 30 minutes is not recorded.	-
-	69h	Voltage across PN	-	-	V	Main power source PN voltage	-
401h	71h	RTEX cumulative communication errors	-	0	Cycle	Total number of RTEX communication errors ▪ Saturation occurs at max. value FFFFh. The count will be cleared upon restarting of servo driver or resetting of control power source.	-
411h	81h	Encoder cumulative communication errors	-	0	Cycle	Total number of communication errors between encoders ▪ Saturation occurs at max. value FFFFh. The count will be cleared upon restarting of servo driver or resetting of control power source.	-
412h	82h	Encoder cumulative communication data errors	-	0	Cycle	Total (cumulative) number of encoder communication data errors ▪ Saturation occurs at max. value FFFFh. The count will be cleared upon restarting of servo driver or resetting of control power source.	-
-	83h	External scale cumulative communication errors	-	0	Cycle	Total (cumulative) number of communication errors between external scale ▪ Saturation occurs at max. value FFFFh. The count will be cleared upon restarting of servo driver or resetting of control power source.	-
-	84h	External scale cumulative communication data errors	-	0	Cycle	Total (cumulative) number of communication errors between external scale ▪ Saturation occurs at max. value FFFFh. The count will be cleared upon restarting of servo driver or resetting of control power source.	-

## 6-9-2 Cause of no revolution

Cause of no revolution *1)	Item	Description *2)
0	No cause	Any cause of no revolution cannot be detected. Normally rotates.
1	Not in servo ready state.	<ul style="list-style-type: none"> <li>• The main power of the servo driver has not been turned on.</li> <li>• Some kind of errors is occurring.</li> <li>• Synchronization between communication and servo is not established.</li> <li>• Processing in the attribute C parameter validation mode according to the reset command.</li> </ul> And other
2	No servo-on command	The Servo On command is not given to the servo driver. <ul style="list-style-type: none"> <li>• Servo On bit of Command is 0.</li> <li>• EX_ON (external servo-on input) is allocated and the signal is off.</li> </ul> And others
3	Over-travel inhibit input active	<ul style="list-style-type: none"> <li>• Pr.5.05 = 0,1 Sequence at over-travel inhibit (other than immediate stop) and Pr.5.04 = 0 Over-travel inhibit input active; and positive drive inhibit input (POT) is ON and operation command is positive direction; or, negative drive inhibit input (NOT) is ON and operation command is negative direction.</li> <li>• Pr.5.05 = 2 Sequence at over-travel inhibit (immediate stop) and Pr.5.04 = 0 Over-travel inhibit input active; and positive drive inhibit input (POT) is ON and operation command is positive direction or negative drive inhibit input (NOT) is ON, causing the operation to stop, regardless of operation command input.</li> </ul>
4	Torque limit value too small	Valid torque limit value is set to 5% or below the rated value.
7	Too low frequency of position command input	Position command per control period is 1 command unit or smaller.
10	Instruction velocity through RTEX communication is low.	The command velocity is set to 30r/min or below.
11	Manufacturer use	—
12	Instruction torque through RTEX communication is low.	The command torque is low: 5% or below the rated torque.
13	Speed limit too low	<ul style="list-style-type: none"> <li>• Pr.3.21 Speed limit value is set to 30 r/min or lower when Pr.3.17 = 0.</li> <li>• When Pr.3.17 = 1, the speed limit of the parameter (Pr.3.21 or Pr.3.22) specified by SL_SW bit of the command is set 30r/min or lower.</li> </ul>
14	Other causes	Causes 1 to 13 are met but the No. of revolutions is below 30 r/min. (Too small commanded value, too heavy load, locking, crashing, servo driver/motor failure, etc.)

\*1) Even if any number other than 0, the motor may revolve.

\*2) The position command generation process may be interrupted by over-travel inhibit input, resulting in detection of cause 7 instead of cause 3.

## 6-9-3 Assignment of the warning flag

	bit 7	bit 6	bit 5	bit 4	bit 3	bit 2	bit 1	bit 0
Byte 12	Overload	Fun lock	Regenerative overload	-	-	-	-	Battery
Byte 13	-	-		Main power source off	Update counter	Cumulative communication error	Continuous communication error	Scale error
Byte 14	-	-	-	Scale communication	Oscillation detection	Encoder communication	Encoder overheating	Lifetime detection
Byte 15	-	-	-	-	-	-	-	-

## 6-9-4 Position information during servo off, velocity control and torque control

Position information of command system during servo off, speed control and torque control varies to follow changes in motor actual position even if the command position from the host controller is stopped.

During servo off, speed control and torque control, position deviation is undefined.



## 6-9-5 Status of input and output signals

- Logical input signal

Acquire servo driver logical input signal information.

bit7	6	5	4	3	2	1	0
Enable alarm input (E-STOP)	-	-	-	Positive direction drive inhibit input (POT)	Negative direction drive inhibit input (NOT)	-	Servo on command *1)

bit15	14	13	12	11	10	9	8
-	-	-	-	-	-	-	-

bit23	22	21	20	19	18	17	16
-	-	-	-	-	-	-	-

bit31	30	29	28	27	26	25	24
-	-	-	-	-	-	-	-

\*1) Not external servo on input status but the servo on command for servo control processing.

For details, refer to 4-2-3-1.

- Logical input signal (extended portion)

Acquire servo driver logical input signal (extended portion) information.

bit7	6	5	4	3	2	1	0
-	-	-	Near home input (HOME)	-	External latch input 3 (EXT3)	External latch input 2 (EXT2)	External latch input 1 (EXT1)

bit15	14	13	12	11	10	9	8
-	-	-	-	-	-	-	-

bit23	22	21	20	19	18	17	16
-	General purpose monitor input 5 (SI-MON5)	General purpose monitor input 4 (SI-MON4)	General purpose monitor input 3 (SI-MON3)	General purpose monitor input 2 (SI-MON2)	General purpose monitor input 1 (SI-MON1)	-	-

bit31	30	29	28	27	26	25	24
-	-	-	-	-	-	-	-

- Logical output signal

Acquire servo driver logical output signal information.

bit7	6	5	4	3	2	1	0
-	Velocity coincidence output (V-COIN)	Torque limiting output (TLC)	Zero speed detect output (ZSP)	Brake release output (BRK-OFF)	Positioning complete output (INP)	Servo alarm output (ALM)	Servo ready output (S-RDY)
bit15	14	13	12	11	10	9	8
-	-	-	-	-	-	At-speed output (AT-SPEED)	-
bit23	22	21	20	19	18	17	16
-	Velocity command on/off output (V-CMD)	Alarm clear attribute output (ALM-ATB)	Velocity limiting output (V-LIMIT)	Positioning complete output 2 (INP2)	Position command on/off output (P-CMD)	Warning output 2 (WARN2)	Warning output 1 (WARN1)
bit31	30	29	28	27	26	25	24
-	-	-	-	-	-	RTEX operation output 2 (EX-OUT2)	RTEX operation output 1 (EX-OUT1)

- Logical output signal (extended portion)

Acquire servo driver logical output signal (extended portion) information.

bit7	6	5	4	3	2	1	0
-	-	-	-	-	-	-	-
bit15	14	13	12	11	10	9	8
-	-	-	-	-	-	Communication sync complete output (SYNC_CMP)	-
bit23	22	21	20	19	18	17	16
-	-	-	-	-	-	-	-
bit31	30	29	28	27	26	25	24
-	-	-	-	-	-	-	-

- Physical input signal

Acquire the level of physical input signal to servo driver.

Logic of input signal is 0 when input is open and 1 when it is connected to COM-.

bit7	6	5	4	3	2	1	0
SI8 Input	SI7 Input	SI6 Input	SI5 Input	SI4 Input	SI3 Input	SI2 Input	SI1 Input

bit15	14	13	12	11	10	9	8
-	-	-	-	-	-	-	-

bit23	22	21	20	19	18	17	16
-	-	-	-	-	-	-	-

bit31	30	29	28	27	26	25	24
-	-	-	-	-	-	-	-

- Physical output signal

Acquire the level of physical output signal from servo driver.

Logic of output signal is 0 when output transistor is off and 1 when it is on.

bit7	6	5	4	3	2	1	0
-	-	-	-	-	SO3 Output	SO2 Output	SO1 Output

bit15	14	13	12	11	10	9	8
-	-	-	-	-	-	-	-

bit23	22	21	20	19	18	17	16
-	-	-	-	-	-	-	-

bit31	30	29	28	27	26	25	24
-	-	-	-	-	-	-	-

## 6-10 Command error (Command code: □□h)

If the servo driver cannot receive a command due to its incompleteness, it returns this response in which bit 7 of Byte 1 is 1.

■ Main command: common to 16 byte and 32 byte mode

	Command									Response										
	Byte	bit7	6	5	4	3	2	1	0	Byte	bit7	6	5	4	3	2	1	0		
Cyclic	0	C (0)	Update_Counter		MAC-ID					0	R (1)	Update_Counter Echo		Actual_MAC-ID						
	1	TMG_ CNT	Command_Code (□□h)								1	CMD_ Error (1)	Command_Code_Echo (□□h)							
	2	Control_Bits								2	Status_Flags									
	3									3										
	4									L	4									L
	5	<Command_Data1>								ML	5	<Response_Data1>								ML
	6	Dependent on cyclic command								MH	6	Default: Actual_Position (APOS)								MH
7									H	7	[Command unit]								H	
Non-cyclic	8									L	8	Error_Code								L
	9	<Command_Data2>								ML	9									H
	10	Dependent on non-cyclic command								MH	10	0								L
	11									H	11									H
	12									L	12									L
	13	<Command_Data3>								ML	13	0								ML
	14	Dependent on non-cyclic command								MH	14									MH
15									H	15									H	

■ Sub-command: specific to 32 byte mode

		Command								Response									
Byte	bit7	6	5	4	3	2	1	0	Byte	bit7	6	5	4	3	2	1	0		
16	Sub_ Chk (1)	0	0	0	Sub_Command_Code (Ah)				16	Sub_ CMD_ Err	Sub_ ERR	Sub_ WNG	Sub_ Busy	Sub_Command_Code_Ech o					
17	Sub_Type_Code								17	0									
18	Sub_Index								L	18	Sub_Error_Code								L
19									H	19									H
20									L	20									L
21									ML	21									ML
22	Sub_Command_Data1								M	22	0								M
23									H	23									H
24									L	24									L
25	Sub_Command_Data2								ML	25	Sub_Response_Data2								ML
26									M	26									M
27									H	27									H
28									L	28									L
29	Sub_Command_Data3								ML	29	Sub_Response_Data3								ML
30									M	30									M
31									H	31									H

Title	Command	Response
CMD_Error /Sub_CMD_Error	-	Return 1.
Error_Code /Sub_Error_Code	-	Command error code ▪ For details, refer to Sections 6-10-1 and 6-10-2.

## 6-10-1 Command error detection

When command error occurs, the servo driver cannot receive the command and perform required process.  
Build a system which either will not generate an error or will not enter unsafe status even if an error occurs.

## 6-10-1-1 Command error common to 16-byte and 32-byte modes

Field where error is detected		Error content	Command data Valid/Invalid (If invalid, the previous data is used.)							Error_Code *5)	Alarm
			Command code *1)		Cyclic data		Non-cyclic data				
			Byte1		Byte 2-3	Byte 4-7	Byte 8-11	Byte 12-15 (FF invalid) *8)	Byte 12-15 (FF valid) *8)		
Byte	bit	bit 6-4	bit 3-0								
0	4-0	Mismatched node address (MAC-ID) *2)	×	×	×	×	×	×	×	0011h	Err86.0
	7	C/R bit is 1 despite of command *2)	×	×	×	×	×	×	×	0012h	
1	6-4	Undefined cyclic command *2)	×	×	×	×	×	×	×	0021h	Err86.1
		Cyclic command error (except for undefined error) *7)	×	×	×	×	×	×	×	002Eh	Err91.1
	3-0	Undefined non-cyclic command *3)	○ *4)	×	○	○	×	×	○	0022h	No occurrence
2-3	-	(Unused bit is 1) No error checked									
4-7	-	Cyclic data (Command_Data1 is outside the setting range, etc. *5)	○	○	○	×	○	○	○	Code corresponding to the error ▪ See 6-10-2.	
8-11	-	Non-cyclic data (Command_Data 2) is outside the setting range. *6)	○	○	○	○	×	×	○		
12-15 (FF invalid)	-	Non-cyclic data (Command_Data 3) is outside the setting range. *6)	○	○	○	○	×	×	-		
12-15 (FF valid)	-	Non-cyclic data (Command_Data 3) is outside the setting range. *6)	○	○	○	○	○	-	×		

\*1) Even if command code of byte 1 is invalid, the same value will be echo-backed in response.

\*2) Command error (0021h) will be returned if cyclic command (Byte 1, bits 6-4) is not defined; command error (0011h) will be returned if node address does not match; command error (0012h) will be returned if C/R bit is 1. These cause unsafe condition due to lack of cyclic transfer: if error condition lasts for specified period, Err86.1 (RTEX cyclic data error protection 2) generates an alarm.

\*3) Command error (0022h) will be returned when cyclic command (bits 6 to 4 at Byte 1) is complete and non-cyclic command (bits 3 to 0 of Byte 1) is not defined.

\*4) Only cyclic command (bits 6 to 4 at Byte 1) will be valid when non-cyclic command (bits 3 to 0 of Byte 1) is not defined.

\*5) When cyclic data (Byte 4 to 7) is outside the setting range, the command error (0033h) will occur and the previous value will be used for operation. If previous cyclic command (Byte 1, bits 6-4) was different, causing the previous value undefined, set the value to 0.

- \*6) When non-cyclic data (byte 8 to 15) is abnormal, error code corresponding to the error content will be returned. For details of error code, refer to 6-10-2.
- \*7) Command error (002Eh) will be returned if the defined cyclic command (Byte 1, bits 6-4) is not correctly received. This causes unsafe condition due to lack of cyclic transfer and Err91.1 (RTEX command error protection) generates alarm.
- \*8) “FF invalid” means that Command\_Data3 feedforward is invalid and “FF valid” means feedforward is valid.

## 6-10-1-2 Command error in 32-byte mode

Field where error is detected		Error content	Subcommand data – valid ○/invalid × (If invalid, use the previous command.)					Sub_Error_Code *5)	Alarm
			Sub_Chk	Subcommand code *1)	Subcommand data				
Byte	bit		Byte16		Byte17 –23	Byte24 –27	Byte28 –31		
			bit7	bit 3–0					
16	7	Sub_Chk bit is 0 in 32-byte mode. *2)	×	×	×	×	×	0012h	Err86.0
	3–0	Subcommand is undefined. *3)	○	×	×	○	○	0022h	
17–23	-	Subcommand data (Sub_Type_Code, Sub_Index, Sub_Command_Data1) is outside the setting range, etc. *5)	○	○	×	○	○	Code corresponding to the error	No occurrence
24–27	-	Feedforward data 2 (Sub_Command_Data2) is outside the setting range. *4)	○	○	○	×	○	0034h	
28–31	-	Feedforward data 3 (Sub_Command_Data3) is outside the setting range. *4)	○	○	○	○	×		

\*1) Even if the subcommand code of Byte 16 is invalid, the value is echoed back in response.

\*2) When Sub\_Chk bit is 0, subcommand error (0012h) will be returned. This is interpreted as whole command (Bytes 0–31) in 32-byte mode is incorrect, and if error condition lasts for predetermined period, Err86.0 (RTEX cyclic data error protection 1) causes an alarm. And when subcommand error (0012h) will be returned, main command cannot execute required process.

\*3) Even if subcommand (Byte 16, bits 3–0) is undefined, feedforward data 2/3 (Bytes 24–31) are made valid.

\*4) When feedforward data is outside the setting range, command error (0034h) is generated and the previous value is used for operation.

\*5) When the value of subcommand data (Bytes 17–23) is not correct, corresponding Sub\_Error\_Code will be returned. For details of any other Sub\_Error\_Code, see 6-10-2.

## 6-10-2 List of command error code

Category	Error_Code	Cause
Command header related	0011h	• Mismatched node address (MAC-ID)
	0012h	• C/R bit is 1 despite of command • Sub_Chk is 0 in 32-byte mode.
Command code, control mode related	0021h	• Cyclic command is not defined
	0022h	• Non-cyclic command is not defined (when cyclic command is normal) • Combination error of control mode and non-cyclic command. • Subcommand is undefined in 32-byte mode.
	002Eh	• Combination of communication cycle. semi-closed/full-closed, 16/32-byte mode and control mode is not correct. • Control mode has been changed by less than 2 ms. • Control mode has been changed during profile position latch positioning/profile homing (Type_Code = 12h, 13h, 31h, 32h, 33h) operation. • Control mode has been changed during execution of non-cyclic command (Busy = 1). • Run the home return command (□4h) Type_Code=1□h/2□h during the velocity control (CV)/ torque control (CT)
Argument related	0031h	• Type_Code/Sub_Type_Code is not defined.
	0032h	• Non-cyclic data/subcommand data other than Type_Code/Sub_Type_Code is out of setup range.
	0033h	• Cyclic data (command_data1) is out of setup range
	0034h	• Feedforward data (Command_Data3, Sub_Command_Data2/3) is out of setup range.
Not executable 1 (general)	0041h	• Write access is attempted to read only media.
	0042h	• Alarm clear command is executed while an alarm that cannot be cleared and no warning is issued.
	0043h	• External scale error clear command is executed when not in full-closed control mode or no external scale error is detected.
	0045h	• In servo on state, reset command is executed in attribute C parameter validation mode.
	0046h	• After deceleration and stop according to the drive inhibit input (POT/NOT), direction command POT/NOT is applied. • During deceleration according to the drive inhibit input (POT/NOT), a profile operation (except for Type_Code = 31h, 32h, 33h) is started.
Not executable 2 (Related to return-to-home)	0051h	• Return-to-home command, multi-turn clear, is executed while the encoder is in the incremental mode.
	0052h	• During cyclic position control (CP) (* including full-closed control) in absolute mode, Type_Code = 1□h of homing command(□4h) has been executed. • During profile position control (PP) (* including full-closed control) in absolute mode, profile homing has been executed.
	0053h	• During cyclic position control (CP) (* including full-closed control) in absolute mode, actual position set/command position set (Type_Code = 21h, 22h) of homing command (□4h) have been executed.
	0055h	• Return-to-home command, multi-turn clear, is executed while in the full-closed control mode.
	0056h	• Return-to-home command, multi-turn clear, is executed while in the servo-on condition.
	0057h	• Return-to-home command, Type_Code = 1□h, is executed while in the servo-off condition.
	0058h	• While the external input is not assigned to the latch correct terminal, Type_Code is executed by using the external input as a trigger.
	0059h	• During profile position latch positioning/profile homing (Type_Code = 12h, 13h, 31h, 32h, 33h), homing command (□4h) has been executed. • During profile positioning/profile continuous revolution (Type_Code = 10h, 11h, 20h) homing command (□4h) of initialization mode (Type_Code=1□h, 31h) has been executed.
005Ah	• Z phase is set to latch trigger signal despite absolute external scale.	
Not executable 3 (related to hardware factor)	0061h	• “EEPROM writing” is not permitted because of under voltage of the control power
Not executable 4 (in process)	0101h	• In processing the previous command
	0102h	• Command is not permitted to be accepted because the servo driver is accessing to the encoder now
	0103h	• Command is not permitted to be accepted because the servo driver is accessing to the external scale now
	0104h	• Type_Code has been changed while operating under profile position control (PP).
Not executable 5 (access inhibit)	0201h	• Command is not permitted to be accepted because parameter writing or writing to EEPROM is inhibited now • Write parameter command or write EEPROM command is issued while bit 0 of Pr.7.23 RTEX function expansion setup 2 is set at 1.



6-11 Communication Error (Command code: □□h/ Response code: FFh)

This response will be returned when the communication error (CRC error) has been detected by the servo driver. Then the servo driver continues controlling based on the previously received command.

	Byte	Command								Byte	Response								
		bit7	6	5	4	3	2	1	0		bit7	6	5	4	3	2	1	0	
Cyclic	0	C (0)	Update_Counter		MAC-ID				0	R (1)	Update_Counter Echo		Actual_MAC-ID						
	1	TMG_ CNT	Command_Code (□□h)								1	FFh							
	2	Control_Bits								2	Status_Flags								
	3									3									
	4	<Command_Data1> Dependent on cyclic command								L	4	<Response_Data1> Default: Actual_Position (APOS) [Command unit]							
	5									ML	5								
	6									MH	6								
7	H									7									
Non-cyclic	8	<Command_Data2> Dependent on non-cyclic command								L	8	0							
	9									ML	9								
	10									MH	10								
	11									H	11								
	12	<Command_Data3> Dependent on non-cyclic command								L	12	0							
	13									ML	13								
	14									MH	14								
15	H									15									

■ Sub-command: specific to 32 byte mode

Byte	bit7	Command								Byte	Response							
		6	5	4	3	2	1	0	bit7		6	5	4	3	2	1	0	
16	Sub_ Chk (1)	0	0	0	Sub_Command_Code (Ah)				16	1	0	0	0	Fh				
17	Sub_Type_Code								17	0								
18	Sub_Index								L	18	0							
19									H	19								
20	Sub_Command_Data1								L	20	0							
21									ML	21								
22									M	22								
23									H	23								
24	Sub_Command_Data2								L	24	Sub_Response_Data2							
25									ML	25								
26									M	26								
27									H	27								
28	Sub_Command_Data3								L	28	Sub_Response_Data3							
29									ML	29								
30									M	30								
31									H	31								

Title	Command	Response
Byte1	–	Return FFh
Byte6	–	Return 8Fh

## 7. Operation

### 7-1 Cyclic position control (CP) operation

When the cyclic command (Byte 1, bits 6–4) is 2h while in the semi-closed or full-closed control mode and in servo-on condition (Servo\_Active: response Byte 2, bit 7 is 1), perform positioning operation according to the given command position (absolute position: Bytes 4–7).

You have to pay attention to the following.

#### 7-1-1 Command follow-up process (command position at servo-off)

For the cyclic positioning (CP), position command is given as absolute position.

Therefore, if the actual position is changed by an external force, the position will return back to the command position upon the next servo-on if the command position is kept. This operation may cause Err. 27.7 Command error protection or Err. 26.0 Over-speed protection in certain condition. Do not apply the movement command during servo-on, even if the direction is drive inhibit input.

To assure safety, when servo is off (Servo\_Active = 0), be sure to set the actual position value read from the servo driver to the command position (command position follows up the actual position).

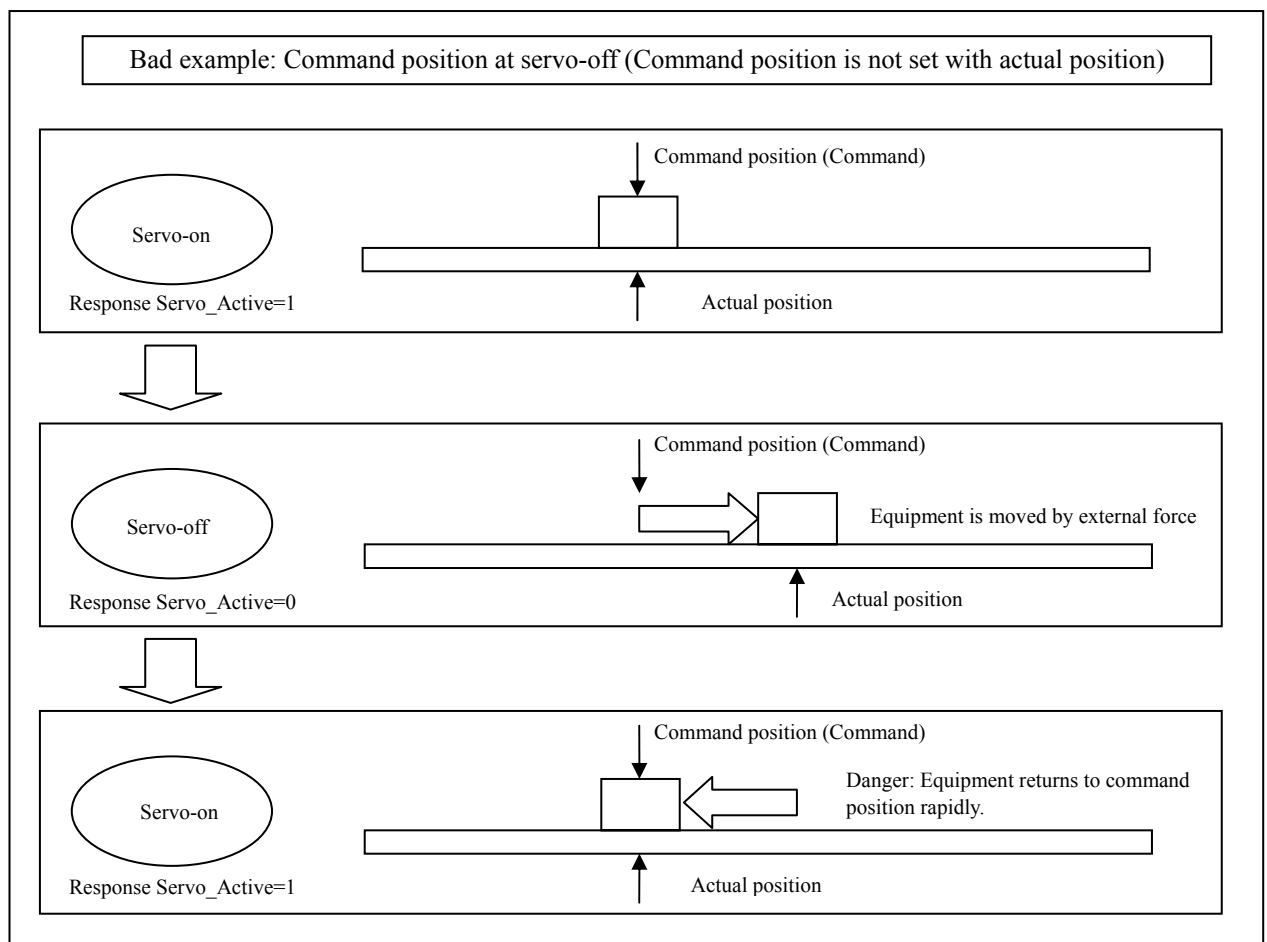

### 7-1-2 Prohibited matter of NOP command (0□h)

NOP command (0□h) is designed to be used for transient transmission while “the data to be transmitted is not yet prepared” due to processing timing problem until network is established. Therefore, try to transmit regular command e.g. 20h that specifies control mode, as soon as possible and never try to transmit NOP, and not to try to retransmit NOP.

If NOP command is transmitted while the motor is running in the cyclic positioning (CP) operation, the servo driver controls at the command position determined by the previously received command, and the cycle is unchanged as if the stop command is received. Never transmit NOP command which causes unstable operation.

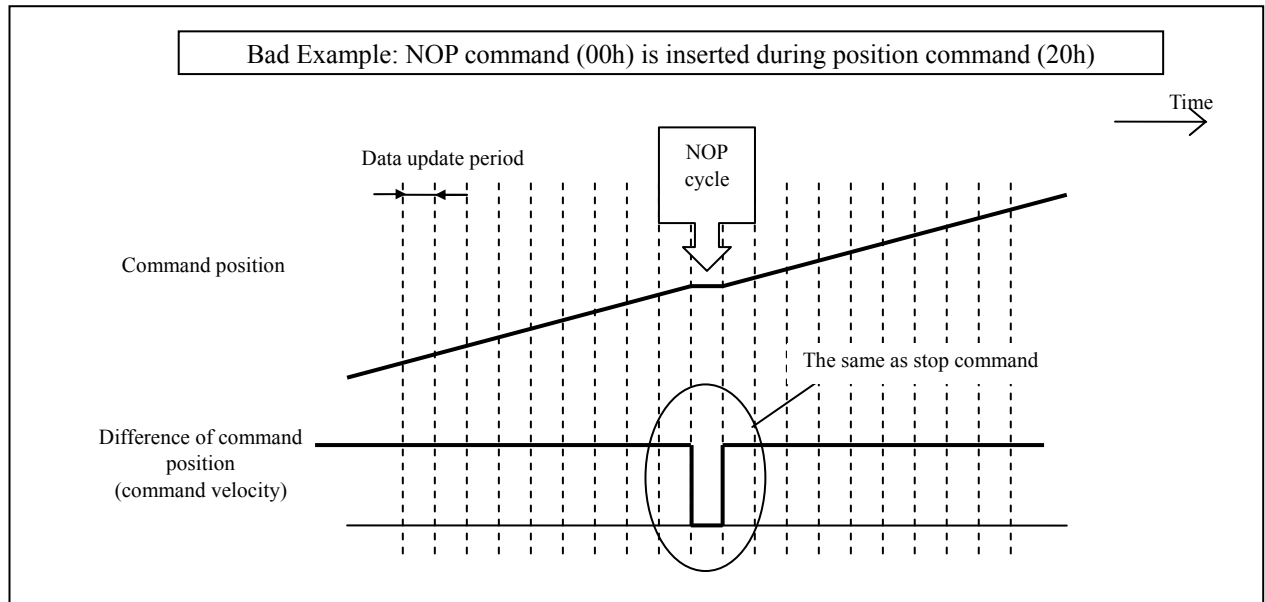

### 7-1-3 Command position upon communication error

If communication error (CRC error, missing data, cyclic data error) occurs during CP control, control the command position at the estimated position.

## 7-1-4 Variations in command position during command updating period

### 7-1-4-1 Limiting variations in command position

When applying the movement command, make sure that variations in command position during command updating period will not exceed the motor maximum speed.

Allowable input movement command value of servo driver (variations of command position during 1 s multiplied by the electronic gear ratio) is 400 M pulses/s.

The movement command should not cause variations that may exceed the smaller one of these limits.

If a variation of command position during communication period is too large, Err. 27.4 Command error protection will be activated.

### 7-1-4-2 Wrap rounding command position

If a variation of command position during communication period has exceeded 7FFFFFFh, wraparound process starts.

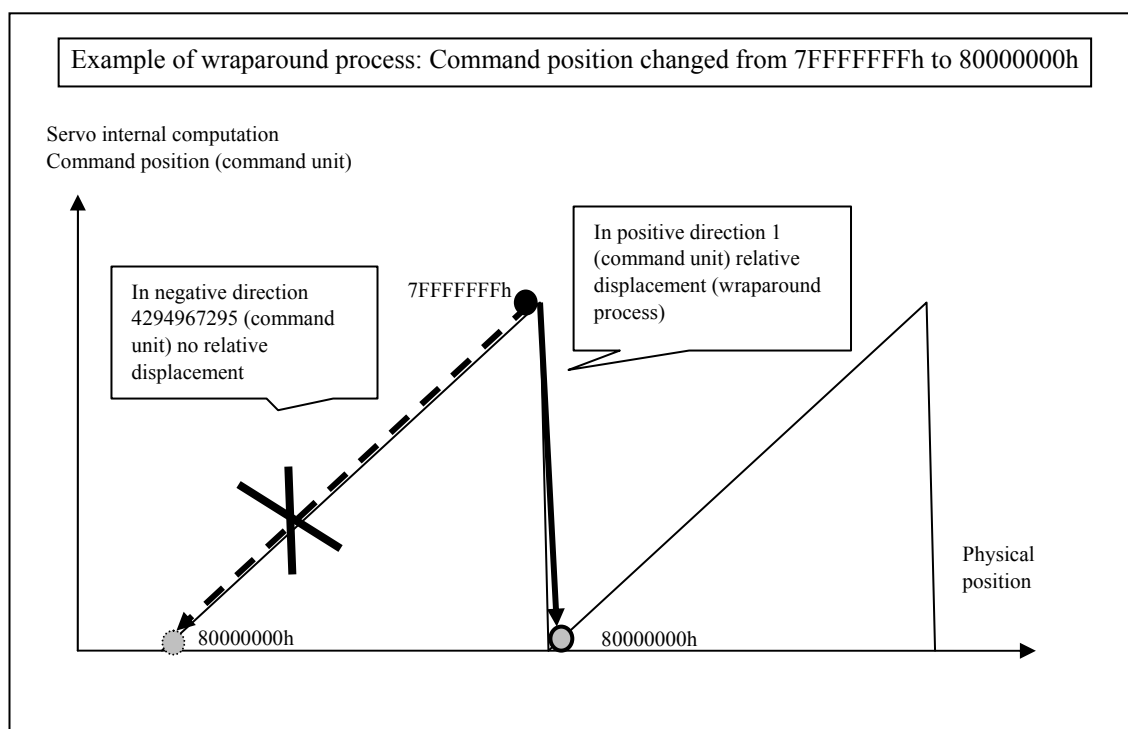

### 7-1-4-3 Clearing position deviations

When clearing position deviations from the host controller, read the actual position (APOS) and set command position to the value so that actual position (APOS) becomes equal to command position (CPOS).

Note that, as in the case of 7-1-4-1, change the command position (CPOS) gradually by dividing the command updating period in several sub-periods so that variations in command position will not exceed the limit.

## 7-2 Homing operation

When using the unit in incremental mode, homing is required before positioning after power up, software reset or execution of attribute C parameter validating mode.

With MINAS-A5N, the following return-to-home sequences can be used.

Sequence	Description
Cyclic homing	The host controller controls the return-to-home sequence in cyclic position control (CP) mode.
Profile homing	The servo driver controls the return-to-home sequence in profile position control (PP) mode.

For profile homing, refer to 7-5.

Note: Return-to-home (except for multi-turn data clear of absolute encoder) cannot be started in the velocity/torque control mode.

Switch to the cyclic position control (CP) mode or profile position control (PP) mode and start the homing operation and then return back to the previous control mode.

## 7-2-1 Normal return-to-home sequence in cyclic position control (CP) mode

[Type\_Code: 011h-01Dh]

The figure below shows the return-to-home sequence using the trigger signal (logical rising or falling edge of sensor or Z-phase).

Initialize the position information so that Homing\_Ctrl bit is 1 and trigger detection position is zero. When Homing\_Ctrl bit is 0, the position information is not initialized upon detecting of the trigger signal.

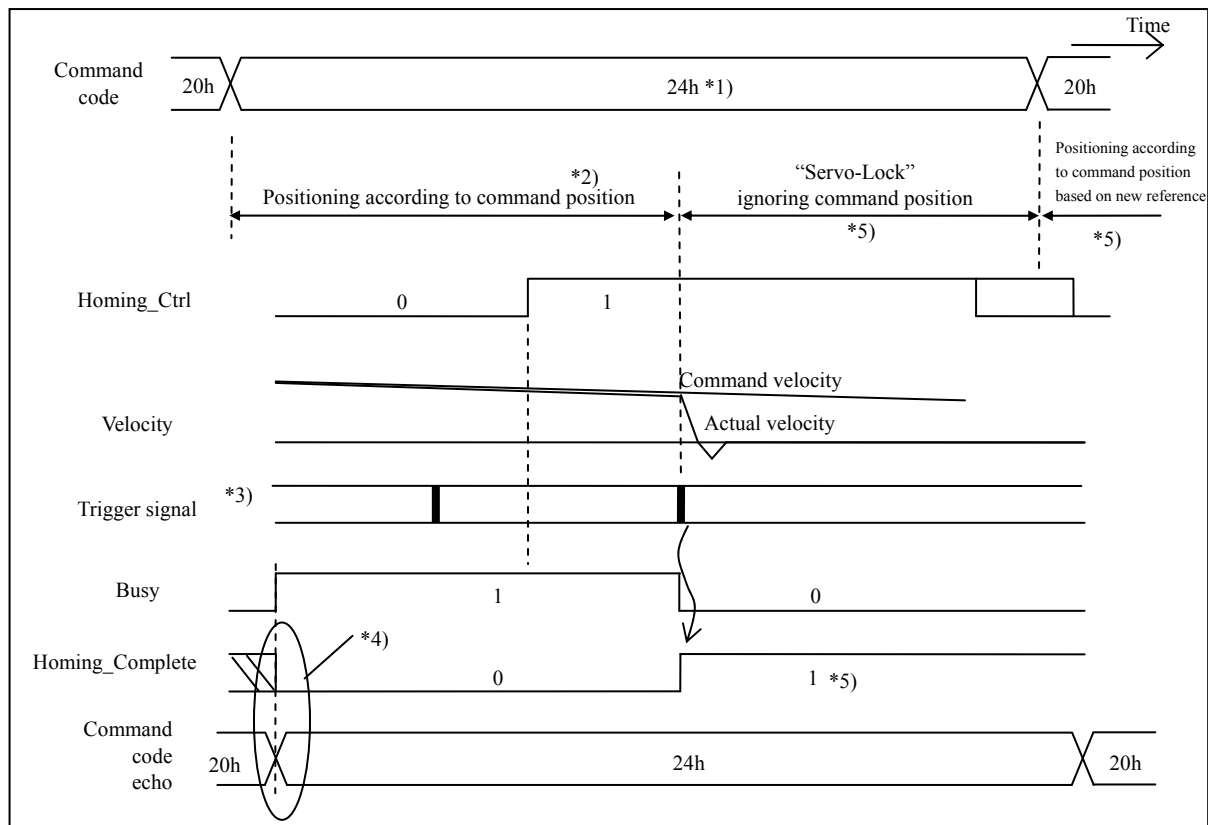

- \*1) When command code (24h) is changed to normal command (20h), homing process can be paused even when Busy = 1. Even if Pr.7.23, bit 5 = 1 (start upon changing of command code and command argument), the normal command (20h) is required to pause the homing process.
- \*2) In the incremental mode, internal command position and actual position are at 0 (home position) at power up. Until homing process completes (home position is set by trigger signal), apply the command position with reference to this 0 (home position).
- \*3) Using Type\_code, select the logical rising or falling edge of the sensor or Z-phase as the trigger signal.
- \*4) Homing complete bit will be 0 when Homing command is accepted. Note that it is 0 at power-up until homing is completed. However, if the homing is started with Homing\_Ctrl = 1 at communication cycle 0.5 ms or more and then the trigger signal is immediately detected, Homing\_Complete will not be set to 0 but set to 1 after the completion of the process at the first response. The homing process is successfully completed when no command error is detected, echo back value is returned and Homing\_Complete = 1.
- \*5) Homing complete bit will be 1 after homing is completed. While the command code is holding 24h after Homing\_Complete bit switched to 1, the servo driver will ignore the command position and will stop the motor (servo-lock) at detected home position. Note that during feedforward the value remains valid. If this causes a problem, keep feedforward value at 0 during homing process. During the process, be sure to set the command position to 0 (home position). When command code is started with normal command (20h) or another command, operation will be started by a command according to the new reference.

## 7-2-2 Sequence of actual position/command position setup

[Type\_Code: 021h, 022h]

The figure below shows the sequence in which no trigger signal is used and at a position, actual position or command position is set to Setting\_Data (Bytes 12–15).

During this operation, Homing\_Ctrl bit is not used.

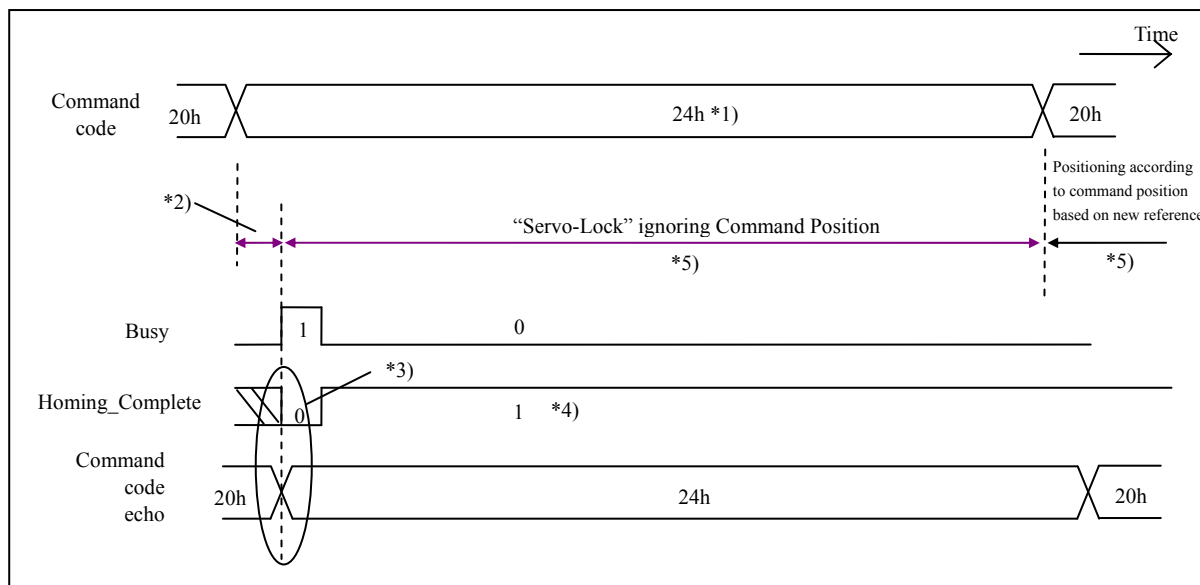

\*1) When command code (24h) is changed to normal command (20h), homing process can be paused even when Busy = 1. Even if Pr.7.23, bit 5 = 1 (start upon changing of command code and command argument), the normal command (20h) is required to pause the homing process.

\*2) Do not change command position (byte 4–7) to prevent a trouble.  
(You must set the actual position/command position when the motor is not rotating.)

\*3) Homing\_Complete bit will be 0 when Homing command (actual position/command position set) is accepted. Note that it is 0 at power-up until homing is completed. However, if the communication cycle is 0.5 ms or more, Homing\_Ctrl will not be set to 0 but set to 1 after the completion of process upon reception of the first response. The homing process is successfully completed when no command error is detected, echo back value is returned and Homing\_Complete = 1.

\*4) <Actual position setup>

The actual position is set to the value of Setting\_Data (Bytes12–15) and the command position in the servo driver is also set to this value, the position deviation becomes 0.

Position information after operation
Actual position = command position = setting value (Setting_Data)
Position deviation = 0

<Command position setup>

The command position in the servo driver is set to the value of Setting\_Data (Bytes12–15) of the command, and the actual position is set to the command position after setup minus position deviation value. The deviation is held.

Position information after operation
Internal command position = setting value (Setting_Data)
Actual position = internal command position (value after setup as shown above) – position deviation

Homing complete bit will be 1 after homing (actual position/command position setup) is completed.

- \*5) At the time Homing\_Complete bit is set to 1, the servo driver will ignore the command position and will stop the motor (servo-lock) at detected home position while command code is held to 24h.  
Note that during feedforward the value remains valid. If this causes a problem, keep feedforward value at 0 during homing process.

When setting actual position, during this period, be sure to change the command position in the command to the actual position set. At the time the command code starts the normal command (20h) or another command, the driver will operate according to the command based on the new reference.



## 7-2-3 Example of cyclic homing operation

Example	Reference of homing	Method
1	Combination of sensor signal (HOME) and Z-phase of the encoder	Control the motor velocity with observing the sensor signal level, and operate Homing_Ctrl bit.
2	Sensor signal (EXT1)	
3	Z-phase of the encoder	Operate Homing_Ctrl bit
4	Mechanical stopper	Set up a smaller torque limit in advance, and execute "actual position set" when torque limited bit becomes 1 for a given length of time.

Note 1: When performing return-to-home by specifying the drive inhibit input (NOT/POT) as the reference home position, be sure to set Pr.5.04 Over-travel inhibit input setup to 1 to disable the over-travel inhibit input. Otherwise, Err. 38.2 Drive inhibit input protection 3 will occur.

Note that even if the inhibit input is disabled, the driver receives the signal and can use it as home reference signal.

Note 2: When performing home offset, do not use the actual position set but use the command position set. The actual position set may produce a deviation equal to the position deviation.

## 7-2-3-1 Example of cyclic homing operation 1

Below shows an example of return-to-home operation in the cyclic position control (CP) mode using the combination of sensor signal (HOME) and Z-phase of the encoder. In this example, the first encoder Z-phase after passing the sensing area of HOME sensor (position where one revolution data is zero) is the home.

- 1) Set Type\_Code to Z-phase (011h) of the encoder and set Homing\_Ctrl bit to 0, and then change normal command (20h) to homing command (24h).  
Hold homing command (24h) until homing process completes.
- 2) Execute the positioning to rotate the motor at 1st velocity according to command position, which is based on the position at power-up.
- 3) Slow down the command velocity (2nd velocity) when the rising edge of HOME is detected with HOME bit of response.
- 4) Set Homing\_Ctrl bit to 1 when the falling edge of HOME is detected.
- 5) When the servo driver detects Z-phase of the encoder, it will set Homing\_Complete bit to 1, ignore command position and stop the motor (servo-lock) at home position (single turn data is zero).  
Note that during feedforward the value remains valid. If this causes a problem, keep feedforward value at 0 during homing process.
- 6) After confirming that Homing\_Complete bit has become 1, set Homing\_Ctrl bit to 0, and then set 0 (home position) to command position.
- 7) Change the command code to the normal command (20h).  
Then, positioning will start according to the new reference. Therefore, be sure to perform step 6) before changing the command code to the normal command.

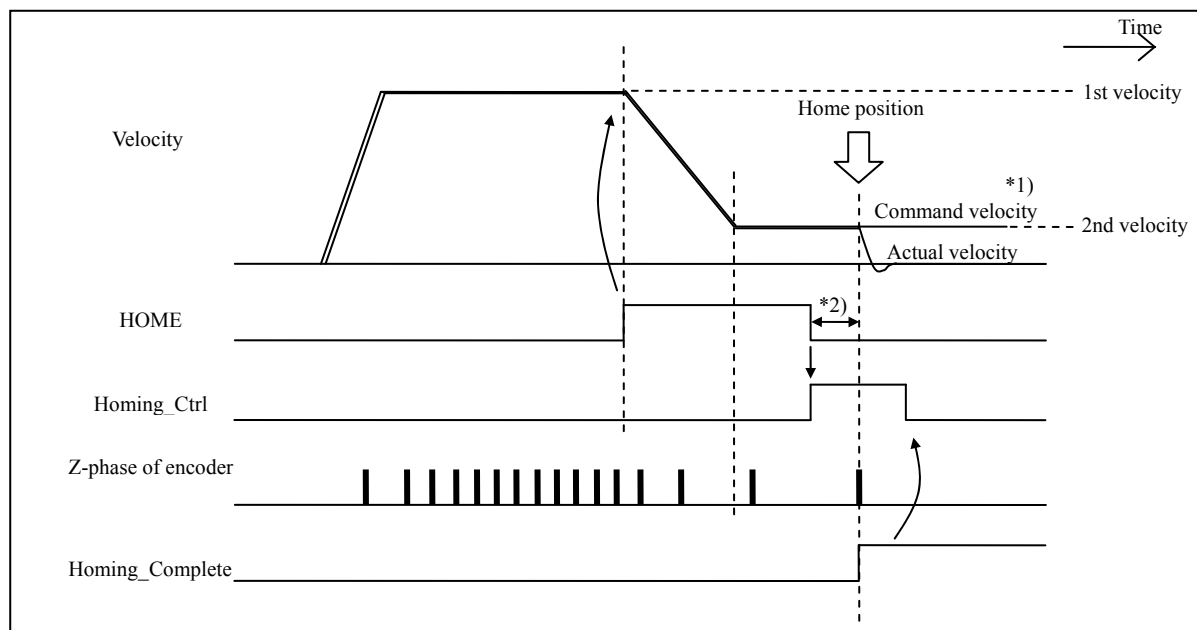

- \*1) Command velocity is differences of command position for the command update cycle. (It is internal operation value of the servo driver.)
- \*2) If the falling edge of HOME is close to Z-phase of the encoder, the delay of detecting HOME may make differences of a single turn between the detected home position and the proper home position. Install the motor at the position where Zero position of the encoder will deviate with 180 degrees (half-turn) at the mechanical angle from the falling edge of HOME.  
(In full-closed control, may make differences of Z phase and position.)  
The Z-phase of the encoder (position at which single turn data is zero) can be checked by using the following method.

semi-closed control

Method 1: Set parameter, Pr.7.00, "LED display" to 1 to display the mechanical angle on 7-segment LED, and check the zero position of the encoder where the value is 0.

Method 2: Read out the mechanical angle by monitor command, and check the zero position of the encoder where response value is 0.

Full-closed control

serial communication typ use of incremental external scale

method: Set the parameter Pr7.00 (Display on LED) to 7.

When Z phase counter is displayed, the display where this signal changed.

AB phase output type use of incremental external scale

method: Check the original signal of Z phase, and the position where the signal changed.

## 7-2-3-2 Example of cyclic homing operation 2

Below shows an example which defines the logical rising edge of EXT1 sensor in the cyclic position control (CP) mode as the home.

- 1) Set Type\_Code to logical rising edge of EXT1 sensor (018h) and set Homing\_Ctrl bit to 0, and change normal command (20h) to return-to-home command (24h). Hold the return-to-home command (24h) until the return-to-home operation completes.
- 2) Execute the positioning (at 1st velocity) according to command position, which is based on the position at power-up.
- 3) When the logical falling edge of EXT1 sensor is detected (check EXT1 bit of the response), stop positioning and set Homing\_Ctrl bit to 1. Then, reverse the rotation (2nd speed).
- 4) When the servo driver detects the logical rising edge of EXT1 sensor, set Homing\_Complete bit to 1 and execute servo-lock at home position by ignoring command position.  
Note that during feedforward the value remains valid. If this causes a problem, keep feedforward value at 0 during homing process.
- 5) After confirming that Homing\_Complete bit has become 1, set Homing\_Ctrl bit to 0, and then set 0 (home position) to command position.
- 6) Change the command code to the normal command (20h).  
Then, positioning will start according to the new reference. Therefore, be sure to perform step 5) before changing the command code back to the normal command.

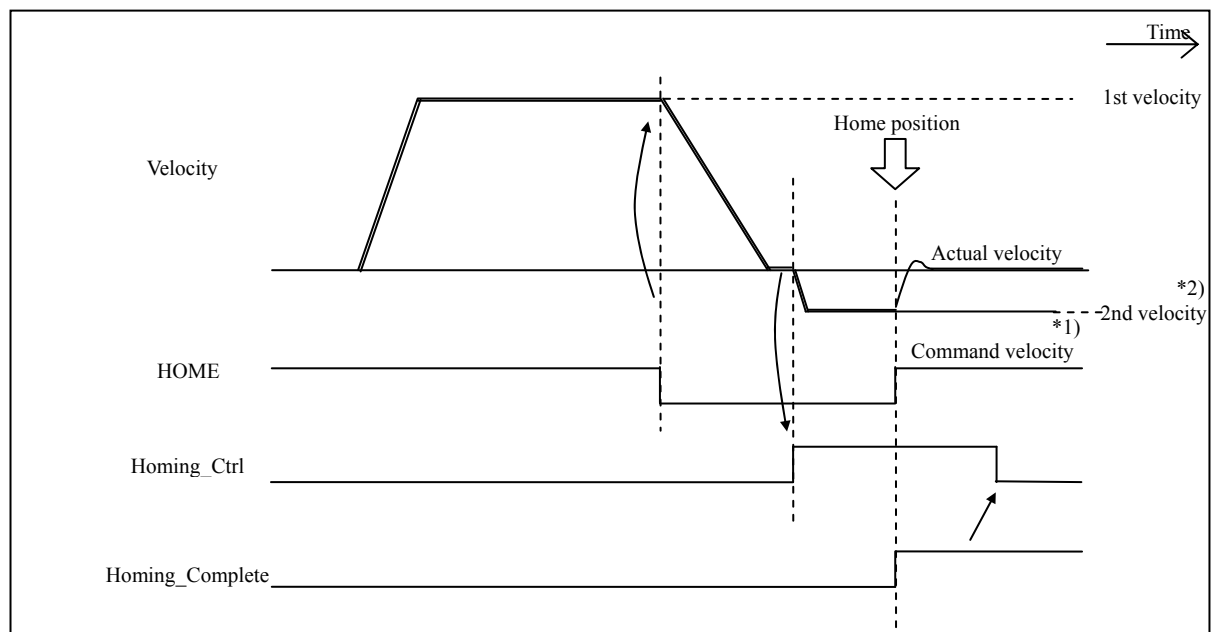

\*1) Command velocity is the differences of command position for the command update cycle. (It is internal operation value of the servo driver.)

\*2) Set up the 2nd Velocity as slow as possible.

Noise filtering process in the servo driver is executed when capturing sensor signals. This process causes the detection delay. To minimize this delay, correction process is installed which will degrade the home position detection precision if 2nd speed is set too high.

If you need higher accuracy, use the method of using the Z-phase of the encoder, and refer to “Example of cyclic homing operation 1” on the previous page.

When the trigger position is detected at a higher speed, especially with excessively low electronic gear ratio, e.g. 1/1000, wraparound of the detection position will occur upon reverse conversion to command unit, causing incorrect detection of the latch position. Latch trigger signal should be detected at the lowest possible speed.

## 7-2-3-3 Example of cyclic homing operation 3

Below shows an example of return-to-home operation in the cyclic position control (CP) mode using the Z-phase (zero position of single turn data) as the home.

- 1) Set Type\_Code to Z phase (011h), set Homing\_Ctrl bit to 1, and then change from normal command (20h) to return-to-home command (24h).  
Hold the return-to-home command until the homing process completes.
- 2) Execute the positioning according to command position, which is based on the position at power-up.
- 3) When the servo driver detects Z-phase of the encoder, it will ignore command position and stop the motor (servo-lock) at detected home position (Z-phase). Then it will set Homing\_Complete bit to 1.  
Note that during feedforward the value remains valid. If this causes a problem, keep feedforward value at 0 during homing process.
- 4) After confirming that Homing\_Complete bit has become 1, set Homing\_Ctrl bit to 0, and then set 0 (home position) to command position.
- 5) Change the command code back to normal command (20h).  
Then, positioning will start according to the new reference. Therefore, be sure to perform step 4) before changing the command code back to the normal command.

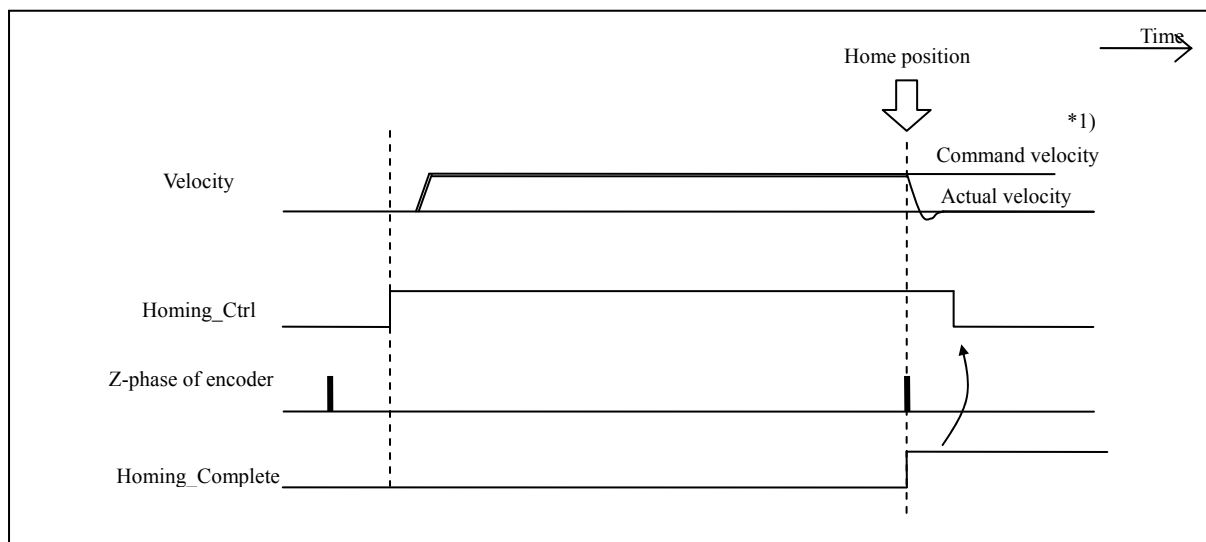

- \*1) Command velocity is the differences of command position for the command update cycle. (It is internal operation value of the servo driver.)

## 7-2-3-4 Example of cyclic homing operation 4

Below shows an example of return-to-home operation in the cyclic position control (CP) mode using the mechanical stopper.

- 1) Lower the torque limit value with using parameter command (26h) or TL SW bit of command.  
Note: For setting the torque limit value, see section 4-2-3-3.
- 2) Execute the positioning according to command position, which is based on the position at power-up. At this time, lower Command Velocity for safety.
- 3) Actual velocity will be 0 when the slider hit the stopper, and the status will show the torque limited (torque limited bit will be 1).
- 4) After verifying that the torque limited status continued for specified period ( $t_1$ ), switch the command from normal (20h) to return-to-home command (24h). Set Type\_Code to actual position set (021h) and setting position (Byte 12–15) to 0 (or desired value). Do not change the command position.
- 5) When the process of actual position set has completed in the servo driver, the driver will ignore the value of command position and stop the motor (servo-lock) at the setup position. Then it will set homing complete bit to 1.  
Note that during feedforward the value remains valid. If this causes a problem, keep feedforward value at 0 during homing process.
- 6) After confirming that homing complete bit has become 1, then set the command position to the set actual position.
- 7) Change the command code back to normal command (20h).  
Then, positioning will start according to the new reference. Therefore, be sure to perform step 6) before changing the command code back to the normal command.
- 8) Bring the torque limit value to the previous value.

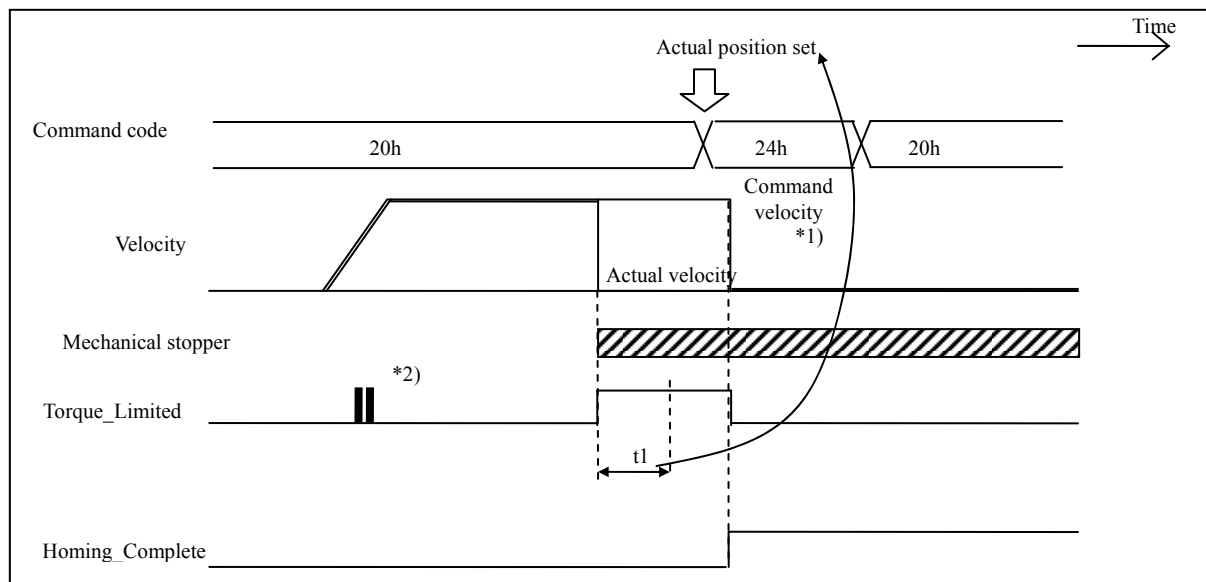

- \*1) Command velocity is the differences of command position for the command update cycle. (It is internal operation value of the servo driver.)
- \*2) Torque limited bit may be 1 even if the slider does not hit the stopper since the torque limit is lowered. Therefore, adjust  $t_1$  to avoid mis-detecting.  
Note that position deviation error (Err. 24.0) might occur when  $t_1$  is too large.

7-2-4 Initialization of the absolute encoder

Homing operation is not necessary with the absolute encoder at the position control mode (except when using the absolute encoder as the incremental mode). However, it is necessary to clear “Multi-turn data” at the first start up of the machine after installing the battery.

7-2-4-1 Absolute data

There are 2 types of data which are read out from the absolute encoder (17 bits/r), “Single-turn data” which shows the position of motor’s rotation within a single turn, and “Multi-turn data” which counts each single turn. This Multi-turn data will be backed up by a battery since this is an electrical counter.

Both data have a polarity to increase in the direction of CCW.

You can select whether Err. 41.0, “Absolute encoder counter overflow” will be generated or not when Multi-turn data has overflowed, with the parameter, Pr.0.15 “Absolute encoder set up”.

	Back up at power off	Data width	+/- Sign	Data range
Single-turn data	Not necessary	17 bit	Unsigned	0–131071
Multi-turn data	Backed up by battery	16 bit	Signed	-32768–32767

The servo driver set up actual position based on the following formulas at power up.

Since Single-turn data is 17-bit width and Multi-turn data is 16-bit width, the width of the synthetic data will be 33-bit width. However, the servo driver will return the lower 32 bits to the host controller as actual position.

Parameter Pr.0.00 (Rotational direction setup)	Actual_position *1)
When set to 1 (CCW is positive direction)	$APOS = M \times 2^{17} + S$
When set to 0 (CW is positive direction)	$APOS = -(M \times 2^{17} + S)$

APOS: Actual\_Position

M: Multi-turn\_Data

S: Single-turn\_Data

\*1) Expression when electronic gear ratio is 1:1

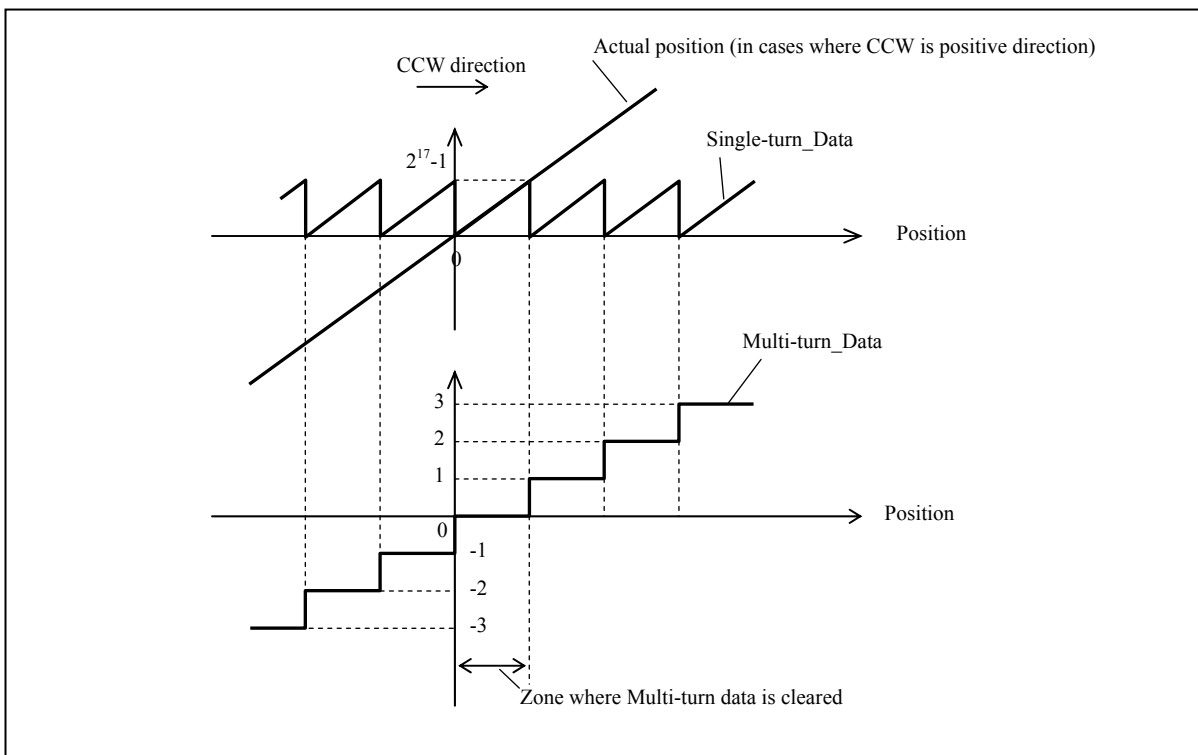

### 7-2-4-2 Clearing multi-turn data

When clearing multi-turn data, zero position will be multi-turn transition point at CW side in the zone where cleared. In order to avoid the setting difference, execute the clearing operation at the position where single-turn data is  $2^{16}$ , which is the farthest from the transition point of multi-turn data.

< Notes to avoid a trouble >

Execute this process (clear multi-turn data) in Servo-OFF (and fixing the moving parts by brake etc. if necessary) and confirming safety.

Keep Servo-OFF until data clearing completes. After that, turn off control power once without fail, and turn on the power again.

It is done to clear multi-turn data using the setup support software “PANATERM” (USB communication). At that time, Err. 27.1, “Motion command error” will occur. However, this is not a problem because of a step for safety.

As another way, the following figure shows the clearing sequence using homing command.

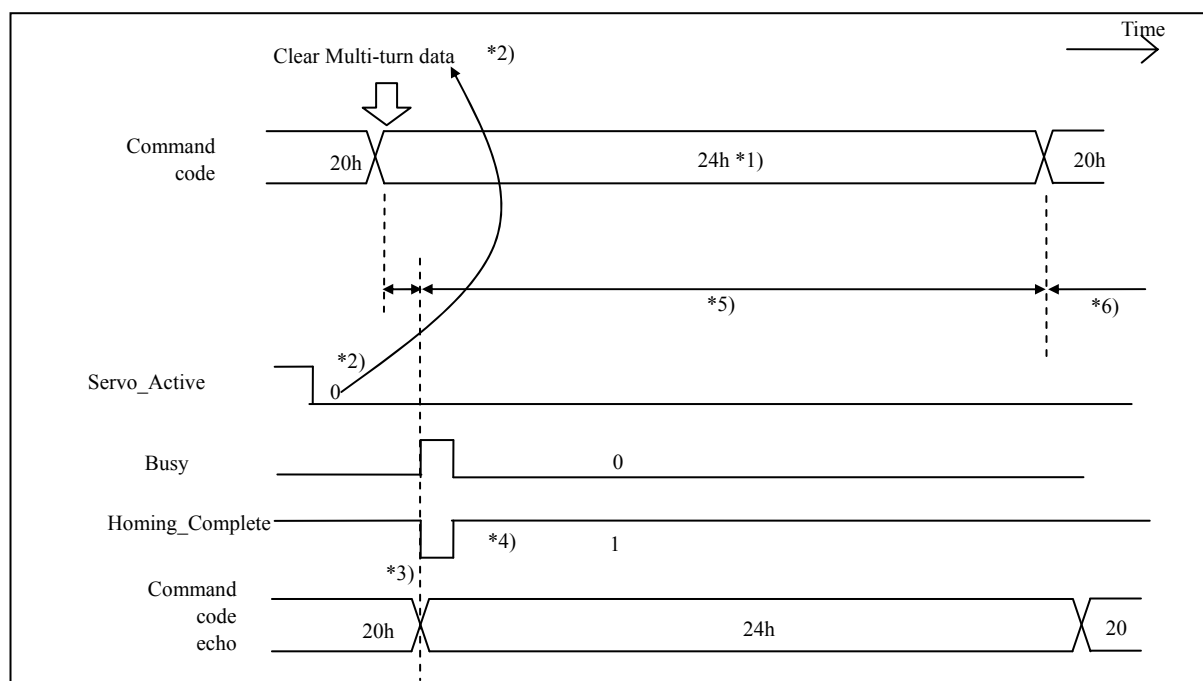

- \*1) If command code (24h) is not held, homing process (clear multi-turn data) will be aborted. While the process is executed, hold command code and do not abort homing process.
- \*2) Execute this process (clear multi-turn data) in Servo-OFF (and fixing the moving parts by brake etc. if necessary) and confirming safety to avoid a trouble.
- \*3) When using as the absolute mode, homing complete bit is 1 after the reset, and it will be 0 when this command is accepted.  
Multi-turn data in the servo driver will be cleared and actual position will be initialized.
- \*4) After initialization of the actual position Homing\_Complete bit is set to 1.
- \*5) After Command is accepted, hold Command Code (24h) for 10 ms or longer without fail. Though internal data of the servo driver will be initialized soon, actually it takes longer time to initialize the encoder.
- \*6) It is required to turn off and on the control power of the servo driver after clearing multi-turn data. Note that reset command cannot initialize the encoder



### 7-3 Cyclic velocity control (CV) operation

Use this operation when performing velocity control by setting command velocity to CSPD.

Servo driver's control mode is velocity control without position loop. Input the velocity command directly to the velocity loop.

When this command is received in the full-closed mode, Err91.1 (RTEX command error protection), command error (002Eh) will occur.

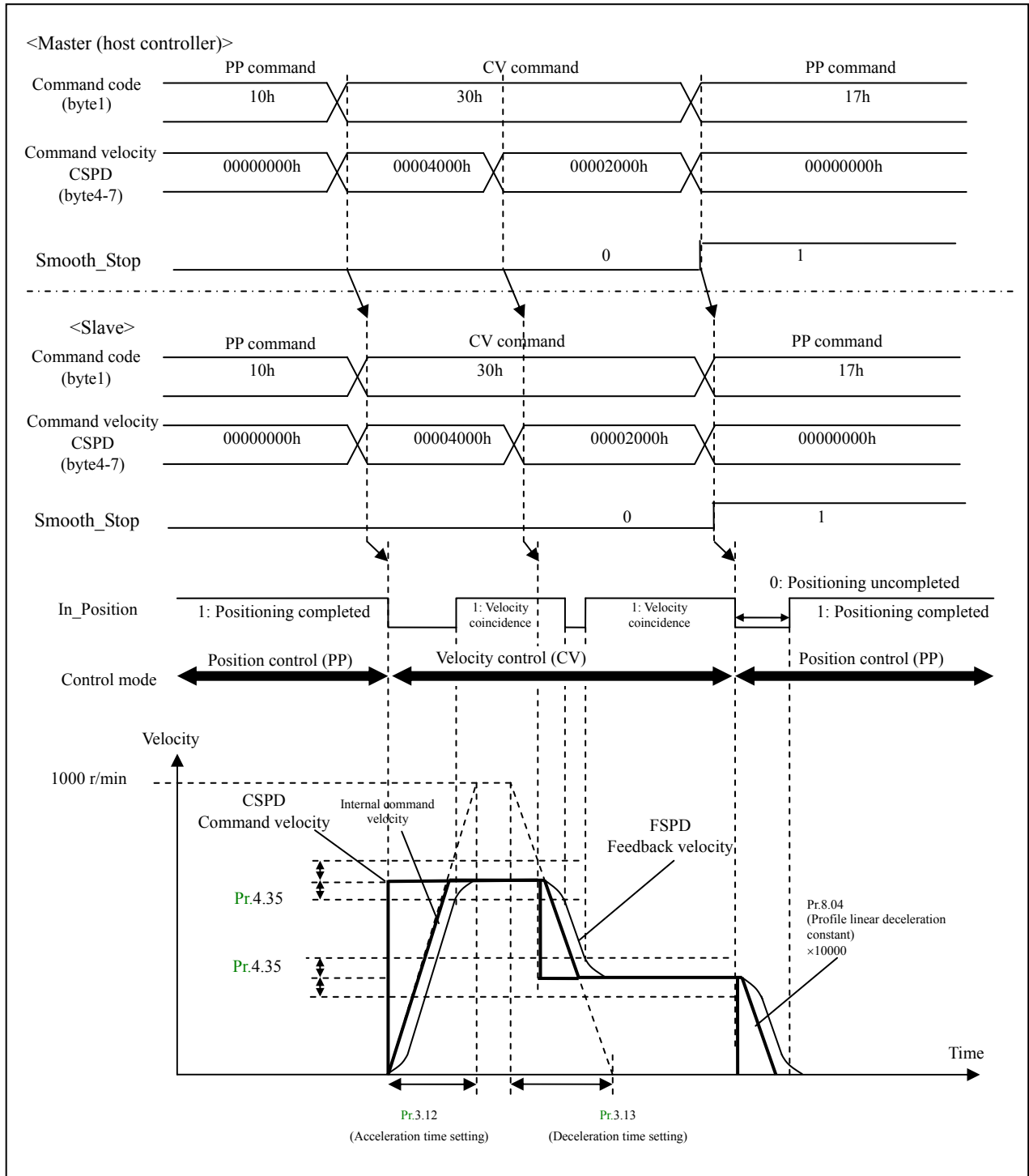

- 1) When using acceleration/deceleration for velocity command on the servo driver, set acceleration/deceleration through Pr.3.12 (Acceleration time setting), Pr.3.13 (Deceleration time setting) and Pr.3.14 (S-curve acceleration/deceleration) beforehand.

When the position loop is configured on the host controller, set Pr.3.12, Pr.3.13 and Pr.3.14 to 0.

When stop the operation with profile position control, set deceleration to Pr.8.04 (Profile linear deceleration constant) before starting operation.

- 2) On the host controller set command code to CV control normal command (30h) and set command velocity (CSPD).
- 3) On the servo driver, change control mode from position control to velocity control as the command code 10h changes to 30h, to accelerate (start operation) to command velocity (CSPD).
- 4) On the host controller, check that command code echo is 30h, no command error has occurred, and velocity control has started. If command error has occurred, start proper counter measure according to the error code.
- 5) When command velocity (CSPD) is changed during operation, the servo driver updates the velocity upon receiving the command.

If the new command velocity (CSPD) is higher than the current command velocity, acceleration is made based on Pr.3.12, and if the new command velocity is lower than the current velocity, deceleration is made based on Pr.3.13.

- 6) To start stopping sequence, set the command velocity (CSPD) to 0. To use profile position control during stop sequence, set command code to 17h and Hard\_Stop to 1 for immediate stop, or set Smooth\_Stop or Pause to 1 to start deceleration according to Pr.8.04 setting.
- 7) When profile position control is used for stopping sequence: after completion of output of movement command, status In\_Progress becomes 0 (transfer complete), and absolute value of position deviation becomes below Pr.4.31 (Positioning complete range), servo driver sets In\_Position to 1 and informs the host controller that positioning has been completed.

7-4 Cyclic torque control (CT) operation [Under review]

Use this operation when setting command torque to CTRQ and performing torque control operation. The servo driver operates in torque control mode based on velocity loop.

When this command is received in the full-closed mode, Err91.1 (RTEX command error protection), command error (002Eh) will occur.

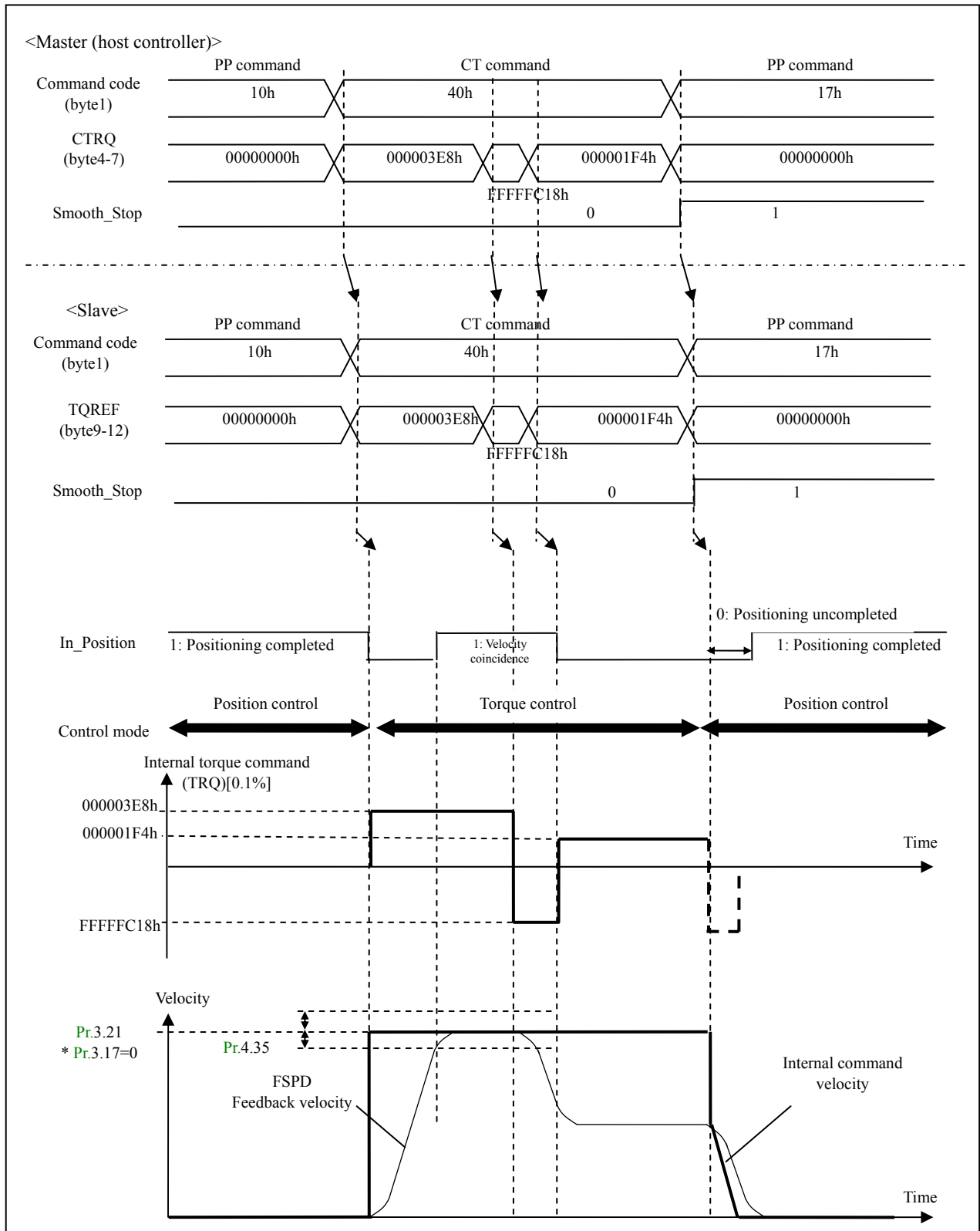

- 1) When stopping by using profile position control, set the deceleration by Pr.8.04 Profile linear deceleration constant beforehand.
- 2) The host controller sets command code to normal command (40h) of CT control and sets command torque (CTRQ).
- 3) The servo driver changes the control mode from position to torque as the command code is changed from 10h to 40h, starting acceleration (starting operation) according to command torque (CTRQ).
- 4) On the host controller check that command echo is 40h and no command error has occurred and torque control has started. If a command error has occurred, take appropriate countermeasure according to the error code.
- 5) Upon receiving new command torque (TRQ) during operation, servo driver updates the torque.
- 6) To trigger stop sequence, set command velocity (CSPD) to 0. To stop with profile position control, set command code to 17; to stop immediately, set Hard\_Stop to 1; to decelerate according to the setting of Pr.8.04, set Smooth\_Stop or Pause to 1.
- 7) When stopping under profile position control, the servo driver sets In\_Position to 1 as status In\_Progress is set to 0 (transfer complete) and absolute position deviation is below the value specified by Pr.4.31 (Positioning complete range), and informs the host controller that the positioning operation has completed.

■ Precautions

- While the velocity limit is active, the command torque (CTRQ) from the host controller is not directly applied to the motor. As the motor velocity is controlled to the velocity limit value, the result is reflected on the torque command to the motor. For velocity control function, refer to 4-2-3-4.
- While the torque control is active, torque limit switching function is disabled and only Pr.0.13 (1st torque limit) is valid.
- When absolute value of command torque (CTRQ) exceeds the value of Pr.0.13 (1st torque limit), Pr.0.13 is given priority.

## 7-5 Profile position control (PP) operation

## 7-5-1 Profile position control (PP) related parameter

Class	No.	Attribute	Title	Setup range	Unit	Description
8	01	B	Profile linear acceleration constant	1-65535	10000 command unit/s <sup>2</sup>	Set acceleration for profile position control (PP). Be sure to set this parameter before starting operation.
8	04	B	Profile linear deceleration constant	1-65535	10000 command unit/s <sup>2</sup>	Set deceleration for profile position control (PP). Be sure to set this parameter before starting operation.
8	10	B	Movement distance after detection of profile position latch	-1073741823 - 1073741823	Command unit	Set the movement distance after detection of latch trigger signal input position, during profile position latch positioning.
8	12	B	Profile homing mode setting	0-1	-	Select the polarity of latch trigger signal to be detected during profile homing operation. 0: Positive direction 1: Negative direction • For profile homing 2, select 0 setting. Setting to 1 also causes homing operation in positive direction.
8	13	B	Profile homing velocity 1	0- 2147483647	Command unit/s or r/min	Set the velocity for high velocity operation during profile homing.  Set the unit according to Pr.7.25 RTEX velocity unit setup. Maximum value is limited by the internal process to the motor highest velocity. • When speed setting is in r/min, it is converted to command unit/s through internal computation and the equivalent value is limited within the range as shown below: -80000001h to 7FFFFFFh (-2147483647 to 2147483647)  When setting value is 0, it is changed to 1 by internal process and used for control.
8	14	B	Profile homing velocity 2	0- 2147483647	Command unit/s or r/min	Set the velocity for low velocity operation during profile homing. To minimize detection error, set the velocity to the lowest possible value. Set the unit according to Pr.7.25 RTEX velocity unit setup. Maximum value is limited by the internal process to the motor highest velocity. • When speed setting is in r/min, it is converted to command unit/s through internal computation and the equivalent value is limited within the range as shown below: -80000001h to 7FFFFFFh (-2147483647 to 2147483647)  When setting value is 0, it is changed to 1 by internal process and used for control.

7-5-2 Profile absolute positioning (Type\_Code: 10h)

Set target position (absolute position) to TPOS. Servo driver performs positioning by internally generates position command.

Before executing, establish the home (return to home).

In the incremental mode, positioning can be done without determining the home, but be sure to read the servo driver internal position information beforehand to prevent movement to unintentional position.

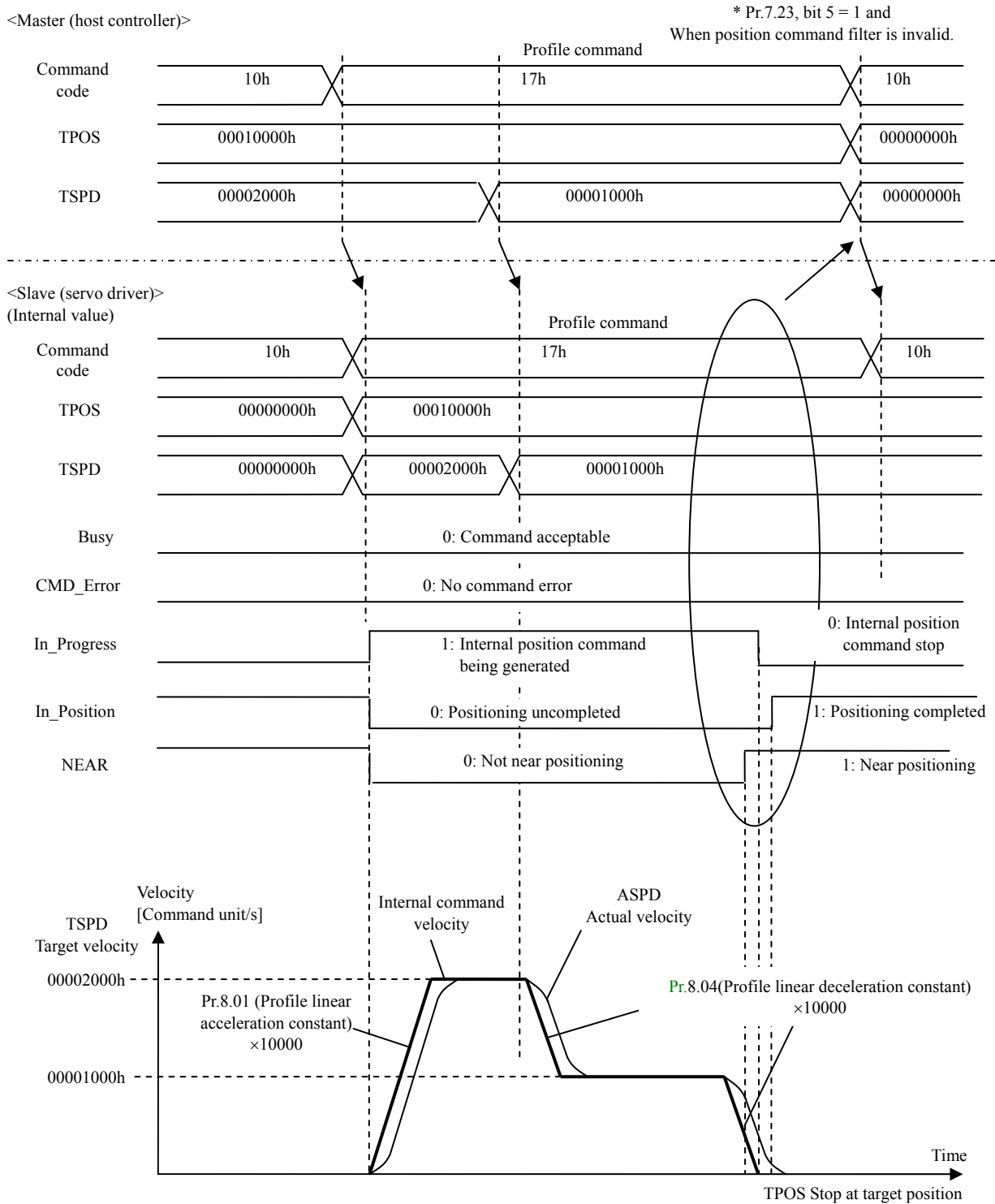

- 1) On the master (host controller), set command code to normal command (10h) of PP control. This does not directly trigger profile operation.  
Before operating, set acceleration/deceleration through Pr.8.01 Profile linear acceleration constant/Pr.8.04 Profile linear deceleration constant.
- 2) With command code 10h, set Type\_Code to 10h, target position (TPOS) and target speed (TSPD). Set the target position as absolute position.  
Select data to be returned to Monitor\_Data in Latch\_Sel1 0 and Monitor\_Sel.  
This does not directly trigger profile operation.
- 3) Change command code from 10h to 17h.
- 4) The servo driver starts the profile operation as the command code is changed from 10h to 17h, starting acceleration (starting operation) to the target velocity (TSPD).
- 5) On the host controller check that command echo is 17h, Type\_Code echo is 10h and status In\_Progress is 1, and no command error has occurred and absolute positioning has started. If command error has occurred, take proper counter measure according to the error code.
- 6) When changing the target position (TPOS)/target speed (TSPD) during operation, follow the procedure shown below.

- Pr.7.23, bit 5 = 0: start as reference command changes  
With command code 10h, change the target position (TPOS)/target speed (TSPD) value, and return to step 3).
- Pr.7.23, bit 5 = 1: start as command code and command argument change  
With command code 17h, change the target position (TPOS)/target speed (TSPD) value.

If the new target position (TPOS) is near than the current internal command position (before filtering: IPOS), decelerate and stop according to Pr.8.04 and then accelerate to the new target position (TPOS).

If the new target speed (TSPD) is larger than the current command speed, accelerate according to Pr.8.01, and if TSPD is smaller than the current command speed, decelerate according to Pr.8.04.

- 7) Then decelerate toward the target position (TPOS) at the rate set by Pr.8.04.
- 8) When the distance from internal command position (IPOS) to the target position becomes shorter than Pr.8.16 Profile positioning neighborhood range, NEAR becomes 1 (profile positioning neighborhood). After outputting movement to target position command, the servo driver sets status In\_Progress to 0 (transfer complete). As the absolute value of position deviation decreases below Pr.4.31 Positioning complete range, the driver sets In\_Position to 1 and informs the host controller that the positioning has completed.

#### ■ Precautions

- Other non-cyclic commands except for certain homing commands may be executed during operation (In\_Progress = 1) while maintaining profile operation. However, do not change the operation mode (Type\_Code, Latch\_Sel1 of profile command), otherwise, Err91.1 (RTEX command error protection) and command error (0104h) will occur.
- If target speed (TSPD) is set at 0 or if Pause is set at 1, In\_Progress will not be set to 0 (Internal position command stop) after deceleration and stop. To end the process during operation, transmit Hard\_Stop or Smooth\_Stop, then, In\_Progress will be set to 0 (transfer complete) at stop.

### 7-5-3 Profile relative positioning (Type\_Code: 11h)

Specify relative movement distance to TPOS and the servo driver performs positioning by internally generating position command. To prevent movement to unintentional position, read servo driver internal command position (before filtering: IPOS) while internal command generation is paused (In\_Progress = 0) in PP control mode, before starting operation.

Note: Internal command position (IPOS) changes by following motor position during servo off, velocity control (CV) and torque control (CT).

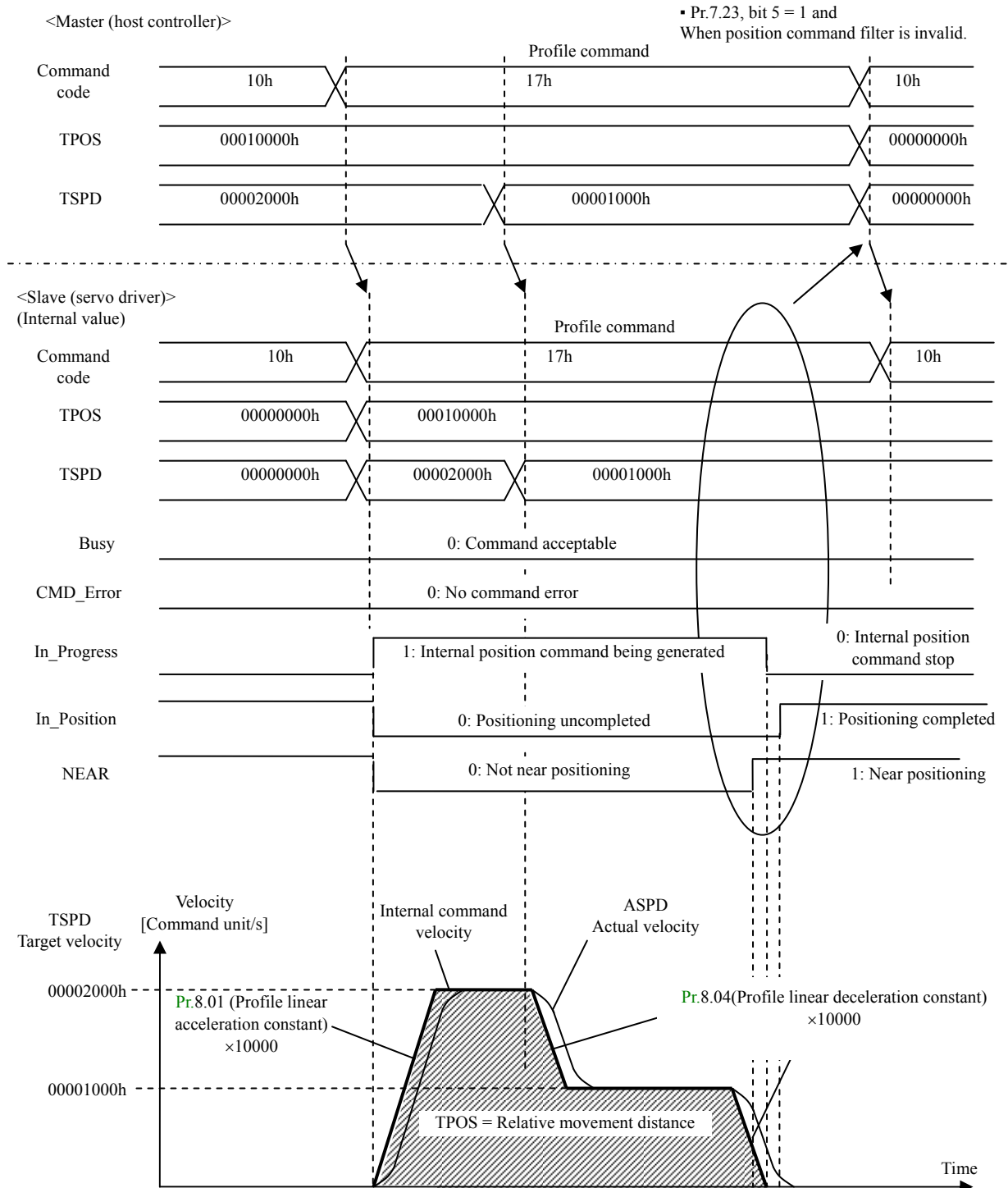



- 1) On the host controller, set command code to normal command (10h) of PP control.  
This setting does not directly trigger profile operation.  
Before operating, set acceleration/deceleration according to Pr.8.01 Profile linear acceleration constant and Pr.8.04 Profile linear deceleration constant.
- 2) With command code 10h, set Type\_Code to 11h, relative movement distance (TPOS) and target speed (TSPD). Set Latch\_Sel1 to 0, and for Monitor\_Sel, select data to be returned to Monitor\_Data.  
This does not directly trigger profile operation.
- 3) Change command code from 10h to 17h.
- 4) As command code changes from 10h to 17h, the servo driver sets the internal target position to the value shown below, starts profile operation and accelerates (starts operation) to the target speed (TSPD).

Internal target position = internal command position (before filtering: IPOS) + relative movement distance (TPOS)

- 5) The host controller checks that command echo is 17h, Type\_Code echo is 11h and status In\_Progress is 1, and no command error has occurred and relative positioning has started. If command error has occurred, take proper countermeasure according to the error code.
- 6) When changing the target speed (TSPD), follow the procedure shown below.

- Pr.7.23, bit 5 = 0: start as reference command changes  
With command code 10h, change the target speed (TSPD) value, and return to step 3).
- Pr.7.23, bit 5 = 1: start as command code and command argument change  
With command code 17h, change the target speed (TSPD) value.

If the new target speed (TSPD) is higher than the current command speed, accelerate the current speed according to setting in Pr.8.01 and, if new TSPD is lower than the current command speed, decelerate the current speed according to Pr.8.04.

- 7) Then decelerate toward the internal target position at a rate set by Pr.8.04.
  - 8) When the distance from internal command position (IPOS) to the target position becomes shorter than Pr.8.16 Profile positioning neighborhood range, NEAR becomes 1 (profile positioning neighborhood). After outputting the movement to internal target position command, the servo driver sets status In\_Progress to 0 (transfer complete). As the absolute value of position deviation decreases below Pr.4.31 Positioning complete range, the driver sets In\_Position to 1 and informs the host controller that the positioning has completed.
- Precautions
- Other non-cyclic commands except for homing command may be executed during operation (In\_Progress = 1) while maintaining profile operation. However, do not change the operation mode (Type\_Code, Latch\_Sel1 of profile command), otherwise, Err91.1 (RTEX command error protection) and command error (0104h) will occur.
  - Do not change relative movement distance (TPOS) during operation. For relative movement, internal target position is calculated with reference to the internal command position (IPOS) at the time the currently operating command is started (in Step 4) above.
  - When target speed (TSPD) is set at 0 or Pause is set at 1, In\_Progress will not be set to 0 (Internal position command stop) at the stop after deceleration. To end the process during operation, transmit Hard\_Stop or Smooth\_Stop, then, In\_Progress will be set to 0 (transfer complete) at stop.

7-5-4 Profile position latch absolute positioning (Type\_Code: 12h)

Specify the target position (absolute position) to TPOS and the servo driver performs positioning by internally generating position command. During positioning, it updates the target position upon detecting latch signal.

Perform the positioning after establishing home (after completion of return-to-home).

To prevent movement to unintentional position, read position information from the servo driver although the positioning can be started before determining the home in the incremental mode.

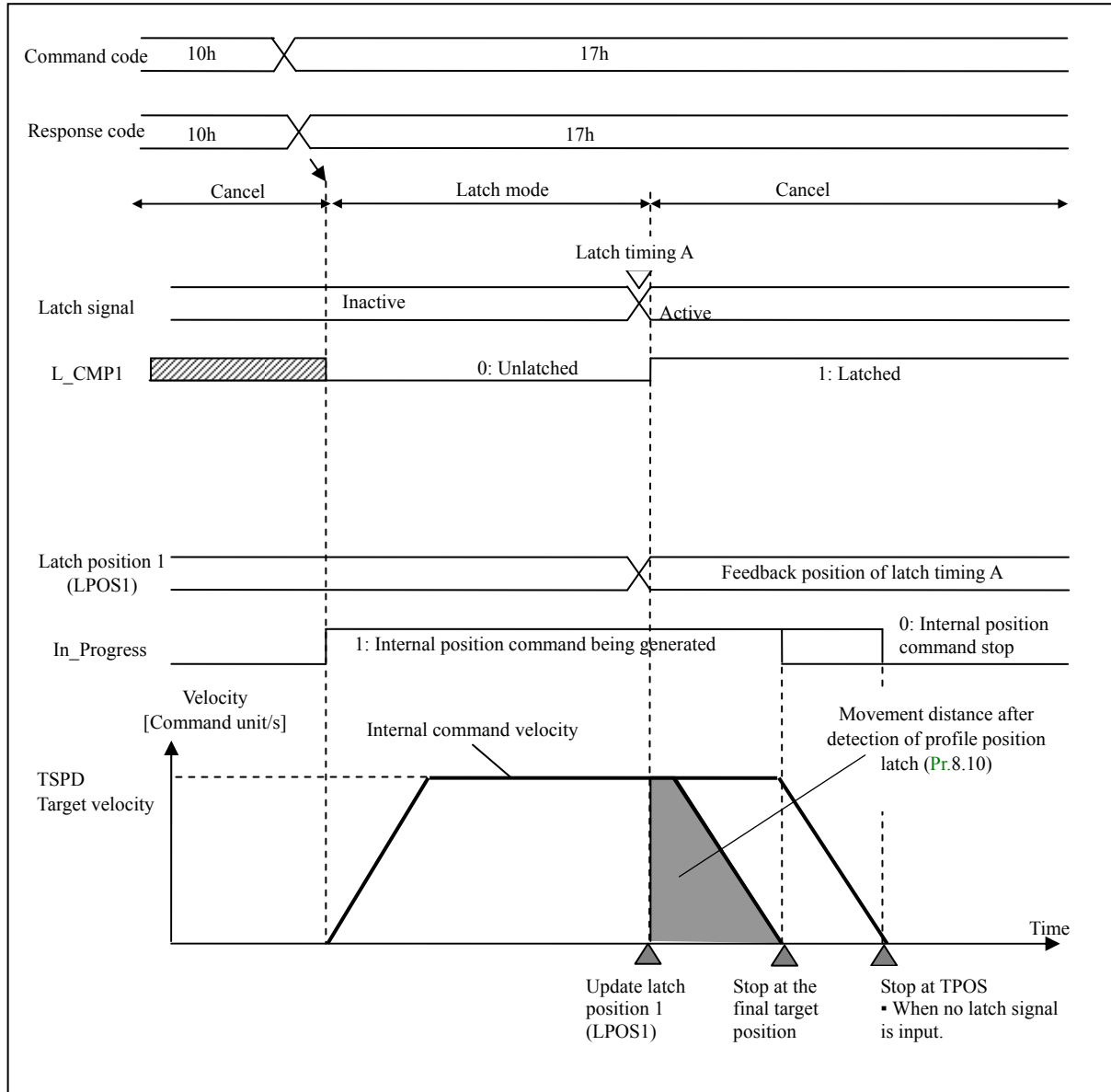

- 1) On the host controller, set command code to normal command (10h) of PP control.  
This setting does not directly trigger profile operation.  
Before starting operation, set acceleration/deceleration according to Pr.8.01 Profile linear acceleration constant and Pr.8.04 Profile linear deceleration constant; set distance of movement after detection of latch signal according to Pr.8.10 Movement distance after detection of profile position latch.
- 2) With command code 10h, set Type\_Code to 12h, target position (absolute position) (TPOS) and target speed (TSPD).  
Select latch trigger signal as Latch\_Sel1 and for Monitor\_Sel select data to be returned to Monitor\_Data.  
This does not directly trigger profile operation.
- 3) Change command code from 10h to 17h.
- 4) As command code changes from 10h to 17h, the servo driver starts profile operation and accelerates (starts operation) to the target speed (TSPD).
- 5) The host controller checks that command echo is 17h, Type\_Code echo is 12h and status In\_Progress is 1, and no command error has occurred and absolute positioning has started. If command error has occurred, take proper counter measure according to the error code.
- 6) Upon detecting latch trigger signal, update the internal target position as follows:
 

$\text{Internal target position} = \text{Latch position 1 (LPOS1)} + \text{movement distance after detection of profile position latch (Pr.8.10)}$
--
- 7) Then decelerate toward the internal target position at the rate set according to setting of Pr.8.04.
- 8) When the distance from internal command position (IPOS) to the target position becomes shorter than Pr.8.16 Profile positioning neighborhood range, NEAR becomes 1 (profile positioning neighborhood). After outputting movement to target position command, the servo driver sets status In\_Progress to 0 (transfer complete). As the absolute value of position deviation decreases below Pr.4.31 Positioning complete range, the driver sets In\_Position to 1 and informs the host controller that the positioning has completed.

■ Precautions

- Other non-cyclic commands except for homing command may be executed during operation (In\_Progress = 1) while maintaining profile operation. However, do not change the operation mode (Type\_Code, Latch\_Sel1 of profile command), otherwise, Err91.1 (RTEX command error protection) and command error (0104h) will occur.
- When target speed (TSPD) is set at 0 or Pause is set at 1, In\_Progress will not be set to 0 (Internal position command stop) at the stop after deceleration. To end the process during operation, transmit Hard\_Stop or Smooth\_Stop, and In\_Progress will be set to 0 (transfer complete) at stop.
- The operation after detection of latch signal input position is as shown below depending on the positioning direction and the sign of parameter Pr.8.10 Movement distance after detection of profile position latch.

		Sign of Pr.8.10	
		Positive number	Negative number
Position latch Positioning direction	Positive direction	Stop after moving in positive direction (See Note)	Stop after deceleration and reverse direction and move in negative direction and then stop
	Negative direction	Stop after deceleration and reverse direction and move in positive direction and then stop	Stop after moving in negative direction (See Note)

Note: When the movement distance after detection of profile position latch is short for deceleration distance, reverse will occur after deceleration and stop.

- The latch position 1 (LPOS1) and position latch complete 1 (L\_CMP1) will be maintained until the subsequent latch process starts or latch mode is canceled. However, upon initialization of position information or resetting of control power source or if communication is not established, latch position 1 (LPOS1) is undefined: repeat the latch process.
- When repeating position latching, transmit normal command 10h after position latching and then start the subsequent latching process.
- When external latch input signal is used, latch position 1 (LPOS1) is not correctly read. To minimize the error rate, lower the speed around latch signal input as low as possible.
- Be sure to maintain the value of the latch signal (Latch\_Sel1) while processing this command (latch detection process).
- If the target position is reached without detection of latch signal, latch status will be held.

#### 7-5-5 Profile position latch relative positioning (Type\_Code: 13h)

Specify the relative movement distance to TPOS and the servo driver performs positioning by internally generating position command. During positioning, it updates the target position upon detecting latch signal.

To prevent movement to unintentional position, read command position (before filtering: IPOS) from the servo driver while pausing internal command generation (In\_Progress = 0) in the PP control mode.

Note: The internal command position (IPOS) will vary with the motor position during servo off, velocity control (CV) and torque control (CT).

This positioning differs from the profile position latch absolute positioning in Type\_Code at starting and in specifying method of target position (TPOS).

For details of operation of the profile position latch absolute positioning, refer to 7-5-4.

7-5-6 Profile continuous revolution (JOG) (Type\_Code: 20h)

In this mode, target position (TPOS) is not specified but target speed (TSPD) is specified; and positioning starts as the servo driver internally generates position command and continues revolution (JOG) until stop command is given.

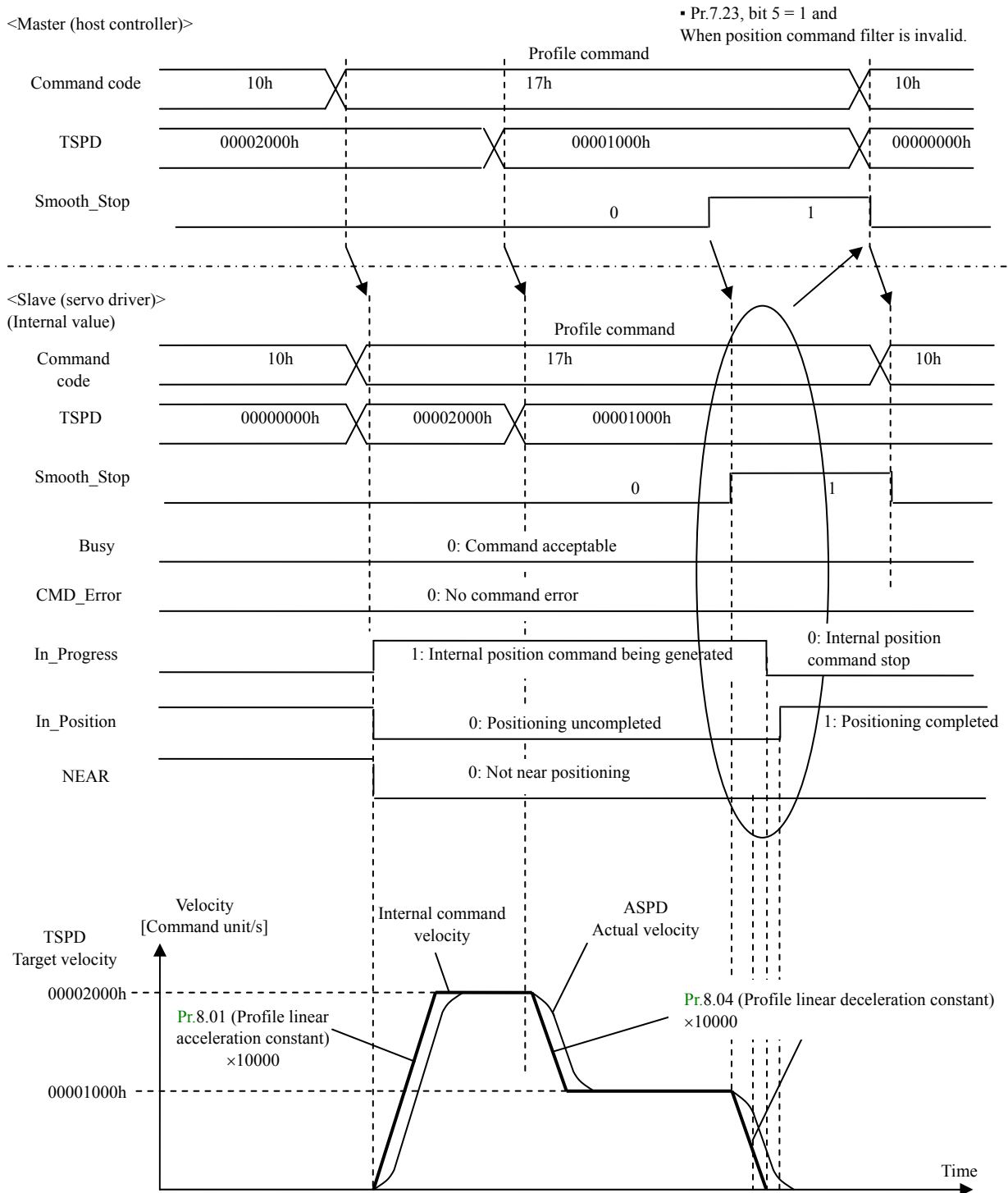

- 1) On the master (host controller), set command code to normal command (10h) of PP control. This does not directly trigger profile operation.  
Before operating, set acceleration/deceleration through Pr.8.01 Profile linear acceleration constant/Pr.8.04 Profile linear deceleration constant.
- 2) With command code 10h, set Type\_Code to 20h and target speed (TSPD).  
Set the target position (TPOS) to 0 because it is not used.  
Set 0 to Latch\_Sel1, select data to be returned to Monitor\_Data in Monitor\_Sel.  
This does not directly trigger profile operation.
- 3) Change command code from 10h to 17h.
- 4) The servo driver starts the profile operation as the command code is changed from 10h to 17h, starting acceleration (starting operation) to the target velocity (TSPD).
- 5) The host controller checks that command echo is 17h, Type\_Code echo is 20h and status In\_Progress is 1, and no command error has occurred and absolute positioning has started. If command error has occurred, take proper counter measure according to the error code.
- 6) When changing the target speed (TSPD), follow the procedure shown below.

- Pr.7.23, bit 5 = 0: start as reference command changes  
With command code 10h, change the value of target speed (TSPD), and return to step 3).
- Pr.7.23, bit 5 = 1: start as command code and command argument change  
With command code 17h, change the value of target speed (TSPD).

If the new target speed (TSPD) is larger than the current command speed, accelerate it according to Pr.8.01, or if new TSPD is smaller, decelerate it according to Pr.8.04.

- 7) To stop immediately, set Hard\_Stop to 1; to decelerate according to setting of Pr.8.04, set Smooth\_Stop or Pause to 1.
  - 8) While operating in profile continuous revolution (JOG) mode, NEAR remains 0 because no target position is set. After outputting the movement command, the servo driver sets In\_Progress to 0 (transfer complete), and as the absolute value of position deviation decreases below Pr.4.31 Positioning complete range, the driver sets In\_Position to 1 and informs the host controller that the positioning has completed.
- Precautions
- Other non-cyclic commands (e.g. monitor command) may be executed during operation (In\_Progress = 1) while maintaining profile operation. However, do not change the operation mode (Type\_Code, Latch\_Sel1 of profile command), otherwise, Err91.1 (RTEX command error protection) and command error (0104h) will occur.
  - If target speed (TSPD) is set at 0 or if Pause is set at 1, In\_Progress will not be set to 0 (Internal position command stop) after deceleration and stop. To end the process during operation, transmit Hard\_Stop or Smooth\_Stop, then, In\_Progress will be set to 0 (transfer complete) at stop.

7-5-7 Profile homing 1 (HOME + Z phase) (Type\_Code: 31h)

This return-to-home process uses Z phase from HOME sensor as the trigger signal.

In this system, the position of the first Z phase after the HOME sensor in homing direction detected the rising edge is denoted as the home position.

As the unit stops at the home position, the position information is initialized so that the position is set to 0.

Direction of homing (positive/negative) can be set according to Pr.8.12 Profile homing mode setting.

■ Example: Pr.8.12 = 0 (Homing direction = positive direction trigger signal detection)

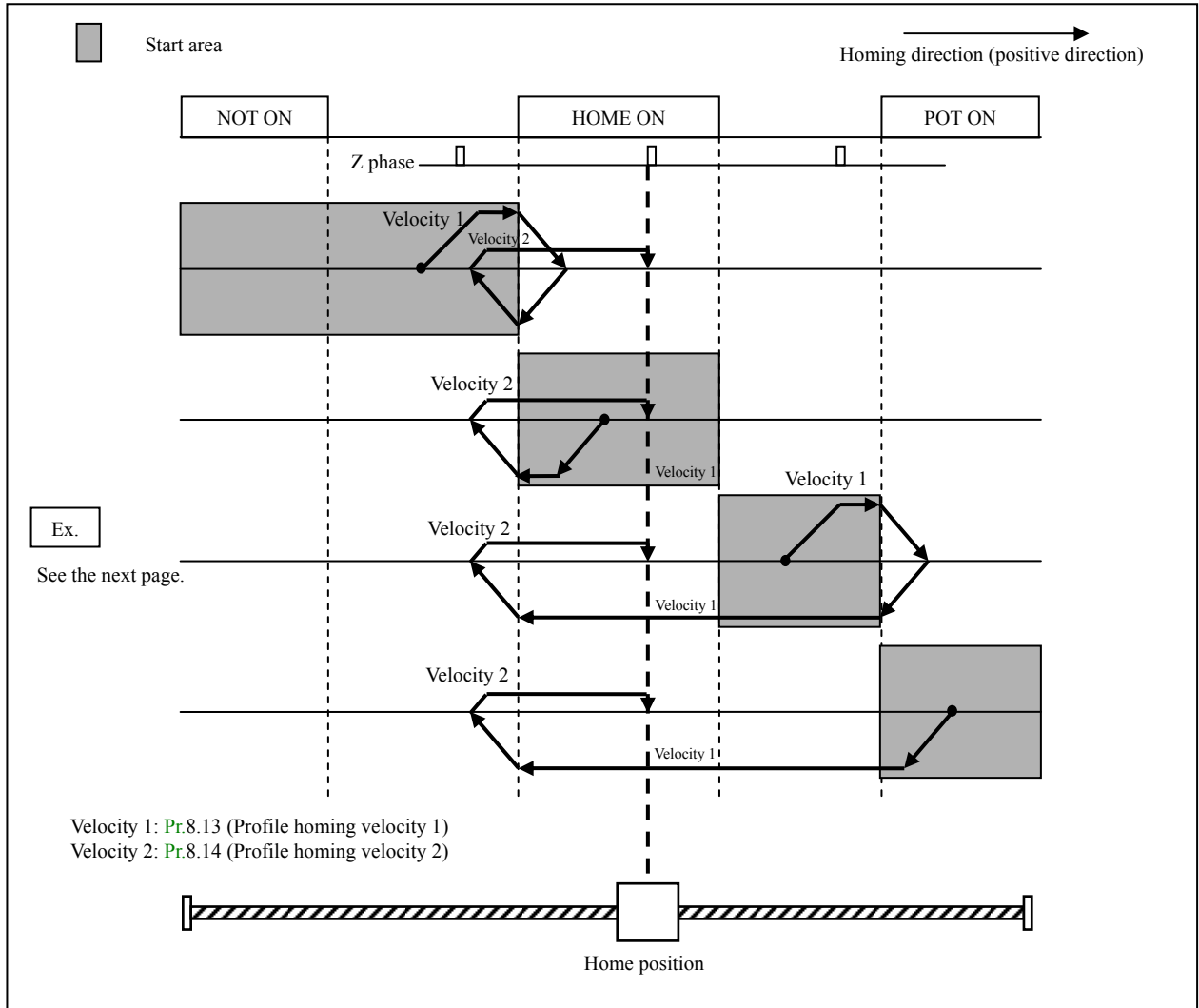



Example: Pr.8.12 = 0 (Positive direction trigger signal detection)—homing is started at a position more positive than HOME sensor

- 1) The host controller sets the command code to normal command (10h) of PP control.  
This does not start the profile operation.  
Parameters related to acceleration/deceleration (Pr.8.01/Pr.8.04) and homing (Pr.8.12–Pr.8.14) should be set before starting operation.
- 2) With normal command (10h) condition, set Type\_Code to 31h.  
Set target position (TPOS) and target speed (TSPD) to 0 because they are not used.  
Set Latch\_Sel1 to 0. For Monitor\_Sel, select data to be returned to Monitor\_Data.  
This does not directly start profile operation.
- 3) Change command code 10h to 17h.
- 4) The servo driver starts profile operation as command code 10h changes to 17h, accelerates operation (starts operation) according to Pr.8.11 Profile linear acceleration constant to reach Pr.8.13 Profile homing velocity 1. Note that upon starting the profile operation, Homing\_Complete is set to 0.
- 5) The host controller checks that command code echo is 17h, Type\_Code echo is 31h and status In\_Progress is 1, and no command error has been generated, and homing operation has started. If command error is detected, the controller should take appropriate countermeasure according to the error code.
- 6) When POT is detected before HOME sensor detection, start deceleration according to Pr.8.04 to stop.
- 7) At the stop position, start movement in the direction opposite to the homing at the speed specified by Pr.8.13.
- 8) When HOME sensor turns on and then OFF edge is detected, start deceleration at the rate specified by Pr.8.04.
- 9) At the stop position, start movement in the homing direction, accelerating according to Pr.8.14 Profile homing velocity 2, re-entering HOME sensor area and stop upon detecting the 1st Z phase.
  - Actually, detected position is determined by repositioning.
- 10) Initialize the position information so that the detected Z phase becomes 0 and Homing\_Complete becomes 1, and profile homing is finished.

#### ■ Precautions

- If Z phase is close to a point where HOME changes, the 1st Z phase may not be detected as home due to reading delay of HOME sensor. Place Z phase far away from the point where HOME sensor changes the output.
- Sensors (HOME, POT, NOT) should be so arranged that once they detect something, nothing will pass through them until deceleration and stop complete.
- During profile homing 1 (HOME + Z phase), Pr.5.04 Over-travel inhibit input setup and Pr.5.05 Sequence at over-travel inhibit are temporarily disabled. When POT/NOT is detected, reverse operation will automatically start after deceleration and stop.  
When using this function without using the over-travel inhibit input, do not allocate POT/NOT to general purpose input. Simply setting Pr.5.04 to 1 will not disable the function.
- If an error occurs during homing, e.g. the sensor cannot detect the home during reverse operation due to the over-travel inhibit input and detects the over-travel inhibit input ON of reverse side, or, if both of over-travel inhibit inputs are ON state, Err94.2 (Homing error protection) will occur, canceling homing process.
- Other non-cyclic commands except for homing commands may be executed during operation (until Homing\_Ccomplete becomes 1) while maintaining profile operation. However, do not change the operation mode (Type\_Code, Latch\_Sel1 of profile command), otherwise, Err91.1 (RTEX command error protection) and command error (0104h) will occur.

7-5-8 Profile homing 2 (HOME + Z phase) (Type\_Code: 32h)

This return-to-home process uses Z phase from HOME sensor as the trigger signal.

Home position is defined as the point where HOME sensor detects the rising edge in return-to-home direction. After stopping at the home position, initialize the position information so that this position is set at 0.

Only positive homing direction is supported.

Set Pr.8.12 Profile homing mode setup to 0.

Setting Pr.8.12 to 1 also causes homing in positive direction.

■ Example: Pr.8.12 = 0 (Homing direction = positive direction trigger signal detection)

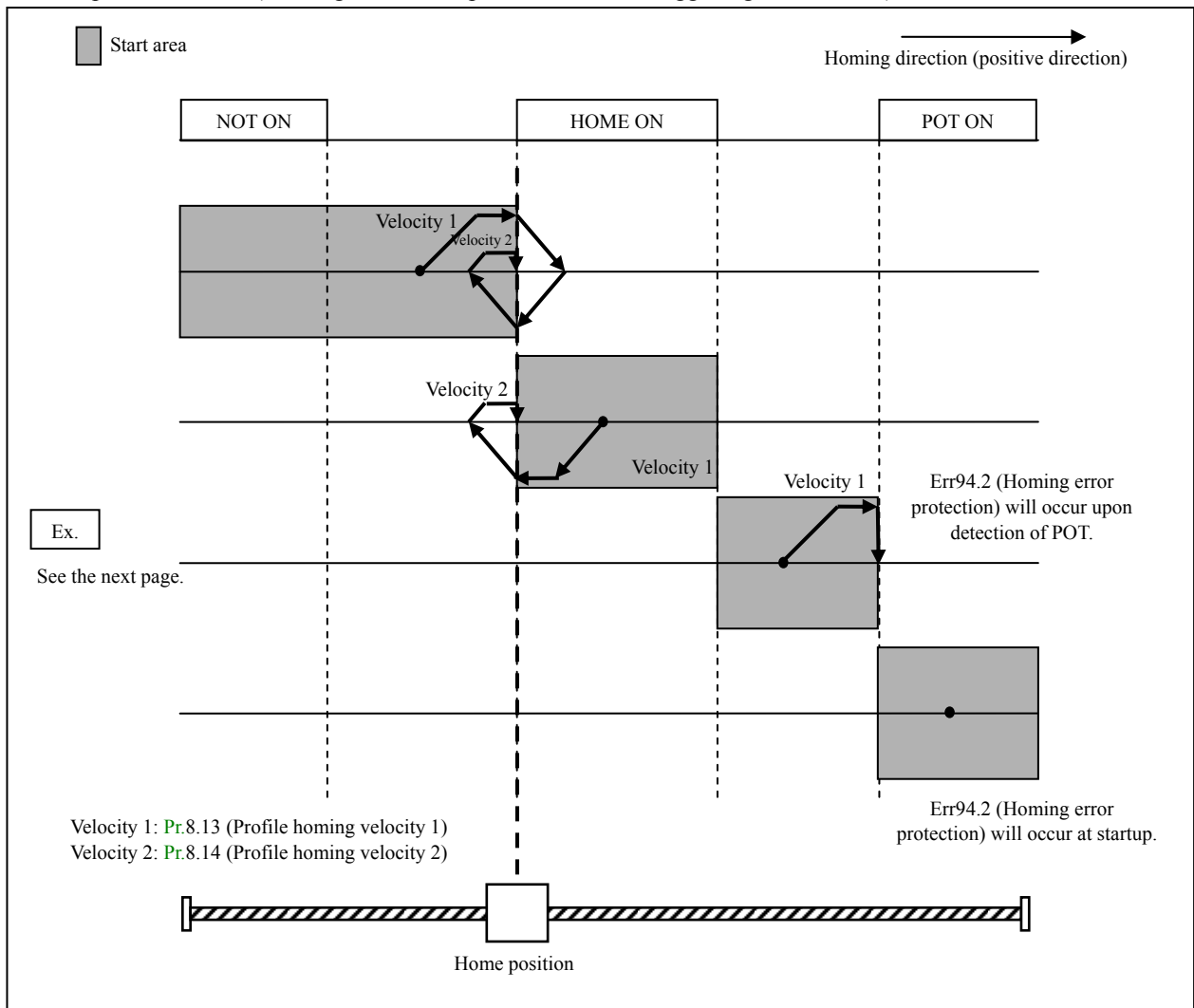

Example: Pr.8.12 = 0 (Positive direction trigger signal detection)—homing is started at a position more positive than HOME sensor

- 1) The host controller sets the command code to normal command (10h) of PP control.  
This does not start the profile operation.  
Parameters related to acceleration/deceleration (Pr.8.01/Pr.8.04) and homing (Pr.8.12–Pr.8.14) should be set before starting operation.
- 2) With normal command (10h) condition, set Type\_Code to 32h.  
Set target position (TPOS) and target speed (TSPD) to 0 because they are not used.  
Set Latch\_Sel1 to 0. For Monitor\_Sel, select data to be returned to Monitor\_Data.  
This does not directly start profile operation.
- 3) Change command code 10h to 17h.
- 4) The servo driver starts profile operation as command code 10h changes to 17h, accelerates operation (starts operation) according to Pr.8.11 Profile linear acceleration constant to reach Pr.8.13 Profile homing velocity 1. Note that upon starting the profile operation, Homing\_Complete is set to 0.
- 5) The host controller checks that command code echo is 17h, Type\_Code echo is 32h and status In\_Progress is 1, and no command error has been generated, and homing operation has started. If command error is detected, the controller should take appropriate countermeasure according to the error code.
- 6) When HOME sensor turns on, start deceleration according to Pr.8.04 to stop.
- 7) At the stop position, start movement in the direction opposite to the homing at the speed specified by Pr.8.13.
- 8) When HOME sensor turns on and then OFF edge is detected, start deceleration at the rate specified by Pr.8.04.
- 9) At the stop position, start movement in the homing direction, accelerating according to Pr.8.14 Profile homing velocity 2, and stop at the position where HOME sensor ON (rising edge) is detected.
  - Actually, detected position is determined by repositioning.
- 10) Initialize the position information so that the detected HOME sensor rising edge is at 0 and Homing\_Complete becomes 1, and profile homing is finished.

#### ■ Precautions

- Set Pr.8.14 Profile homing velocity 2 to the lowest possible velocity. Higher velocity may cause error due to delay in reading.
- HOME sensors should be so arranged that once they detect something, nothing will pass through them until deceleration and stop complete.
- During profile homing 2 (HOME + Z phase), when the detected POT/NOT and the direction of homing are the same direction, Err94.2 (Homing error protection) will occur and cancel homing process. When using this function without using the over-travel inhibit input, do not allocate POT/NOT to general purpose input. Simply setting Pr.5.04 to 1 will not disable the function.
- Other non-cyclic commands except for homing commands may be executed during operation (until Homing\_Ccomplete becomes 1) while maintaining profile operation. However, do not change the operation mode (Type\_Code, Latch\_Sel1 of profile command), otherwise, Err91.1 (RTEX command error protection) and command error (0104h) will occur.

7-5-9 Profile homing 3 (Z phase) [Type\_Code: 33h]

This homing sequence uses Z phase as the trigger signal.

Define the 1st Z phase position in the homing direction as the home position.  
 Stop at the home and initialize the position information to set this position at 0.

Direction of homing can be set to either positive or negative through the setting of Pr.8.12 Profile homing mode setup.

■ Example: Pr.8.12 = 0 (Homing direction = positive direction trigger signal detection)

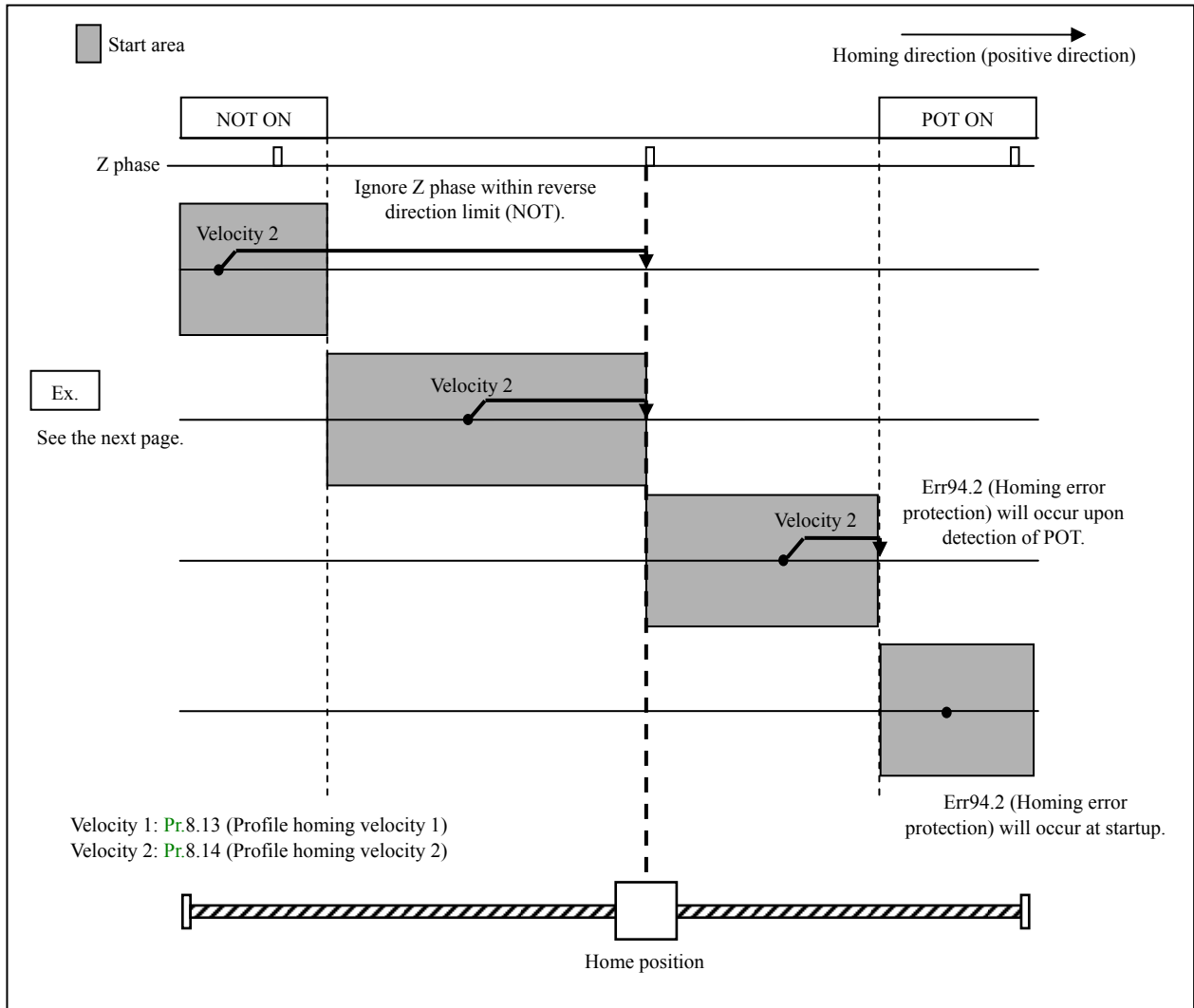

Example: Pr.8.12 = 0 (Positive direction trigger signal detection)—homing is started at a position more positive than HOME sensor

- 1) The host controller sets the command code to normal command (10h) of PP control.  
This does not start the profile operation.  
Parameters related to acceleration/deceleration (Pr.8.01/Pr.8.04) and homing (Pr.8.12–Pr.8.14) should be set before starting operation.
- 2) With normal command (10h) condition, set Type\_Code to 33h.  
Set target position (TPOS) and target speed (TSPD) to 0 because they are not used.  
Set Latch\_Sel1 to 0. For Monitor\_Sel, select data to be returned to Monitor\_Data.  
This does not directly start profile operation.
- 3) Change command code 10h to 17h.
- 4) The servo driver starts profile operation as command code 10h changes to 17h, accelerates operation (starts operation) according to Pr.8.11 Profile linear acceleration constant to reach Pr.8.14 Profile homing velocity 2. Note that upon starting the profile operation, Homing\_Complete is set to 0.
- 5) The host controller checks that command code echo is 17h, Type\_Code echo is 33h and status In\_Progress is 1, and no command error has been generated, and homing operation has started. If command error is detected, the controller should take appropriate countermeasure according to the error code.
- 6) Stop at the position where the 1st Z phase is detected.
  - Actually, detected position is determined by repositioning.
- 7) Initialize the position information to set the detected Z phase position to 0, and set Homing\_Complete to 1 to finish profile homing sequence.

■ Precautions

- When the detected direction of drive inhibit input and the direction of homing are the same, Err94.2 (Homing error protection) will occur, disabling reversal of movement direction.
- When the detected direction of drive inhibit input is opposite to the homing direction, Z phase is not detected or ignored.
- During profile homing 3 (Z phase), when the detected POT/NOT and the direction of homing are the same direction, Err94.2 (Homing error protection) will occur and cancel homing process.  
When using this function without using the over-travel inhibit input, do not allocate POT/NOT to general purpose input. Simply setting Pr.5.04 to 1 will not disable the function.
- Other non-cyclic commands except for homing commands may be executed during operation (until Homing\_Ccomplete becomes 1) while maintaining profile operation. However, do not change the operation mode (Type\_Code, Latch\_Sel1 of profile command), otherwise, Err91.1 (RTEX command error protection) and command error (0104h) will occur.

## 7-5-10. Precautions for profile position control operation

- When relative displacement exceeds 7FFFFFFFh (command unit), wraparound process is used.

<Example of wraparound process: As TPOS changes from 7FFFFFFFh to 80000000h>

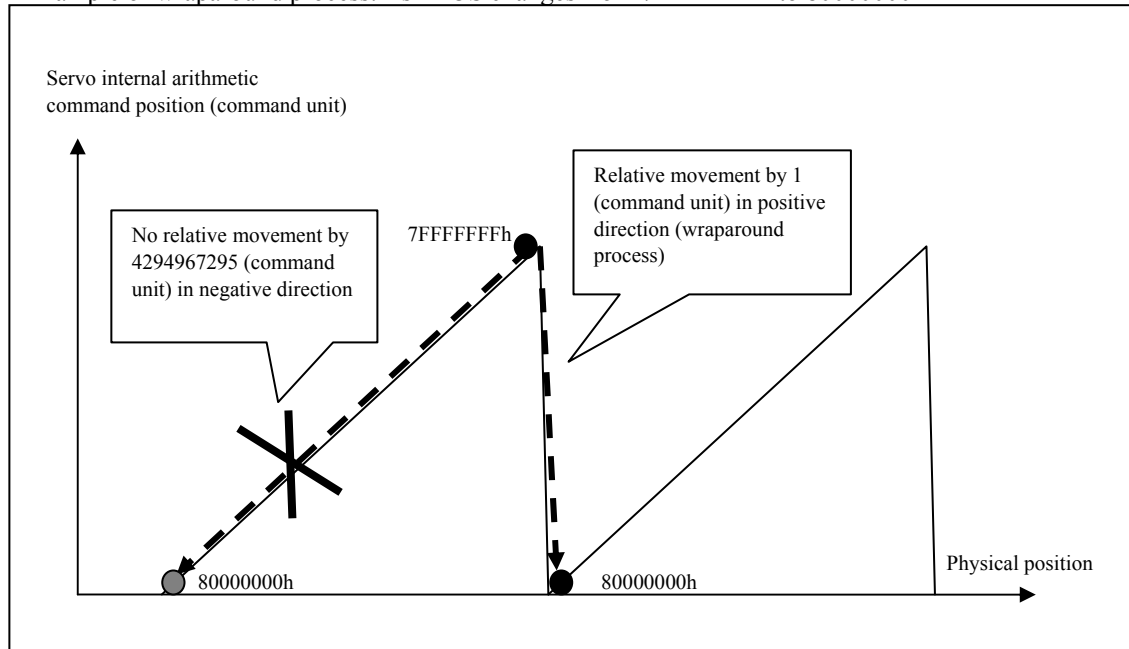

- When the latch trigger signal is applied from external source, it should be detected at the lowest possible speed. If it is detected at a higher speed, with very low electronic gear ratio (e.g. 1/1000), wraparound of detection position will occur upon reverse conversion to command unit (latch position is not exactly detected).
- When the target speed (TSPD) is set outside the range, it causes command error (0032h).  
Maximum target speed will be the motor maximum speed or 7FFFFFFFh (command unit/s), whichever small.  
Note: Motor maximum speed includes errors caused by rounding in calculating process and by electronic gear.
- During acceleration, deceleration will be started if continuous acceleration may cause movement beyond the target position. As a result, the speed may not reach the target speed (TSPD).
- When deceleration is made to the target speed which is slower than the current internal command speed, and even if the resulting speed difference is smaller than the difference between decelerations, deceleration is made according to the new deceleration rate and then acceleration will be made to attain the target speed. If this process causes a problem, take corrective measures, e.g. decrease Pr.8.04 (profile linear deceleration constant).

- The speed (including initial speed upon changing control mode) at the start of deceleration and Pr.8.04 (profile linear deceleration constant) shall meet the following restriction.

<Restriction>

Amount of movement distance (P) necessary to decelerate from the initial speed to the target speed < 7FFFFFFh (command unit)

For example, if the initial speed upon switching from the cyclic torque control does not meet the restriction, Err.27.5 (command generation error protection) will be generated.

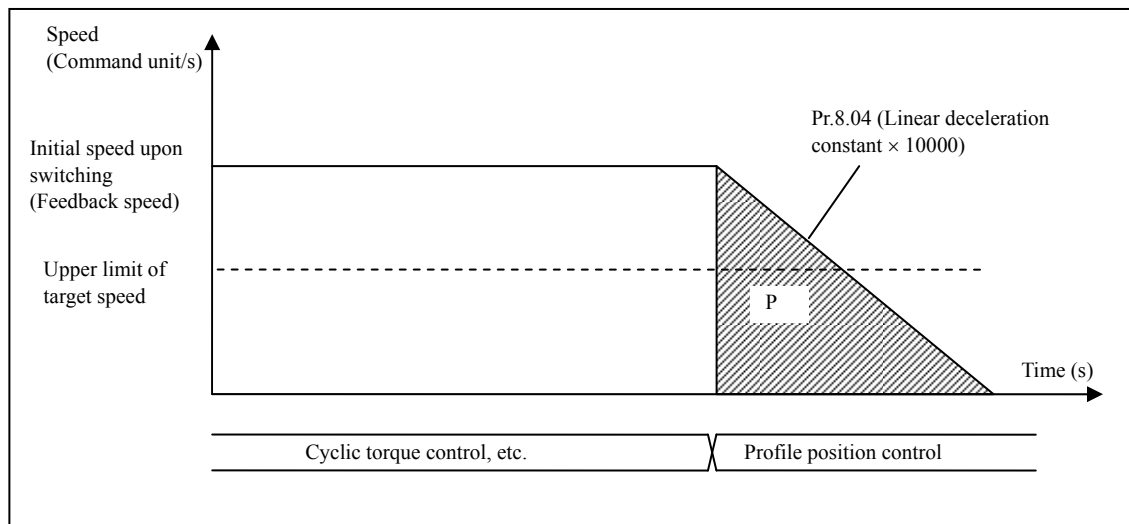

## 7-6 Control mode switching

### 7-6-1 Control mode switching method

- When cyclic command change is received, the control mode is changed accordingly. MINAS-A5N can response to the new control mode changed during operation. For precautions for mode change during operation, refer to 7-6-2 and for other precautions refer to 7-6-3.
- The non-cyclic command just prior to command mode change must be “Normal command (□0h)”, and be sure to change the control mode while “Non-cyclic command” is not being executed (Busy = 0). If the control mode is changed while non-cyclic command is being executed (Busy = 1), Err91.1 (RTEX command error protection) and command error (002Eh) will occur.

Example: During operation in CV (cyclic velocity control), mode is changed to PP (profile positioning)

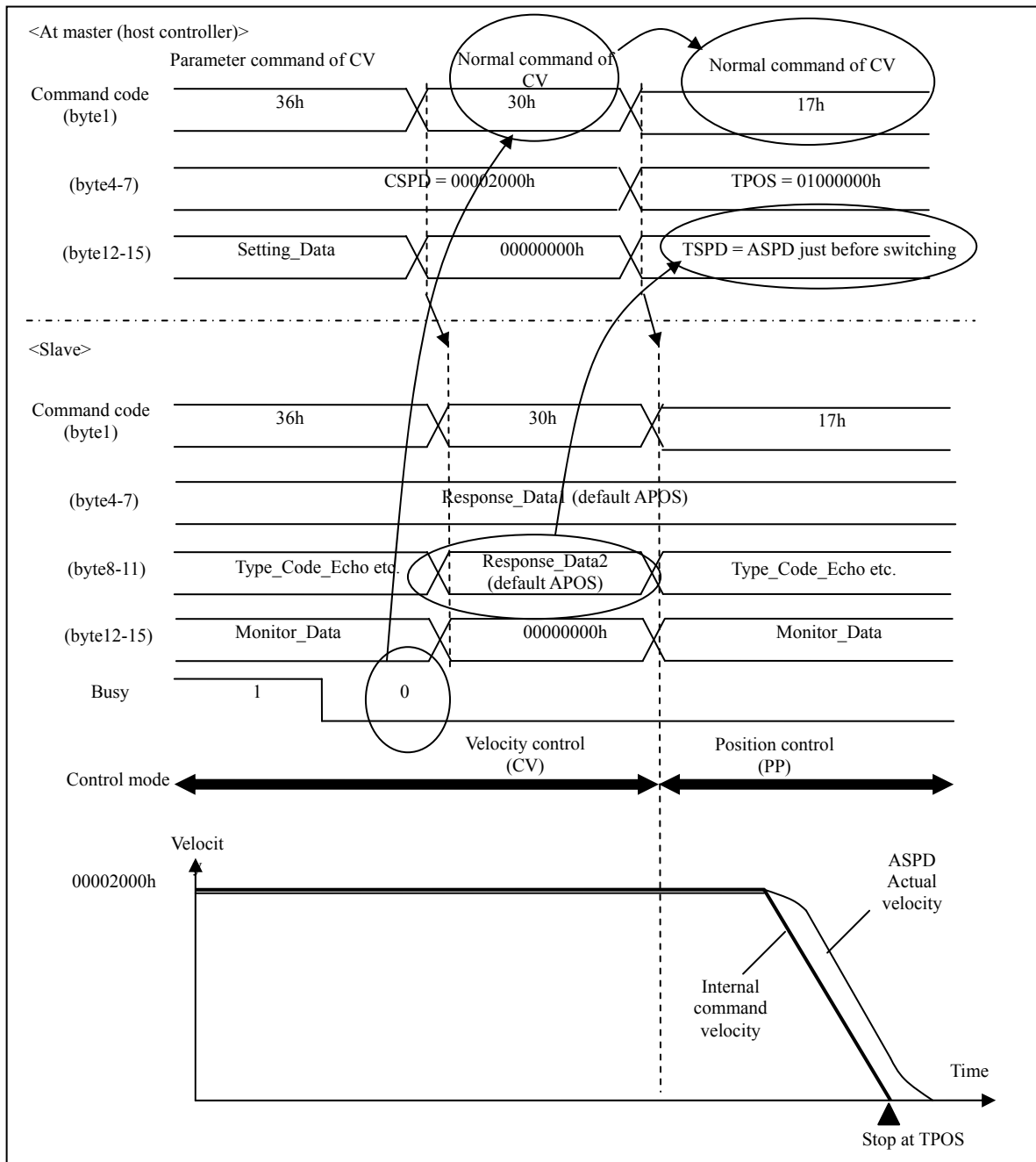



## 7-6-2 Precautions for control mode change during operation

- Switching between modes PP (profile position control), CV (cyclic velocity control) and CT (cyclic torque control) during operation is possible.
- Upon switching to PP during operation, the profile operation should be started: change to 17h and not to 10h.
- Switching from CP (cyclic position control) to PP, CV or CT is possible during operation. In contrast, switching to CP is possible while operation is paused.  
To smoothly change control mode to CP, when applying the command from the host controller, command position (TPOS) should include correction process.  
When changing from PP to CP, control mode remains position control, but correction is required to command position (TPOS) of given command.

## Supported switching during operation

After switching Before switching	PP (17h)	CP (2□h)	CV (3□h)	CT (4□h)
PP(10h)		×	○	○
CP(20h)	○		○	○
CV(30h)	○	×		○
CT(40h)	○	×	○	

- Do not change control mode during the following PP operation.  
Otherwise, Err91.1 (RTEX command error protection) and command error (002Eh) will occur.

Type_Code	Operation mode
12h	Profile position latch absolute positioning
13h	Profile position latch relative positioning
31h	Profile homing 1
32h	Profile homing 2
33h	Profile homing 3

- When changing control mode during operation, correctly apply the command so that the velocity in the previous and new modes are the same.

Actual velocity (APOS) before mode change = command velocity (target velocity) after mode change
--

When control mode is changed during acceleration/deceleration, mode may not be smoothly changed. Even at the constant velocity, mode may not be smoothly changed due to certain factor, e.g. if acceleration/deceleration setting is large.

- Before changing mode from CV or CT to PP with position command filter (FIR, smoothing) enabled, a steady constant velocity should have been maintained for a period longer than the filter time constant (FIR, smoothing total setting time).
- For smooth switching between control modes, disable the damping filter because the damping filter is active only for position control.
- When the gain changes after switching of control mode, switching is not smoothly performed.

<u>There are some other conditions</u> that prevent smooth switching operation.
---

If the vibration during switching cause problem, perform switching while related sections are in stop condition.
--

### 7-6-3 Other precautions related to control mode switching

- After servo-off (including alarm state), counter clear or deceleration and stop according to drive inhibit input, the control mode in the servo driver is forced to change to PP and internal position command generation process is forced to stop.

For example, if the main power is turned off in CV status, servo is turned off and internal status is switched to PP. Result: status and monitor data that rely on control mode will be switched to position control instead of velocity control.

- When command is NOP (0□h), or if cyclic command is not correctly received due to command error or communication error, the previous command mode will be maintained. Note that commands (command velocity etc.) to servo driver will not be disabled. For NOP command, refer to 7-1-2, for command error, refer to 6-10, and for communication error, refer to 6-11.
- When communication cycle is 0.0833 ms or 0.1666 ms, generation of response data (e.g. position deviation) depending on control mode will delay. For details, refer to 3-1-3 and 3-1-4.
- During full-closed control, only position control is enabled and switching to CV or CT is disabled. Upon receiving CV or CT during full-closed control, Err91.1 (RTEX command error protection) and command error (002Eh) will occur.
- For communication cycle/command update cycle, 16-byte mode/32-byte mode and combination of compatible control modes, refer to 2-5-1. If unsupported combination is selected, it will cause Err91.1 (RTEX command error protection) and command error (002Eh).
- When selecting another control mode (cyclic command), wait for at least 2 ms. When several control modes are repeatedly switched within 2 ms, Err91.1 (RTEX command error protection) and command error (002Eh) will occur.
- When homing command (□4h) except for latch mode is being executed, do not change control mode. Before changing control mode, be sure to perform homing process and select the normal command (□0h). Follow the basic switching method described above.

## 7-7 Feedforward function

The host controller can transmit high resolution velocity feedforward (VFF) and torque feedforward (TFF).

## 7-7-1 Feedforward function validation parameter and command area to be used

■ Main command: Common to 16-byte and 32-byte modes

Byte	bit7	bit6	bit5	bit4	bit3	bit2	bit1	bit0
0	C/R	Update_Counter		MAC-ID				
1	TMG CNT	Command Code						
2-3	Control_Bits							
4-7	Command_Data1							
8-11	Command_Data2							
12-15	Command_Data3							

Class	No.	Attribute	Parameter title	Setup range	Unit	Description
7	35	C	RTEX command setup 1	0-2	-	Set up non-cyclic command Command_Data3. 0: Disable 1: Velocity feedforward (Command unit/s) or r/min 2: Torque feedforward (0.1%)

Note: For non-cyclic command that uses Command\_Data3 area as Setting\_Data, disable is selected because feedforward data cannot be transmitted (see table below), previously received value is used for operation. If this operation causes problem, use Sub\_Command\_Data2/3 in 32-byte mode area shown on the next page. When Pr.7.35 = 0 (Disable feedforward), use Command\_Data3 area as Setting\_Data, and set value to 0 when non-cyclic command is not used (see the table below). When setup is not 0, Command error (0032h) will be returned.

Non-cyclic command	Type_Code	FF transmission Enable/disable	Command_Data3				
			Pr7.35 = 0	Pr7.35 = 1	Pr7.35 = 2		
Normal	0h	All	-	○	FF Disable (set it as 0)	Velocity FF	Torque FF
Reset	1h	All	-	○	FF Disable (set it as 0)	Velocity FF	Torque FF
System ID	2h	All	-	○	FF Disable (set it as 0)	Velocity FF	Torque FF
Homing	4h	021h/022h	Actual position/command position set	×	Setting_Data (setting position)	Setting_Data (setting position)	Setting_Data (setting position)
		Others	-	○	FF Disable (set it as 0)	Velocity FF	Torque FF
Alarm	5h	All	-	○	FF Disable (set it as 0)	Velocity FF	Torque FF
Parameter	6h	011h	Parameter writing	×	Setting_Data (parameter value)	Setting_Data (parameter value)	Setting_Data (parameter value)
		Others	-	○	FF Disable (set it as 0)	Velocity FF	Torque FF
Profile	7h	All	-	×	Setting_Data (target velocity)	Setting_Data (target velocity)	Setting_Data (target velocity)
Monitor	Ah	All	-	○	FF Disable (set it as 0)	Velocity FF	Torque FF

■ Subcommand: Only for 32-byte mode

Byte	bit7	bit6	bit5	bit4	bit3	bit2	bit1	bit0
16	Sub_Chk	0	0	0	Sub_Command_Code			
17	Sub_Type_Code							
18-19	Sub_Index							
20-23	Sub_Command_Data1							
24-27	Sub_Command_Data2							
28-31	Sub_Command_Data3							

Class	No.	Attribute	parameter Title	Setup range	Unit	Description
7	36	C	RTEX command setup 2	0-2	-	Set subcommand, Sub_Command_Data2. 0: Disable 1: Velocity feedforward (Command unit/s) or (r/min) 2: Torque feedforward (0.1%)
7	37	C	RTEX command setup 3	0-2	-	Set subcommand, Sub_Command_Data3. 0: Disable 1: Velocity feedforward (Command unit/s) or (r/min) 2: Torque feedforward (0.1%)

## 7-7-2 Setting unit and setting range

	Description						
Velocity feedforward (VFF)	<p>After converting the unit, add the value to velocity feedforward value calculated by Pr.1.10 and Pr.1.11, within the range up to motor maximum speed.</p> <p>[Size]: Signed 32-bit</p> <p>[Unit]: Set according to Pr.7.25 RTEX velocity unit setup.</p> <table border="1"> <thead> <tr> <th>Pr.7.25</th> <th>Unit</th> </tr> </thead> <tbody> <tr> <td>0</td> <td>[r/min]</td> </tr> <tr> <td>1</td> <td>[command unit/s]</td> </tr> </tbody> </table> <p>[Setting range] : - motor max. velocity to + motor max. velocity</p>	Pr.7.25	Unit	0	[r/min]	1	[command unit/s]
Pr.7.25	Unit						
0	[r/min]						
1	[command unit/s]						
Torque feedforward (TFF)	<p>After converting the unit, add the value to torque feedforward value calculated according to Pr.1.12 and Pr.1.13, within the range up to motor maximum torque.</p> <p>[Size]: Signed 32-bit</p> <p>[Unit] : 0.1%</p> <p>[Setting range]: - motor max. torque to + motor max. torque</p>						

## 7-7-3 Compatible control mode

The feedforward functions are compatible with the following control modes.

For block diagrams of these control modes, refer to Technical Reference, SX-DSV02202"Section 5-2", Functional Specification.

	Position control (CP)	Position control (PP)	Velocity control (CV)	Torque control (CT)
Velocity feedforward (VFF)	Valid ○	Invalid ×	Invalid ×	Invalid ×
Torque feedforward (TFF)	Valid ○	Valid ○	Valid ○	Invalid ×

#### 7-7-4 Other precautions related to feedforward function

- If multiple feedforward functions are set in 32-byte mode, Err93.5 (Parameter setting error protection 4) will occur. This error will not occur in 16-byte mode.
- When invalidating feedforward through the parameter, set the command area to 0. Otherwise, command error (0034h) will occur.
- During servo-lock after completion of homing, feedforward remains valid. When this state causes problem, keep feedforward value at 0 during cyclic homing sequence.
- During deceleration and stop process with servo-off, counter clear or drive inhibit input (POT/NOT), feedforward is at 0.
- When feedforward value in drive inhibit direction is set after deceleration and stop process triggered by drive inhibit input (POT/NOT), command error (0046h) will occur and feedforward value is set to 0.
- When setting value is outside the range, command error (0034h) will occur and previous normal value is held.
- When the value set during switching of control mode is outside the range, command error (0034h) will also occur and the previous normal value will be maintained. If the feedforward in the control mode before switching is invalid, the value is 0.
- In control mode with invalid feedforward, the feedforward value is 0.

## 8. RTEX Communication Related Protective Function and Troubleshooting

## 8-1 RTEX communication related protective function

Alarm code (Decimal)		Designation	Attribute			[COM] display
Main	Sub		History memory	Can be cleared	Immediate stop	
82	0	RTEX node addressing error protection	○	-	-	Lights in red
83	0	RTEX continuous communication error protection 1	○	○	○	Blinks in red
	1	RTEX continuous communication error protection 2	○	○	○	Blinks in red
84	0	RTEX time out error protection	○	○	○	Blinks in red
	3	RTEX synchronization and initialization error protection	○	-	-	Lights in red
	5	RTEX communication cycle error protection	○	○	○	Blinks in red
86	0	RTEX cyclic data error protection 1	○	○	○	Blinks in red
	1	RTEX cyclic data error protection 2	○	○	○	Blinks in red
	2	RTEX UpdateCounter error protection	○	-	○	Lights in red
90	2	RTEX interaxis sync establishment error protection	○	-	-	Lights in red
91	1	RTEX command error protection	○	○	○	Blinks in red
98	1	RTEX hardware error protection 1	○	-	-	Lights in red
	2	RTEX hardware error protection 2	○	-	-	Lights in red
	3	RTEX hardware error protection 3	○	-	-	Lights in red

## 8-1-1 RTEX node address setting error protection (Err. 82.0)

This alarm will occur when the value set on the node address setting rotary switch on the servo driver is outside the setting range.

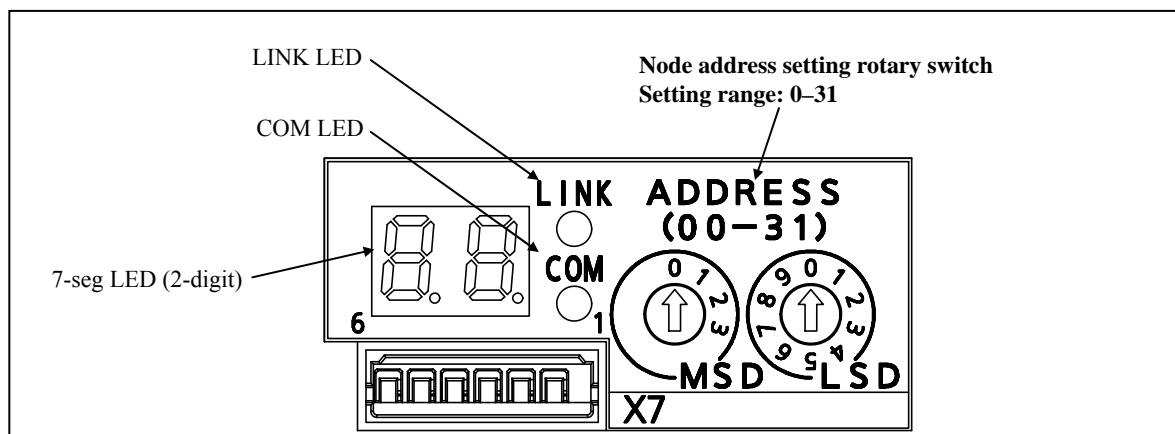

Cause	<ul style="list-style-type: none"> <li>The value set on the rotary switch is outside of 0 to 31.</li> </ul>
Detecting timing	<ul style="list-style-type: none"> <li>Upon power up of servo driver control power supply</li> <li>Upon restarting by the reset command</li> </ul>
Internal process upon detecting error	<ul style="list-style-type: none"> <li>RTEX communication is not established (aborted due to incomplete initialization)</li> <li>RTEX communication state is kept INITIAL (transition).</li> </ul>
Action	<ul style="list-style-type: none"> <li>Check the value set on the node address setting rotary switch.</li> <li>When necessary, correct the setting value (0-31), and turn on the servo driver control power.</li> <li>Replace the servo driver as necessary.</li> </ul>
Alarm clear attribute	<ul style="list-style-type: none"> <li>Cannot be cleared.</li> </ul>
Display on COM LED	<ul style="list-style-type: none"> <li>Lighting in red</li> </ul>



## 8-1-2 RTEX continuous communication error protection 1 (Err. 83.0)

This alarm will occur when reading error (CRC error) of the data delivered to the local node persists for the predetermined period.

Cause	<ul style="list-style-type: none"> <li>• Reading error (CRC error) of the data delivered to the local node persists for the predetermined period.</li> </ul>
Detecting timing	<ul style="list-style-type: none"> <li>• When RTEX communication status is RUNNING.</li> <li>• When received data is read at the communication cycle.</li> </ul>
Internal process upon detecting error	<ul style="list-style-type: none"> <li>• Discard the received data.</li> <li>• Use the previously received normal data for processing (servo is in alarm status).</li> <li>• Return Byte 1 of response as FFh.</li> <li>• RTEX communication keeps RUNNING status. <ul style="list-style-type: none"> <li>▪ Because the communication continues, if the normal reception is possible after occurrence of alarm, commands such as alarm clear can be received.</li> </ul> </li> </ul>
Action	<ul style="list-style-type: none"> <li>• Check the communication cable for excessive noises.</li> <li>• Check the communication cable for length, layout arrangement, and connections.</li> <li>• Check that the communication cable is category 5-e or better shielded twisted pair cable (STPC) specified by TIA/EIA-568.</li> <li>• Replace the cable with a new one as necessary.</li> <li>• Attach the ferrite core to the communication cable.</li> <li>• Replace the servo driver as necessary.</li> </ul>
Alarm clear attribute	<ul style="list-style-type: none"> <li>• Can be cleared.</li> </ul>
Display on COM LED	<ul style="list-style-type: none"> <li>• Flashing in red</li> </ul>

## 8-1-3 RTEX continuous communication error protection 2 (Err. 83.1)

This alarm will occur when reading error of the data delivered to the local node persists for the predetermined period. This alarm indicates that CRC error, missing reception or cyclic error of the data delivered to the local node has occurred.

If these errors occur alternatively, they are distinguished by the alarm.

Cause	<ul style="list-style-type: none"> <li>• Reading error (CRC error, missing reception or cyclic error) of the data delivered to the local node persists for the predetermined period.</li> </ul>
Detecting timing	<ul style="list-style-type: none"> <li>• When RTEX communication status is RUNNING.</li> <li>• When received data is read at the communication cycle. <ul style="list-style-type: none"> <li>▪ Missing reception will be detected only when sync is established.</li> </ul> </li> </ul>
Internal process upon detecting error	<ul style="list-style-type: none"> <li>• Discard the received data.</li> <li>• Use the previously received normal data for processing (servo is in alarm status).</li> <li>• Return Byte 1 of response as FFh.</li> <li>• RTEX communication keeps RUNNING status. <ul style="list-style-type: none"> <li>▪ Because the communication continues, if the normal reception is possible after occurrence of alarm, commands such as alarm clear can be received.</li> </ul> </li> </ul>
Action	<ul style="list-style-type: none"> <li>• Check the communication cable for excessive noises.</li> <li>• Check the communication cable for length, layout arrangement, and connections.</li> <li>• Check that the communication cable is category 5-e or better shielded twisted pair cable (STPC) specified by TIA/EIA-568.</li> <li>• Replace the cable with a new one as necessary.</li> <li>• Attach the ferrite core to the communication cable.</li> <li>• Replace the servo driver as necessary.</li> </ul>
Alarm clear attribute	<ul style="list-style-type: none"> <li>• Can be cleared.</li> </ul>
Display on COM LED	<ul style="list-style-type: none"> <li>• Flashing in red</li> </ul>

## 8-1-4 RTEX time out error protection (Err. 84.0)

This alarm will occur when communication data has not been received, and MNM1221 has not output the reception interrupt (missing reception) process start signal for predetermined period.

Cause	<ul style="list-style-type: none"> <li>• Communication data has not been received, and MNM1221 has not output the reception interrupt (missing reception) process start signal for predetermined period.</li> </ul>
Detecting timing	<ul style="list-style-type: none"> <li>• When RTEX communication status is RUNNING.</li> <li>• When synchronization between the communication and servo is established.</li> <li>• When received data is read at the communication cycle.</li> </ul>
Internal process upon detecting error	<ul style="list-style-type: none"> <li>• Use the previously received data for processing until an alarm is detected.</li> <li>• If an alarm is detected, RTEX communication state changes to INITIAL state.</li> <li>• Synchronization established between communication and servo is changed to asynchronous state. <ul style="list-style-type: none"> <li>▪ The communication blackout occurs so that the host controller should reestablish the communication.</li> </ul> </li> </ul>
Action	<ul style="list-style-type: none"> <li>• Check the communication cable for disconnection.</li> <li>• Check the preceding stage node whether it is ready for transmission. <ul style="list-style-type: none"> <li>▪ For checking procedure, refer to Section 8-3.</li> </ul> </li> <li>• Check the RTEX communication data transmission cycle of the host controller.</li> <li>• Check to see that the communication cycle set by Pr.7.20 RTEX communication cycle setting matches the transmission cycle of the host controller.</li> <li>• Check the communication cable for excessive noises.</li> <li>• Check the communication cable for length, layout arrangement, and connections.</li> <li>• Check that the communication cable is category 5-e or better shielded twisted pair cable (STPC) specified by TIA/EIA-568.</li> <li>• Replace the cable with a new one as necessary.</li> <li>• Attach the ferrite core to the communication cable.</li> <li>• Replace the servo driver as necessary.</li> </ul>
Alarm clear attribute	<ul style="list-style-type: none"> <li>• Can be cleared.</li> </ul>
Display on COM LED	<ul style="list-style-type: none"> <li>• Flashing in red</li> </ul>

## 8-1-5 RTEX synchronization and initialization error protection (Err. 84.3)

This alarm occurs when the initialization process fails to establish synchronization between the communication and servo driver.

Cause	<ul style="list-style-type: none"> <li>The initialization process fails to synchronize the communication and servo driver.</li> </ul>
Detecting timing	<ul style="list-style-type: none"> <li>On power up of servo driver control power.</li> <li>Upon restarting by the reset command.</li> </ul>
Internal process upon detecting error	<ul style="list-style-type: none"> <li>Fails to establish RTEX communication (aborts due to incomplete initialization)</li> <li>RTEX communication status is still in INITIAL condition (transition).</li> </ul>
Action	<ul style="list-style-type: none"> <li>Replace the servo driver if the cause is not removed after turning on control power.</li> </ul>
Alarm clear attribute	<ul style="list-style-type: none"> <li>Cannot be cleared.</li> </ul>
Display on COM LED	<ul style="list-style-type: none"> <li>Lighting in red</li> </ul>

## 8-1-6 RTEX communication cycle error protection (Err. 84.5)

This alarm occurs when the receive interrupt process start signal is output from MNM1221 at an irregular frequency, causing out of synchronization between communication and servo.

Cause	<ul style="list-style-type: none"> <li>The receive interrupt process start signal output from MNM1221 at an irregular cycle causes out-of-synchronization between communication and servo.</li> </ul>
Detecting timing	<ul style="list-style-type: none"> <li>When RTEX communication status is RUNNING.</li> <li>When synchronization between the communication and servo is established.</li> <li>Output of receive interrupt process start signal</li> </ul>
Internal process upon detecting error	<ul style="list-style-type: none"> <li>Use the previously received data for processing until an alarm is detected.</li> <li>If an alarm is detected, RTEX communication state changes to INITIAL state.</li> <li>Synchronization established between communication and servo is changed to asynchronous state. <ul style="list-style-type: none"> <li>The communication blackout occurs so that the host controller should reestablish the communication.</li> </ul> </li> </ul>
Action	<ul style="list-style-type: none"> <li>Check the RTEX communication data transmission cycle of the host controller.</li> <li>Check to see that the communication cycle set by Pr.7.20 RTEX communication cycle setting matches the transmission cycle of the host controller.</li> <li>Check the communication cable for excessive noises.</li> <li>Check the communication cable for length, layout arrangement, and connections.</li> <li>Check that the communication cable is category 5-e or better shielded twisted pair cable (STPC) specified by TIA/EIA-568.</li> <li>Replace the cable with a new one as necessary.</li> <li>Attach the ferrite core to the communication cable.</li> <li>Replace the servo driver as necessary.</li> </ul>
Alarm clear attribute	<ul style="list-style-type: none"> <li>Can be cleared.</li> </ul>
Display on COM LED	<ul style="list-style-type: none"> <li>Flashing in red</li> </ul>

## 8-1-7 RTEX cyclic data error protection 1/2 (Err. 86.0/Err. 86.1)

This alarm will occur, when data error in cyclic command area (C/R, MAC\_ID, cyclic command) occurs or when Sub\_Chk error continues in 32-byte mode for the predetermined period.

Cause	<ul style="list-style-type: none"> <li>Data error occurs in cyclic command area (C/R, MAC_ID, cyclic command) or Sub_Chk error continues in 32-byte mode for the predetermined period.</li> </ul>			
	Alarm code	Detected space		Cause
	Err. 86.0	Byte 0. bit 4–0	MAC-ID	Not fit with setting on rotary switch
		Byte 0. bit 7	C/R	Set at 1
		Byte 16. bit 7	Sub_Chk	Set at 0
Err. 86.1	Byte 1. bit 6–4	Cyclic command	Undefined	
Detecting timing	<ul style="list-style-type: none"> <li>When RTEX communication status is RUNNING.</li> <li>When synchronization between the communication and servo is established.</li> <li>When received data is read at the communication cycle.</li> </ul>			
Internal process upon detecting error	<ul style="list-style-type: none"> <li>Command error occurs while in alarm condition.</li> </ul>			
	Alarm code	Detected space		Error_Code
	Err. 86.0	Byte 0. bit 4–0	MAC-ID	0011h
		Byte 0. bit 7	C/R	0012h
		Byte 16. bit 7	Sub_Chk	
Err. 86.1	Byte 1. bit 6–4	Cyclic command	0021h	
<ul style="list-style-type: none"> <li>For details of command error, see Section 6-9-1.</li> <li>Discard the received data.</li> <li>Use the previously received normal data for processing (servo is in alarm status).</li> <li>RTEX communication keeps RUNNING status. <ul style="list-style-type: none"> <li>Because the communication continues, if the normal reception is possible after occurrence of alarm, commands such as alarm clear can be received.</li> </ul> </li> </ul>				
Action	<ul style="list-style-type: none"> <li>Check the data in the cyclic command field (Detected space in the table above).</li> <li>Check the process in the host controller</li> </ul>			
Alarm clear attribute	<ul style="list-style-type: none"> <li>Can be cleared.</li> </ul>			
Display on COM LED	<ul style="list-style-type: none"> <li>Flashing in red</li> </ul>			

## 8-1-8 RTEX\_Update\_Counter error protection (Err86.2)

This alarm will occur when Update\_Counter is not renewed correctly because errors have been accumulated more than set number for Pr.7.38 (RTEX\_Update\_Counter error protection).

When Pr7.38 is 0 or 1, this alarm is invalid.

This alarm is to detect conflict in command renewal cycle between an upper device and the amplifier. Be careful, detection may not be performed correctly if the communication cycles are not synchronized.

Cause	<ul style="list-style-type: none"> <li>Update_Counter is not renewed correctly because errors have been accumulated more than set number for Pr.7.38 (RTEX_Update_Counter error protection).</li> </ul>
Detecting timing	<ul style="list-style-type: none"> <li>RTEX communication is in RUNNING state.</li> <li>Sync establishment between communication and servo is in transient condition.</li> <li>At reading received data of each command renewal cycle.</li> </ul>
Internal process upon detecting error	<ul style="list-style-type: none"> <li>Received data are taken as they are.</li> <li>RTEX communication state keeps RUNNING state.</li> <li>Sync establishment condition between communication and servo is continued.</li> </ul>
Action	<ul style="list-style-type: none"> <li>Check if there is any problem in frequency setting in upper device side and in amplifier side.</li> <li>When Update_Counter is not used with ratio of communication frequency and command renewal frequency being 1 : 1, this alarm is made invalid.</li> </ul>
Alarm clear attribute	<ul style="list-style-type: none"> <li>Can not be cleared.</li> </ul>
Display on COM LED	<ul style="list-style-type: none"> <li>Lights in red</li> </ul>

## 8-1-9 RTEX interaxis sync establishment error protection (Err90.2)

This alarm will occur when communication error occurs in the full-sync mode and in sync establishment transient condition or when the communication is interrupted.

Cause	<ul style="list-style-type: none"> <li>• Communication error occurs in full-sync mode and in sync establishment transient condition or the communication is interrupted.</li> </ul>
Detecting timing	<ul style="list-style-type: none"> <li>• RTEX communication is in RUNNING state.</li> <li>• Sync establishment between communication and servo is in transient condition.</li> </ul>
Internal process upon detecting error	<ul style="list-style-type: none"> <li>• After detection of alarm, RTEX communication shifts to INITIAL state.</li> <li>• Sync establishment condition between communication and servo is undefined.</li> </ul>
Action	<ul style="list-style-type: none"> <li>• Take the same measures as for Err83.0 or Err84.0.</li> </ul>
Alarm clear attribute	<ul style="list-style-type: none"> <li>• Can be cleared.</li> </ul>
Display on COM LED	<ul style="list-style-type: none"> <li>• Flashing in red</li> </ul>



## 8-1-10 RTEX command error protection (Err91.1)

This error will occur when the cyclic command (Byte 1, bits 6–4) is defined but not correctly received.

Cause	<ul style="list-style-type: none"> <li>• Mismatched combination of communication cycle, semi-closed/full-closed, 16/32-byte mode and control mode.</li> <li>• The control mode switching interval is shorter than 2 ms.</li> <li>• Control mode is switched during profile position latch positioning/profile homing operation (Type_Code = 12h, 13h, 31h, 32h, 33h).</li> <li>• Control mode is switched during processing of non-cyclic command (Busy = 1).</li> <li>• During operation of profile position latch positioning/profile homing (Type_Code = 12h, 13h, 31h, 32h, 33h), the homing command (□4h) is executed.</li> <li>• During operation of profile positioning/profile continuous movement (Type_Code = 10h, 11h, 20h), the initialization mode (Type_Code = 1□h, 31h) of the homing command (□4h) is executed.</li> <li>• During operation with profile position control (PP), Type_Code is changed.</li> <li>• Run the home return command (□4h) Type_Code=1□h/2□h during the velocity control (CV)/torque control (CT)</li> </ul>
Detecting timing	<ul style="list-style-type: none"> <li>• When RTEX communication status is RUNNING.</li> <li>• When synchronization between the communication and servo is established.</li> <li>• When received data is read at the communication cycle.</li> </ul>
Internal process upon detecting error	<ul style="list-style-type: none"> <li>• The command error occurs upon occurrence of the alarm. <ul style="list-style-type: none"> <li>▪ For details of command error, see Section 6-10-1.</li> </ul> </li> <li>• RTEX communication keeps RUNNING status.</li> </ul>
Action	<ul style="list-style-type: none"> <li>• Check the process of the host controller. <ul style="list-style-type: none"> <li>▪ When changing to another control mode after selecting the current mode, wait at least for 2 ms.</li> <li>▪ Check correspondence relation between the executive function and control mode.</li> </ul> </li> </ul>
Alarm clear attribute	<ul style="list-style-type: none"> <li>• Can be cleared.</li> </ul>
Display on COM LED	<ul style="list-style-type: none"> <li>• Flashing in red</li> </ul>

## 8-1-11 RTEX hardware error protection 1/2/3 (Err. 98.1/Err. 98.2/Err. 98.3)

This alarm occurs when an error occurs in RTEX communication circuit.

Cause	<ul style="list-style-type: none"> <li>An error occurs on RTEX communication circuit.</li> </ul>
Detecting timing	<ul style="list-style-type: none"> <li>On power up of servo driver control power.</li> <li>Upon restarting by the reset command.</li> </ul>
Internal process upon detecting error	<ul style="list-style-type: none"> <li>RTEX communication cannot be established due to incomplete initialization.</li> <li>RTEX communication status is still in INITIAL condition (transition).</li> </ul>
Action	<ul style="list-style-type: none"> <li>Replace the servo driver if the cause is not removed after turning on control power.</li> </ul>
Alarm clear attribute	<ul style="list-style-type: none"> <li>Cannot be cleared.</li> </ul>
Display on COM LED	<ul style="list-style-type: none"> <li>Lighting in red</li> </ul>

## 8-2 RTEX communication warnings

Warning code (decimal)	Designation
C0h	RTEX continuous communication error warning
C1h	RTEX accumulated communication error warning
C2h	RTEX Update_Counter error warning

## 8-2-1 RTEX continuous communication error warning (WngC0h)

This warning will occur when the No. of continuously detected reading errors (CRC errors) of the data delivered to the local node reaches the setting value of Pr.7.26 RTEX successive communication error warning setting. The detecting timing and corrective action are basically the same as those for Err. 83.0 RTEX continuous communication error.

When Pr.7.26 is 0 or when bit 9 of Pr.6.38 Attribute C is 0, this warning is disabled.

Cause	<ul style="list-style-type: none"> <li>The No. of detected continuous reading errors (CRC errors) of the data delivered to the local node reaches the setting value of Pr.7.26 RTEX successive communication error warning setting.</li> </ul>
Detecting timing	<ul style="list-style-type: none"> <li>When RTEX communication status is RUNNING.</li> <li>When received data is read at the communication cycle.</li> </ul>
Internal process upon detecting error	<ul style="list-style-type: none"> <li>Discard the received data.</li> <li>Use the previously received normal data for processing.</li> <li>Return Byte 1 of response as FFh.</li> <li>RTEX communication keeps RUNNING status.</li> <li>Synchronization between communication and servo is kept established. <ul style="list-style-type: none"> <li>Because the communication continues, if the normal reception is possible after occurrence of warning, commands such as alarm clear can be received.</li> </ul> </li> </ul>
Action	<ul style="list-style-type: none"> <li>Check the communication cable for excessive noises.</li> <li>Check the communication cable for length, layout arrangement, and connections.</li> <li>Check that the communication cable is category 5-e or better shielded twisted pair cable (STPC) specified by TIA/EIA-568.</li> <li>Replace the cable with a new one as necessary.</li> <li>Attach the ferrite core to the communication cable.</li> <li>Replace the servo driver as necessary.</li> </ul>
Warning clearing procedure after removal of cause	<ul style="list-style-type: none"> <li>Disable this warning and then execute alarm clear.</li> <li>Execute the power reset or reset command to reboot the system.</li> </ul>

## 8-2-2 RTEX accumulated communication error warning (WngC1h)

This warning will occur when the No. of detected accumulated reading errors (CRC errors) of the data delivered to the local node reaches the setting value of Pr.7.27 RTEX accumulated communication error warning setting. The detecting timing and corrective action are basically the same as those for Err. 83.0 RTEX continuous communication error.

When Pr.7.27 is 0 or when bit 10 of Pr.6.38 Attribute C is 0, this warning is disabled.

Cause	<ul style="list-style-type: none"> <li>The No. of detected accumulated reading errors (CRC errors) of the data delivered to the local node reaches the setting value of Pr.7.27 RTEX accumulated communication error warning setting.</li> </ul>
Detecting timing	<ul style="list-style-type: none"> <li>When RTEX communication status is RUNNING.</li> <li>When received data is read at the communication cycle.</li> </ul>
Internal process upon detecting error	<ul style="list-style-type: none"> <li>Discard the received data.</li> <li>Use the previously received normal data for processing.</li> <li>Return Byte 1 of response as FFh.</li> <li>RTEX communication keeps RUNNING status.</li> <li>Synchronization between communication and servo is kept established. <ul style="list-style-type: none"> <li>Because the communication continues, if the normal reception is possible after occurrence of warning, commands such as alarm clear can be received.</li> </ul> </li> </ul>
Action	<ul style="list-style-type: none"> <li>Check the communication cable for excessive noises.</li> <li>Check the communication cable for length, layout arrangement, and connections.</li> <li>Check that the communication cable is category 5-e or better shielded twisted pair cable (STPC) specified by TIA/EIA-568.</li> <li>Replace the cable with a new one as necessary.</li> <li>Attach the ferrite core to the communication cable.</li> <li>Replace the servo driver as necessary.</li> </ul>
Warning clearing procedure after removal of cause	<ul style="list-style-type: none"> <li>Disable this warning and then execute alarm clear.</li> <li>Execute alarm clear command or the power reset or reset command to reboot the system.</li> </ul>

## 8-2-3 RTEX Update\_Counter error warning (WngC2h)

This warning will occur when the total No. of updates of Update\_Counter does not reach the setting of Pr.7.28 RTEX\_Update\_Counter error warning setting.

When the setting of Pr.7.28 is 0 or 1, or when bit 11 of Pr.6.38 Attribute C is 0, this warning is invalid.

This warning indicates that updating cycle of the host controller and that of the servo driver are different with each other. Mismatched communication cycles will cause detection error.

Cause	<ul style="list-style-type: none"> <li>Total number of updates of Update_Counter does not reach the setting of Pr.7.28 RTEX_Update_Counter error warning setting.</li> </ul>
Detecting timing	<ul style="list-style-type: none"> <li>When RTEX communication status is RUNNING.</li> <li>When synchronization between the communication and servo is established.</li> <li>When received data is read at the command update cycle.</li> </ul>
Internal process upon detecting error	<ul style="list-style-type: none"> <li>Capture the received data as it is.</li> <li>RTEX communication keeps RUNNING status.</li> <li>Synchronization between communication and servo is kept established. <ul style="list-style-type: none"> <li>Because the communication continues, if the normal reception is possible after occurrence of warning, commands such as alarm clear can be received.</li> </ul> </li> </ul>
Action	<ul style="list-style-type: none"> <li>Check to see that the host controller and driver are normally setting cycles.</li> <li>When the communication cycle to command updating cycle ratio is 1:1 and Update_Counter is not used, this warning is disabled.</li> </ul>
Warning clearing procedure after removal of cause	<ul style="list-style-type: none"> <li>Disable this warning and execute alarm clear.</li> <li>Execute alarm clear command or the power reset or reset command to reboot the system.</li> </ul>

### 8-3 Locating disconnection point of network cable

With power supplied to all nodes, check the network status LEDs, "LINK". If an LED is not lighting, check the network cable connected to the receiving connector (RX) of the servo driver having the unlit LED.

When checking on/off status of the LED, test the electrical connection regardless of condition and performance of RTEX communication.

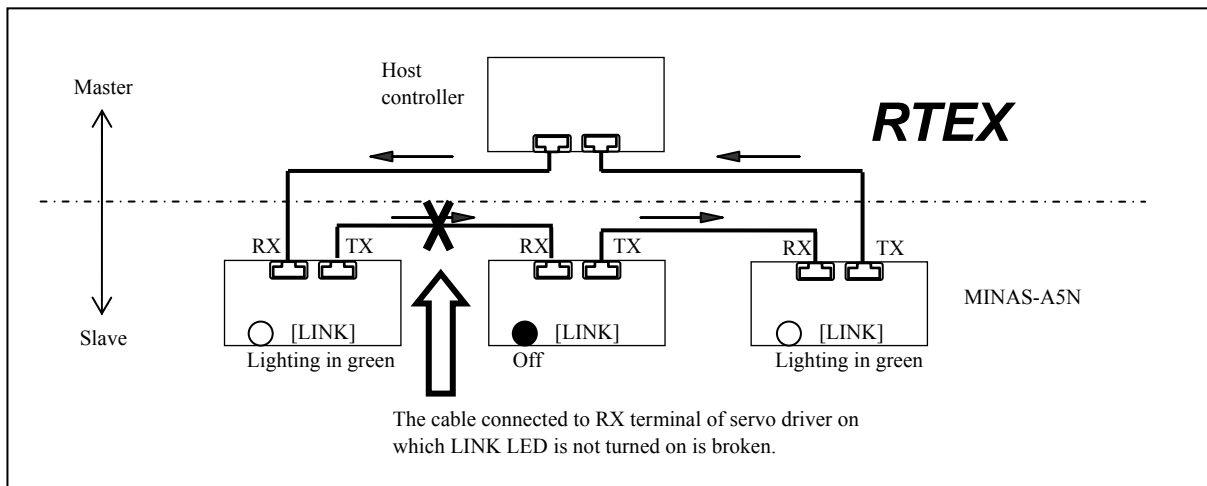
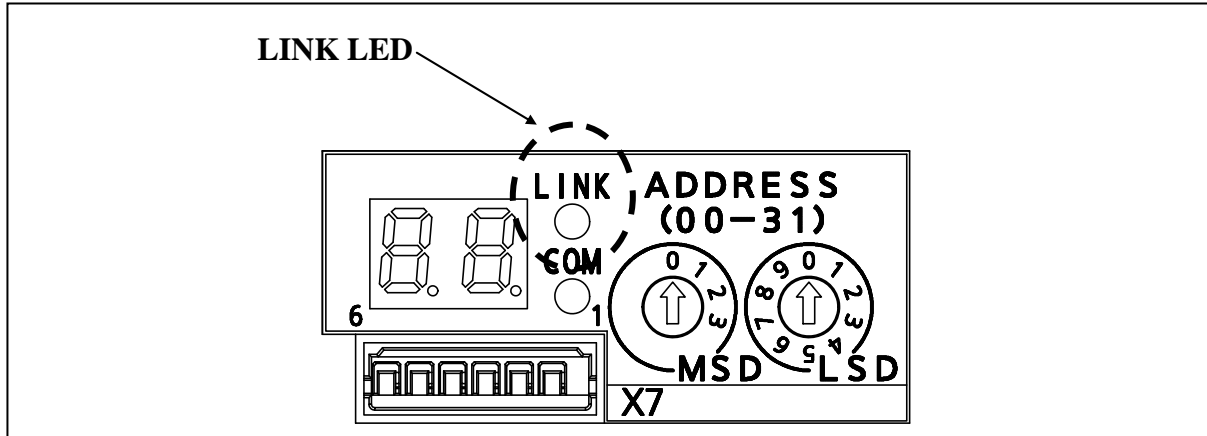

When the network cable connected to the receiving side breaks, Err. 84.0 RTEX communication time out error occurs.

When LINK LED that has been lighting in green is turned off, the possible cause is: disconnection or loose connection of cable, or resetting (power shutdown or reset command) of the node connected to the preceding stage.

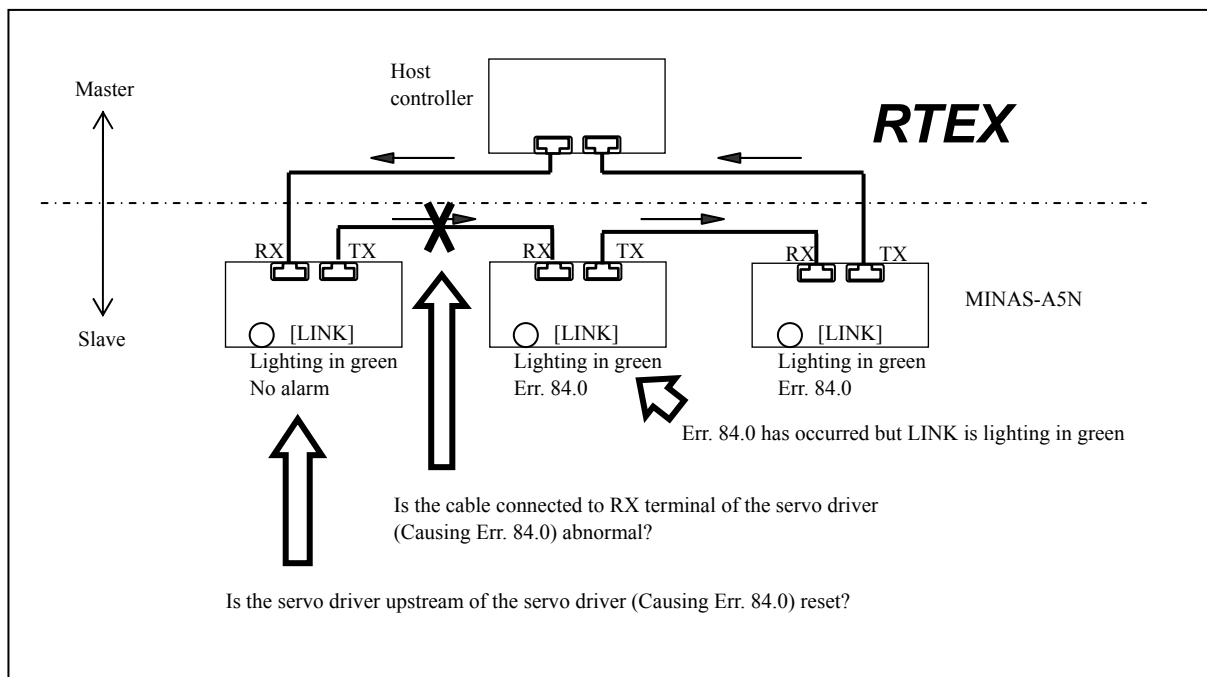

**Note:** When the master detects time out, send servo off command to all servos without initializing the communication to shut down the servos connected upstream of disconnection point.  
If the communication is initialized, all servos will cause Err. 84.0 Communication timeout error, making it difficult to locate the disconnected section.